

2.5

Annex

SP Energy Networks 2015–2023 Business Plan

Sample scheme papers

SP Energy Networks

June 2013

SP Energy Networks
2015-2023 Business Plan
Sample Scheme Papers Annex

Preparing to Deliver Our Investments

This annex to our 2015-2023 Business Plan provides a range of sample scheme papers that demonstrate the extent of our preparations for the delivery of our investment plans during ED1.

The rigorous processes we have used to prepare our plans for business readiness are detailed in our 2015-23 Business Plan, Chapter 4 — Process of creating our business plan. We also provide more detail within Chapter 10 – Business Readiness.

In brief, our preparations include:

- *comprehensive on-site surveys*
- *detailed engineering studies, considering alternative solutions*
- *project and outage planning, including coordination with third parties*
- *a comprehensive review of our purchasing strategies*

We have significantly increased the level of detail in our early deliverability plans for the ED1 period. We have shared our plans with our key suppliers and the contractor community through dedicated events, one-to-one meetings and small group sessions. We have examined the critical aspects of our business plan and established a robust business readiness programme.

Within this annex we provide some examples of both load and non-load projects we plan to undertake within the ED1 period.

Sample Scheme Papers Annex

Municipality	Caergeiliog, Anglesey	Country: Wales	
Title	Anglesey Reinforcement	Voltage	132kV & 33 kV
Description	<p>Reinforce the 33kV network on Anglesey, to solve thermal and voltage constraints and increase reliability during outages whilst accommodating current demand and existing high levels of embedded generation on the island.</p> <p>The proposal will also facilitate future demand and generation connections in line with the Company's Licence obligations.</p>		
Due to complete in	2023		

SCOPE:

- Extend NGET substation at Wylfa with a new 132kV feeder bay.
- Re-build the existing Wylfa to Caergeiliog single circuit 132kV overhead line with double circuit tower line (~16km).
- Install a new Grid Transformer at Caergeiliog 132/33kV – 60 MVA.
- Extend Caergeiliog 33kV switchboard with a new 33kV grid transformer bay.

MAP :



DESCRIPTION :

The network under consideration is the Amlwch, Caergeiliog 33kV demand group on the isle of Anglesey consisting of two aging 45MVA Grid Transformers fed at 132kV from Wylfa Substation. There are two 33kV circuits that run under the Menai straits and interconnect the group with 33kV system on the mainland.

The island has a winter maximum demand of 69MVA and it is anticipated that this demand will increase significantly over the next 10 years due to various regeneration and development projects by the Welsh Government. There is also 35MW of existing wind generation and another 40MW of solar and tidal generation from recently accepted formal offers to be connected over the next several years. It is anticipated that this growth in load and generation on the island will continue to increase significantly.

The isle of Anglesey is currently operating at thermal and voltage limits and consequently it is becoming problematic to accommodate any further generation or demand.

The investment proposed has been selected from four alternative solutions and will increase both thermal and voltage capacity to a level that will provide headroom for anticipated generation/load growth in the area including SPM Best View Scenario for capacity based on Work Stream 3 analysis and stakeholder engagement with the local planning authority and Horizon Nuclear (the company formed to deliver the re-planting of the nuclear power station at Wylfa). The proposal will create a robust independent group of three grid transformers increasing thermal capacity to meet further demand and generation needs.

SINGLE LINE DIAGRAMS : (132kV and 33 kV)

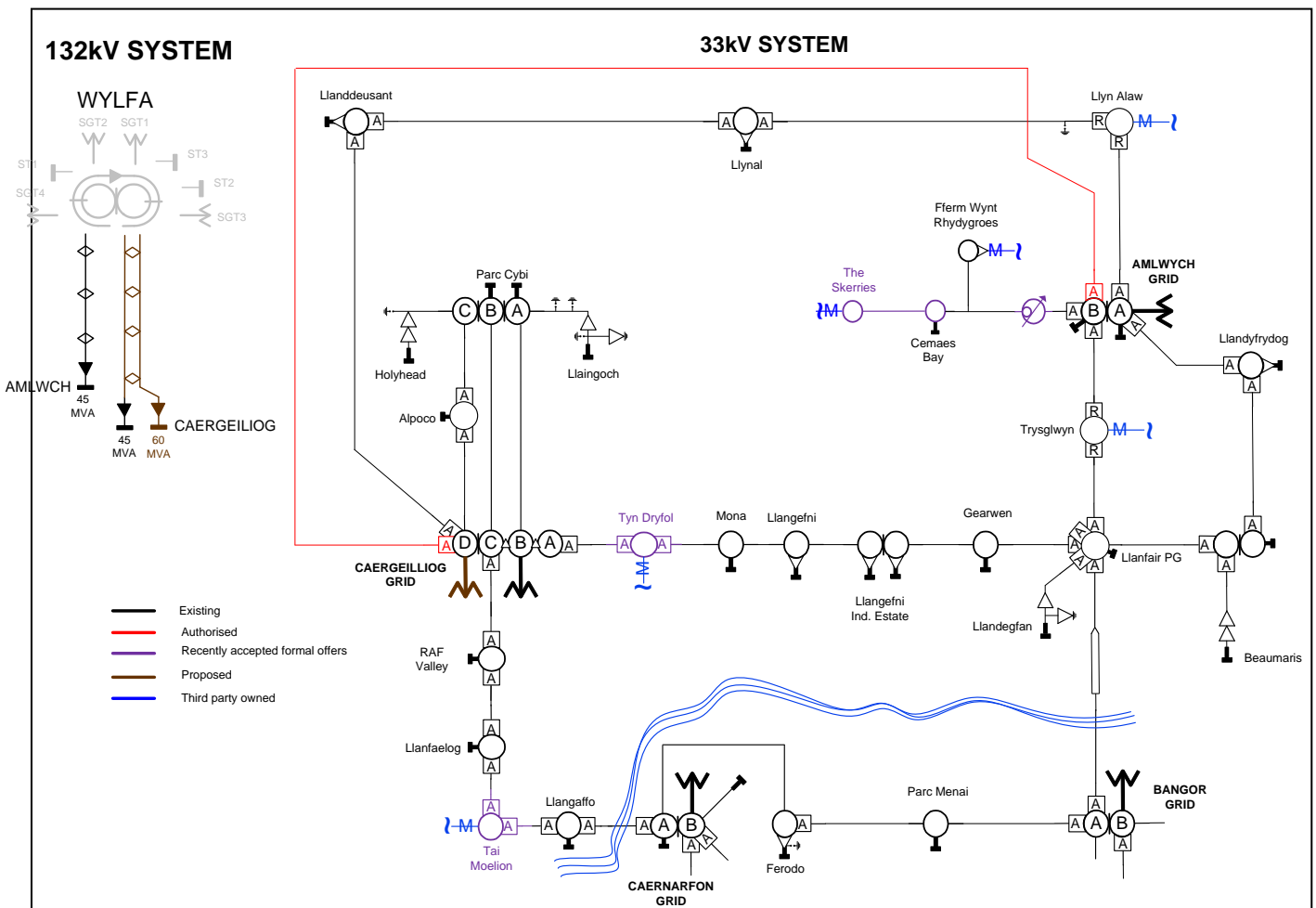

Sample Scheme Papers Annex

Municipality	Crewe, Cheshire, Cheshire East	Country:	England
Title	Crewe Reinforcement	Voltage	132 kV
Description	Strategic investment in a potential smart 132kV network solution in Crewe in order to defer significant conventional reinforcement required to increase supply security and facilitate future load growth in the local area		
Due to complete in	2020		

SCOPE

- To establish the feasibility of a smart solution to install a 132kV Phase Shift Transformer (PST) between the Cellarhead and Fiddlers Ferry/Carrington 132kV groups
- If feasible to install a 132kV PST and associated 132kV Bays at Crewe Grid Substation
- Undertake fault level mitigation works in 33kV demand groups affected by the PST

MAP

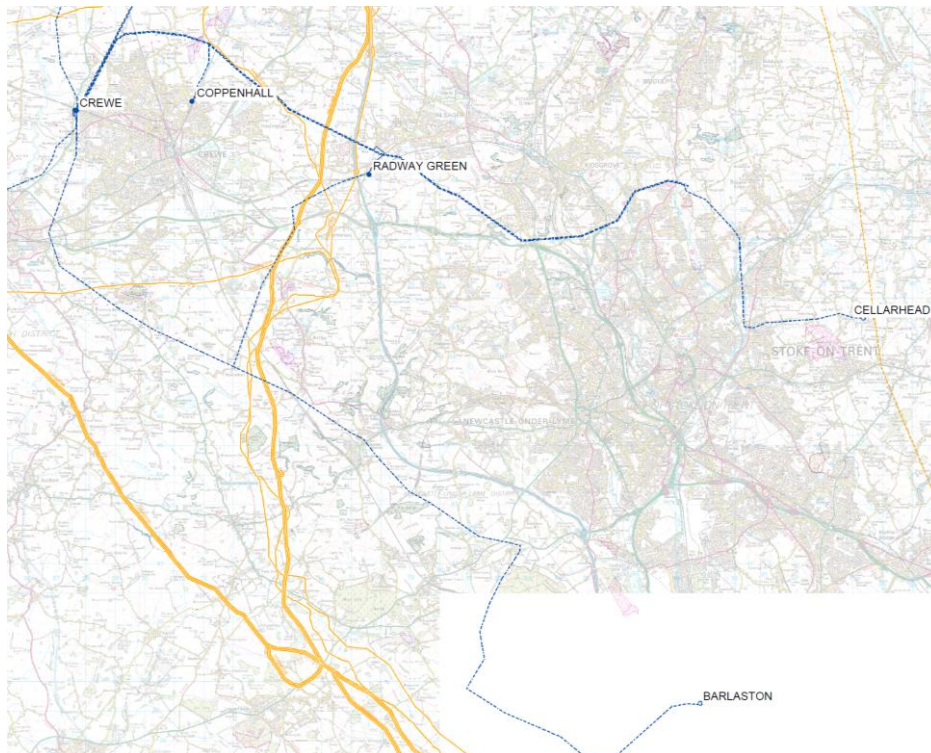

DESCRIPTION

The 132kV system in Crewe and the surrounding area is supplied via three 132kV circuits. One of the circuits is fed from Cellarhead GSP that are owned and operated by National Grid and the other two circuits are fed from metered supply points at Whitfield and Barleston substations that are owned and operated by the adjacent DNO Western Power Distribution (WPD).

WPD have indicated that the maximum demand they can provide from Whitefield is 50MVA under n-1 conditions associated with their 132kV network and may be required to disconnect the Whitefield circuit if SPM demand cannot be constrained to a level that does not put their system at risk. Studies indicate SPM cannot constrain power flows on this circuit to less than 50MVA and discussions are ongoing with WPD to identify and assess options to resolve this issue.

Excluding the potential constraint on the Whitefield circuit the most onerous condition is an n-2 outage of the Cellarhead/Whitfield circuits (both circuits on the same tower line). Studies indicate an n-2 outage of these circuits during summer maintenance demand would cause power flows that significantly exceed the circuit rating and would make it necessary to disconnect significant levels of demand.

In order to comply with section 9 of the Electricity Act and Condition 21 of our license obligation “to develop and maintain an efficient, coordinated and economical system for the distribution of electricity” an enduring design solution is required in order to satisfy the existing demand requirements and accommodate future load growth.

If detailed assessments indicate this option is technically viable the PST will potentially meet this requirement, increasing both thermal and voltage capacity to a level that will also provide headroom for anticipated load growth in the area including SPM Best View Scenario for capacity based on WS3 analysis.

The connection of the PST would increase 33kV fault levels requiring switchgear to be replaced and therefore a provisional sum of £2m has been included within the overall estimate.

The installation of a PST at Crewe would connect three GSPs and part of the interconnection would be via a 132kV network that is owned and operated by WPD. Therefore, detailed analysis of the SPM, WPD and National Grid system will be required to assess the viability of this solution.

The alternative conventional options involve significant 132kV overhead lines to be constructed at a estimated cost of over £20m and with the risk of a significant fluctuation in cost if the ratio of cable to overhead line increases following the planning/consenting of the circuit.

Given that there is a level of uncertainty associated with installing a PST at Crewe it is proposed to also progress some of the pre-engineering works associated with the conventional solution to mitigate some of the risk of the PST being found to be unviable following detailed analysis and liaison with National Grid/WPD.

Sample Scheme Papers Annex

SINGLE LINE DIAGRAM (132 kV)

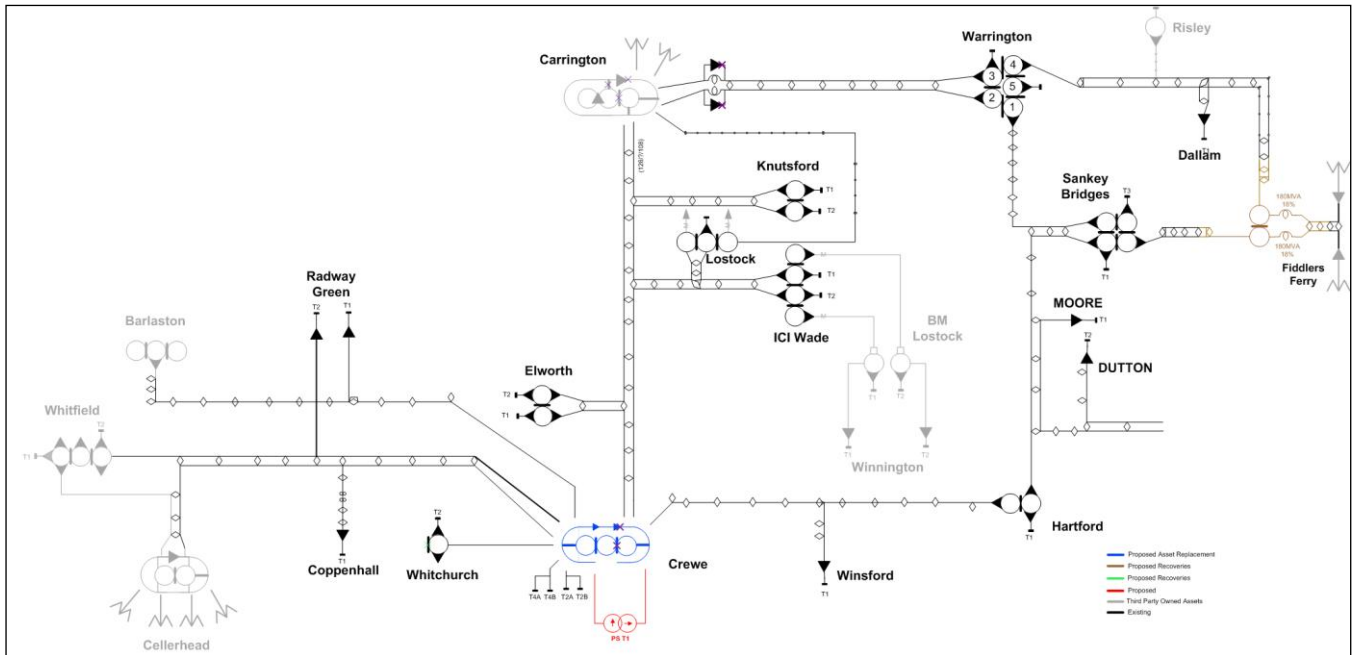

Sample Scheme Papers Annex

Municipality	Moodiesburn, North Lanarkshire	Country: Scotland	
Title	Gartferry Road Reinforcement	Voltage	33 kV
Description	Equip Gartferry Road substation to allow demand to be transferred between Cumbernauld and Easterhouse GSPs		
Due to complete in	2021		

SCOPE:

- Build a new 33kV double circuit from Easterhouse GSP to Gartferry Road (~6Km)
- Equip Gartferry Road Substation with new 33kV breakers and 2x12/24 transformers
- Install 2 new 33kV feeder breakers at Easterhouse substation

MAP:

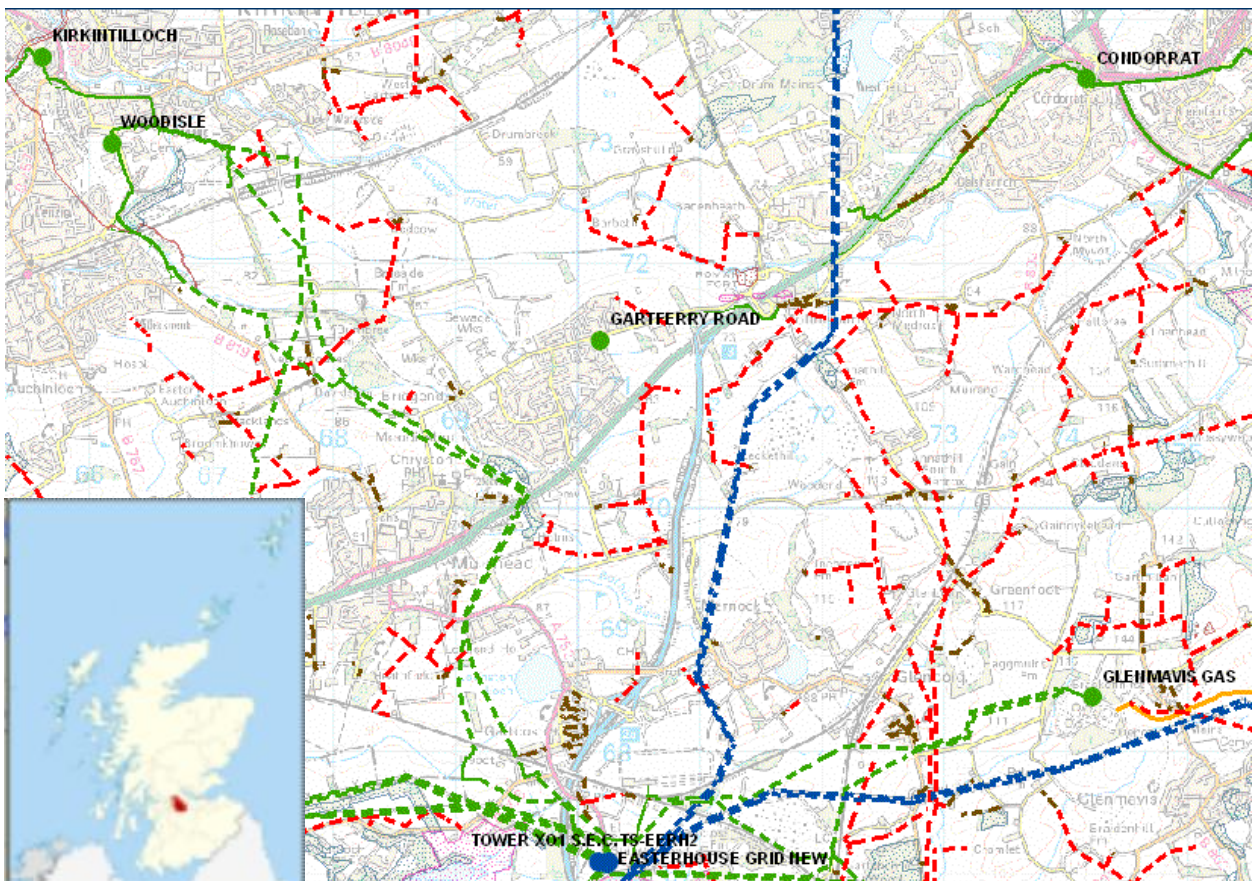

Sample Scheme Papers Annex

DESCRIPTION:

Gartferry Road substation is located in the Moodiesburn area of North Lanarkshire, 8 miles north-east from the Glasgow city centre, adjacent to the newly upgraded M80 motorway and close to the industrial park at nearby Mollinsburn.

Gartferry Road is currently laid out in the form of a primary substation minus the 33/11kV transformers. The 11kV switchboard is fed via two dedicated 11kV circuits (33kV circuits running at 11kV) from Condorrat 33/11kV. A major customer (Devro) is also supplied from this site, and had been subject to power quality issues due to the current network configuration.

It is proposed to equip the substation at Gartferry Road with 2x 12/24MVA transformers and provide a 33kV supply from Easterhouse GSP. This will require two new 33kV feeder breakers to be installed at Easterhouse and two new 33kV UG cables to be laid to Gartferry Road with an approximate route length of 6Km.

The existing 11kv circuits will be retained to provide interconnection between Cumbernauld and Easterhouse GSPs, allowing demand to be transferred in case of outages.

SINGLE LINE DIAGRAM: (33 kV)

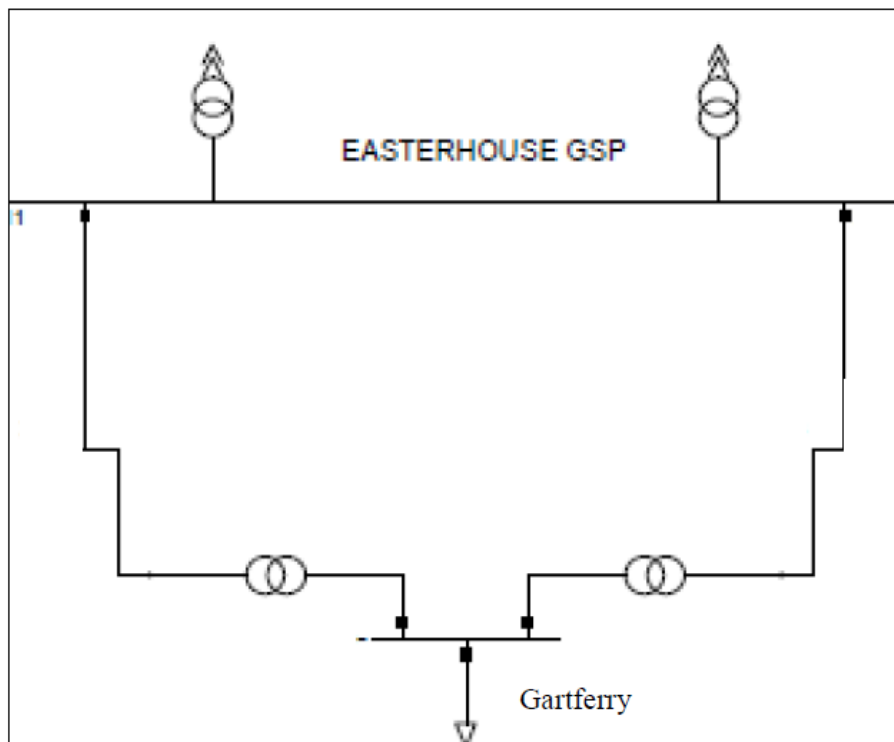

Sample Scheme Papers Annex

Municipality	District of Govan, Glasgow	Country:	Scotland
Title	Govan 6.6kV Upgrade	Voltage	6.6 kV
Description	Upgrade Govan 6.6kV network to 11kV		
Due to complete in	2020		

SCOPE:

- Convert the existing 6.6kV/LV substations to dual ratio (6.6kV-11kV)
- Replace the 33/6.6kV Transformers at Admiral Street, St. Andrews Cross, Elizabeth Street and Helen Street
- Migrate 6.6kV network to 11kV Operation
- “Future proof” / Smart enable the new 11kV network

MAP:

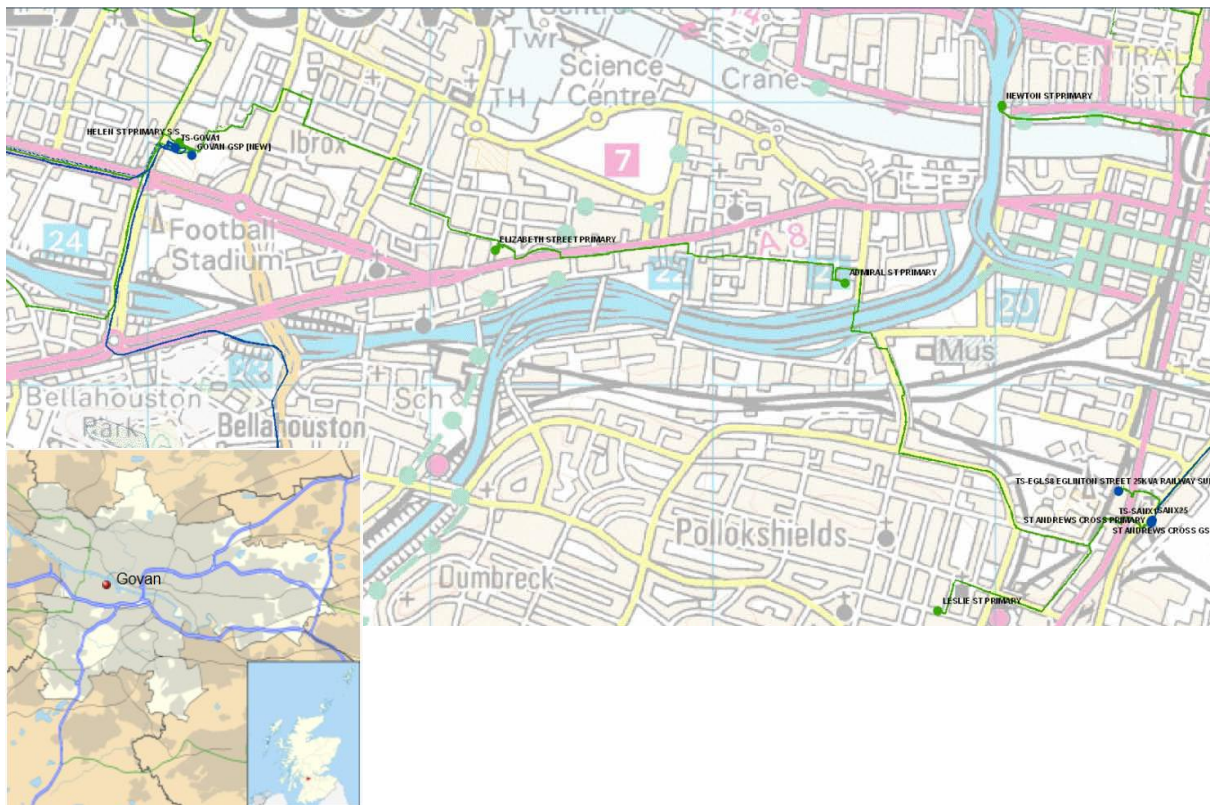

Sample Scheme Papers Annex

DESCRIPTION:

SPD operates the distribution system with standard voltage levels of 33kV, 11kV and 400/230V. Nonetheless, there are some legacy island networks which operate at non-standard voltages, such as 22kV and 6.6kV. Some customers take supply from that non-standard voltages, and this situation will remain until their own requirements trigger an application for change.

The district of Govan, in the southwest of Glasgow, has two 6.6kV Islands: Admiral Street/St. Andrews Cross and Elizabeth Street/Helen Street, with little interconnection between them. These non-standard voltage networks result in constrained system capacity, and incremental costs for dual ratio equipment. The diminishing population of 6.6kV plant also presents risks from the perspective of fault repairs and spares availability, so the proposed solution is to upgrade these networks to the standardized voltage of 11kV, creating additional capacity for the connection of load and generation.

Works will be completed in two phases : Admiral Street/St. Andrews Cross 6.6kV network followed by Elizabeth Street / Helen Street 6.6kV network.

This project provides a significant opportunity to 'smart enable' the new switchgear units and associated substation and field equipment to provide the foundation of future additional smart functionality. It is planned to achieve this by installing:

- IEC 61580 Complaint Substation Devices (including protection devices);
- Dynamic Network Protection at 11kV;
- RMUs Fitted with Actuators;
- Link boxes fitted with remote control
- Communications to and from devices

SINGLE LINE DIAGRAM: (6.6 kV)

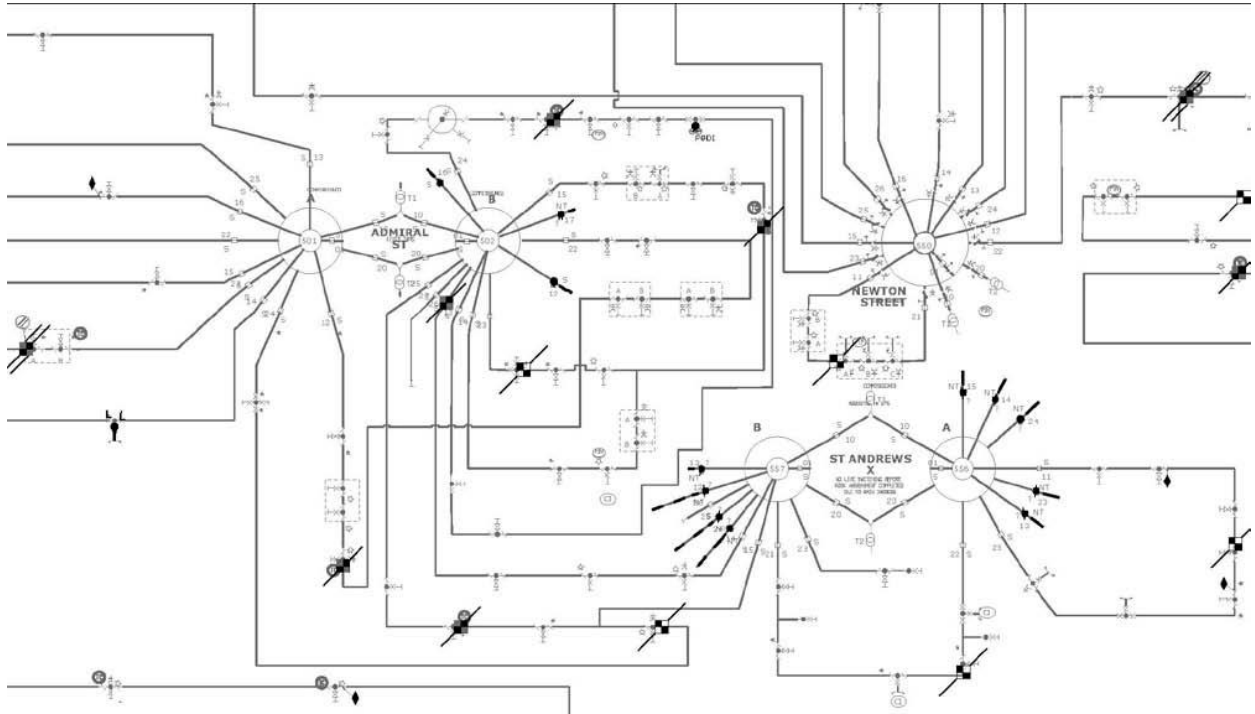

Sample Scheme Papers Annex

Municipality	Portobello, Edinburgh	Country:	Scotland
Title	Portobello fault level resolution	Voltage	11 kV
Description	Reconfigure Portobello substation, establishing two standard separate primary substations to reduce fault level at 11kV network		
Due to complete in	2017		

SCOPE:

- Reconfigure Portobello Substation, splitting existing substation into two standard independent primary substations
- Each Substation with two 33/11 kV transformers of 12/24MVA capacity

MAP:



DESCRIPTION:

Portobello Substation, located 5 km to the east of city centre of Edinburgh, is equipped with three 33/11kV transformers (12/24MVA units) with a firm capacity of 48MVA, feeding three separate 11kV switchboards in an un-conventional interconnected arrangement.

The 11kV network operates as rings around a single switchboard as well as interconnectors between switchboards. Due to this, the existing fault levels are operating in excess of the switchgear rating. Currently access restrictions are in place to mitigate the risks posed by operating in this manner.

It is not possible to reduce the fault level by operating with a transformer on open standby due to the configuration of the 11kV primary switchboards and the high demand served by this substation.

The proposed solution to overcome the limitations posed by the existing network arrangements is to reconfigure existing system, establishing two standard separate primary substations, which will thereby reduce the fault levels at this site.

Each of the substations will be equipped with two 33/11kV transformers with a capacity of 12/24MVA each.

SINGLE LINE DIAGRAM

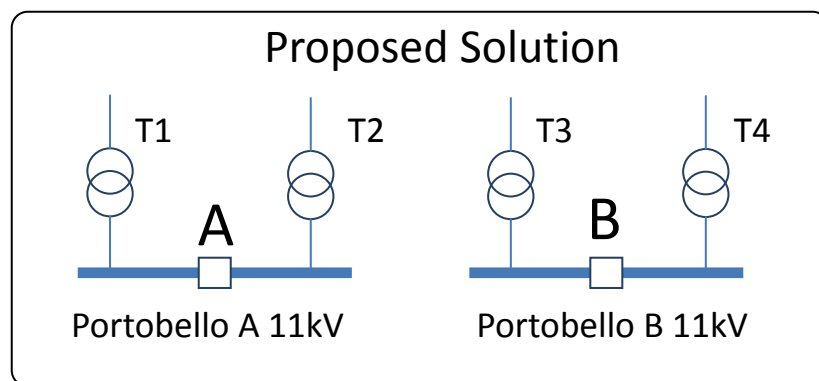
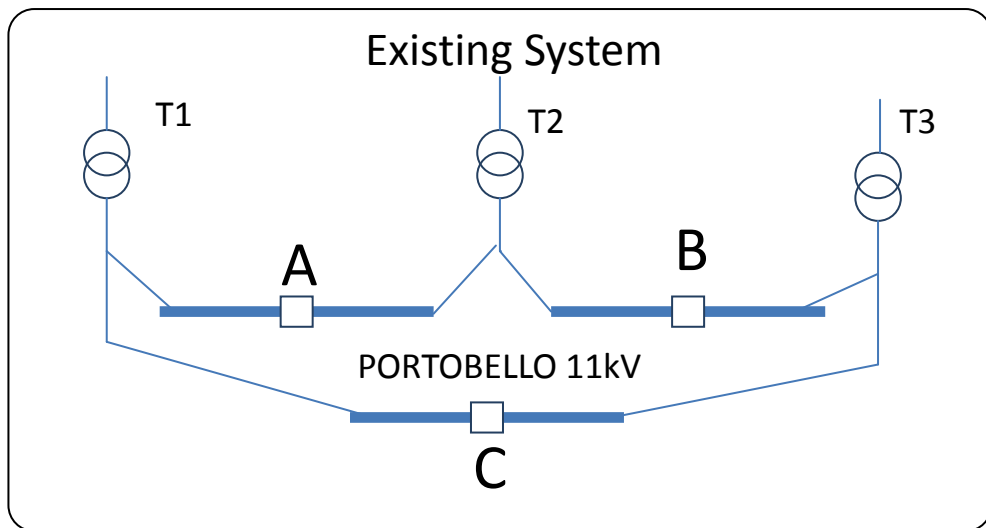

Sample Scheme Papers Annex

Municipality	Innerleithan area, Scottish Borders	Country:	Scotland
Title	Yair Bridge Voltage Uprating	Voltage	6.6kV and 22 kV
Description	Implement a phased migration of the two 6kV islands to a standard 11kV network and develop proposals for migration of the 22kV network in the ED2 period.		
Due to complete in	2021	Due to complete in	2021

SCOPE:

- Migration of the existing 6.6kV network to 11kV by re-equipping the primary substation at Innerleithan with dual ratio 22kV - 11/6kV equipment.
- Upgrading and re-equipping the 6.6kV network to facilitate 11kV operation and interim running arrangements.

MAP:

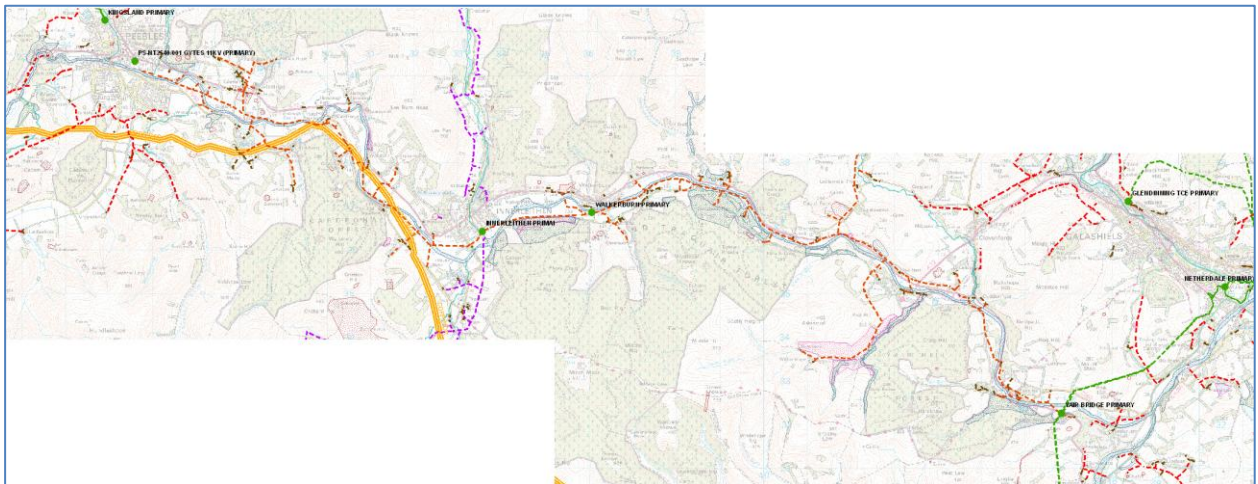

Figure 1: Geographic Area

Sample Scheme Papers Annex

DESCRIPTION :

In order that the 6kV system is migrated to 11kV, the primary substation at Innerleithan will be migrated to dual ratio 22kV - 11/6kV equipment. The 6kV system and equipment will be upgraded and replanted to facilitate operation prior to conversion to a final changeover.

The 22kV system is extensive in geographic terms and therefore migration to 11kV may require the creation of additional primary substations to maintain voltage regulation. Similarly, migrating to a 33kV system with 33kV/LV transformation at customer connection points is unlikely to be economic. Therefore, the 22kV system will be retained at this point in time with any significant refurbishment work taking cognisance of the possible future requirements to uprate operating voltage. The network will be assessed within the ED1 period and optimal solutions developed (where appropriate) for submission and construction within ED2.

As this scheme provides a significant opportunity to review the existing distribution network in the area, the opportunity will be taken to 'smart enable' the new switchgear units and associated substation and field equipment which will be installed as part of the 11kV upgrade to provide the foundation of future additional smart functionality.

It is planned to achieve this by installing

- IEC 61580 Complaint Substation Devices (including protection devices);
- Dynamic Network Protection at 11kV;
- RMUs Fitted with Actuators;
- Link boxes fitted with remote control and
- Communications to and from devices

SINGLE LINE DIAGRAM

Figure 2: 22kV Network Schematic

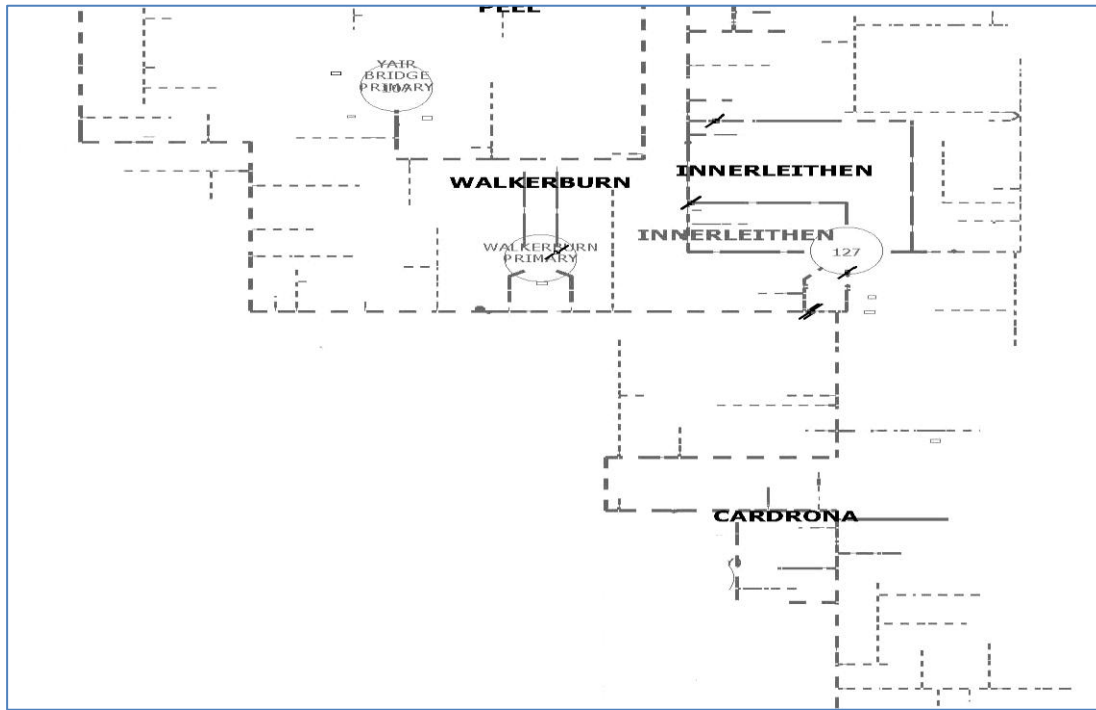

Sample Scheme Papers Annex

Municipality	Whitchurch, Shropshire	Country:	England
Title	Whitchurch Reinforcement	Voltage	132kV & 33 kV
Description	Install a new Grid transformer at Wem Substation to increase thermal capacity		
Due to complete in	2022		

SCOPE

- Install a 132/33kV Grid Transformer at Wem substation
- Build a new 132 kV circuit between Oswestry and Wem substations (~22km)
- Replace the existing 33kV switchboard to accommodate the additional grid transformer

MAP

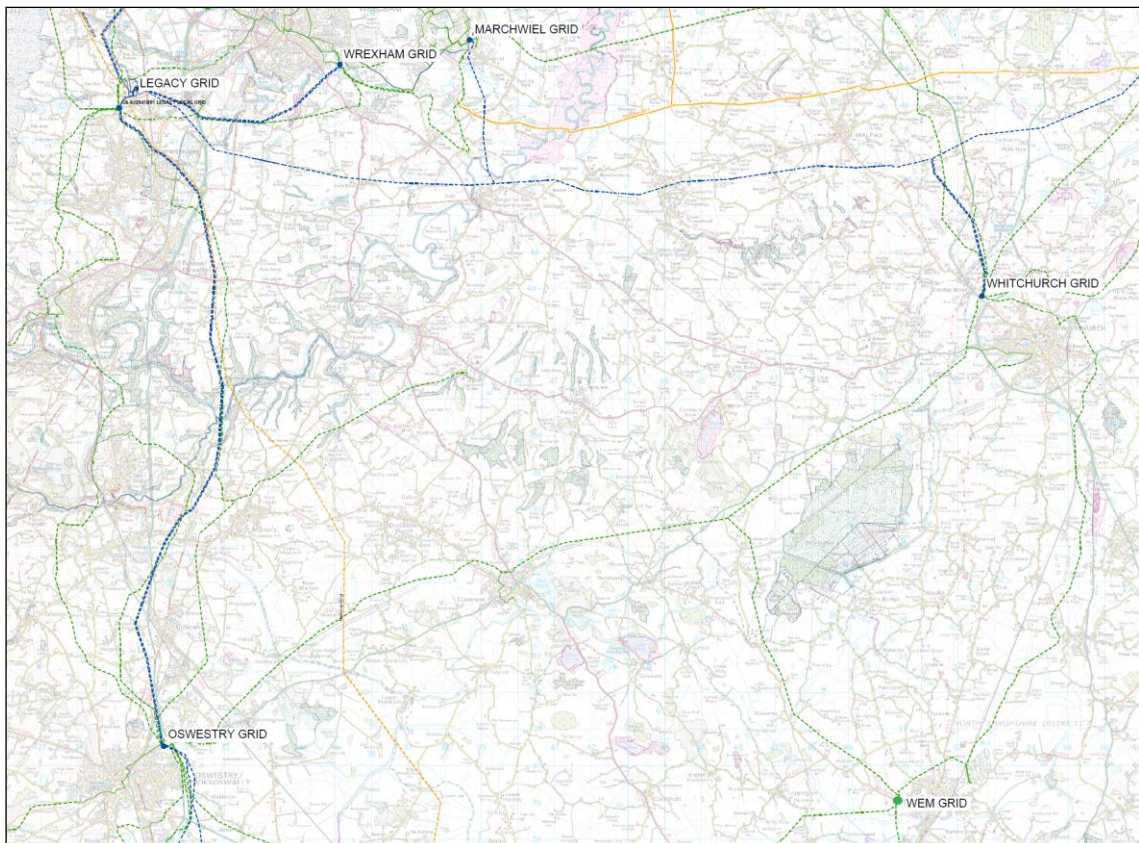

Sample Scheme Papers Annex

DESCRIPTION

The 33kV system in Whitchurch and the surrounding area of Shropshire is currently operating at maximum thermal and minimum voltage limits.

Through stakeholder engagement with the local county council it has been identified that there are significant development plans for the Whitchurch area and concerns are continually being raised about the lack of existing capacity headroom inhibiting growth and development.

In order to comply with section 9 of the Electricity Act and Condition 21 of our license obligation “to develop and maintain an efficient, coordinated and economical system for the distribution of electricity” an enduring design solution is required in order to satisfy the existing demand requirements and accommodate future load growth.

The proposed new grid transformer will meet this requirement, increasing both thermal and voltage capacity to a level that will also provide headroom for anticipated load growth in the area including SPM Best View Scenario for capacity based on WS3 analysis.

SINGLE LINE DIAGRAM

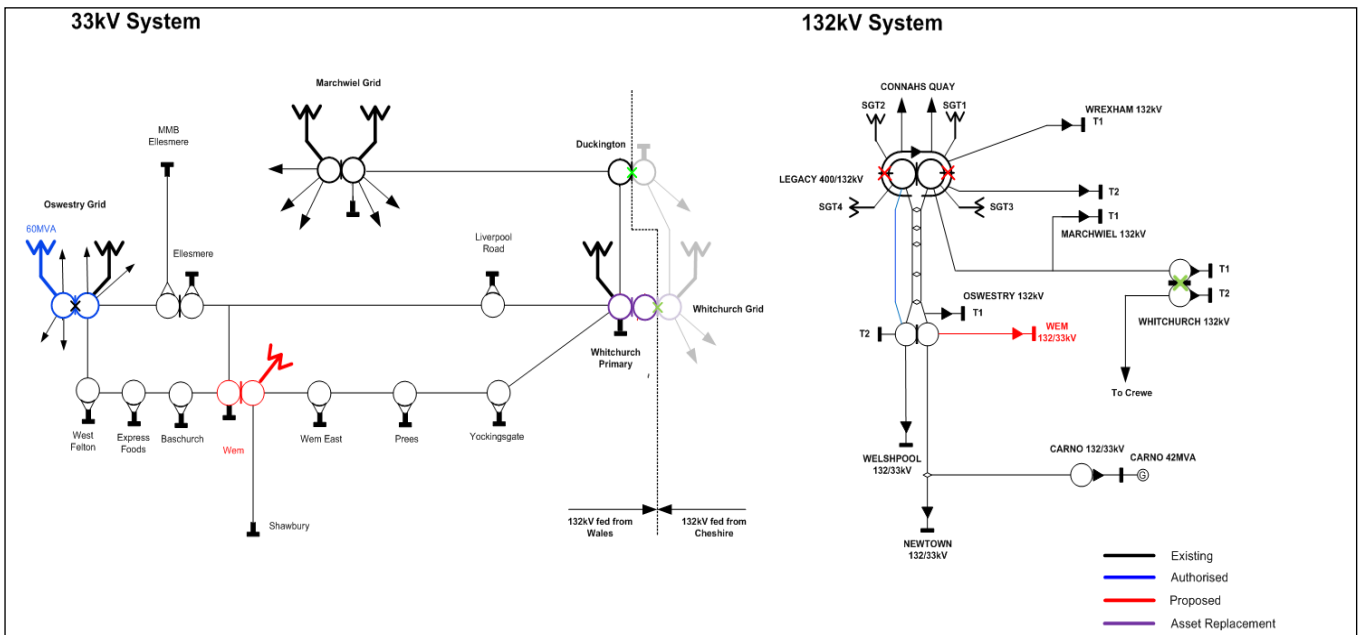

Sample Scheme Papers Annex

Municipality	Liverpool, Merseyside	Country:	England
Title	Substation modernisation	Voltage	132 kV
Description	Birkenhead 132kV Switchgear modernisation		
Due to complete in	2017		

SCOPE:

- Replace 10 bulk oil circuit breakers with a new equivalent GIS solution
- Associated equipment will also be replaced: protections, disconnectors, earth switches, instrument transformers and civil infrastructure.

MAP :



Sample Scheme Papers Annex

DESCRIPTION:

Birkenhead Substation has been identified for modernisation in the RIIO-ED1 period. It is a key node on the 132kV network within the Liverpool area, being a NGC supply point supporting a major part of the Wirral.

The 132kV Switchgear was manufactured and installed in 1966. The ten circuit breakers in situ are, GEC, OFA2 bulk oil circuit breakers, and are deemed to be end of life, category 5 in accordance with SWG-02-008.

The determination of circuit breaker Asset Health utilises our methodology for the assessment of operational adequacy detailed in SWG-02-008. Assessment is by means of a scoring system and the results of the assessment are tabulated in the form of a league table. Utilising the point scoring league table we are able to derive an overall health index. The switchgear types with the highest score towards the top of the table indicating they have the highest priority for replacement

The investment strategy is to target Health Index 5 assets in line with site condition information and our type based operational adequacy methodology SWG-02-008. Due to the volumes of category 5 circuit breakers, our investment plan is planned over two price review periods, targeting the highest criticality sites on a prioritised basis. The reason for this high level of end of life assets is due to the large population of air blast and bulk oil circuit breakers on the network.

These are now defined as being end of life due to the performance, maintenance and supportability issues affecting this equipment. Our strategy to manage this issue is to:

- Replace all of 79 bulk oil and air blast breakers by the end of RIIO-ED2,
- To utilise the decommissioned units to provide spares to keep the other, unsupported, air blast & bulk oil breakers in service.

It is therefore proposed to replace all ten circuit breakers with a new equivalent GIS solution which will reduce the footprint of the 132kV site.

132kV SINGLE LINE DIAGRAM

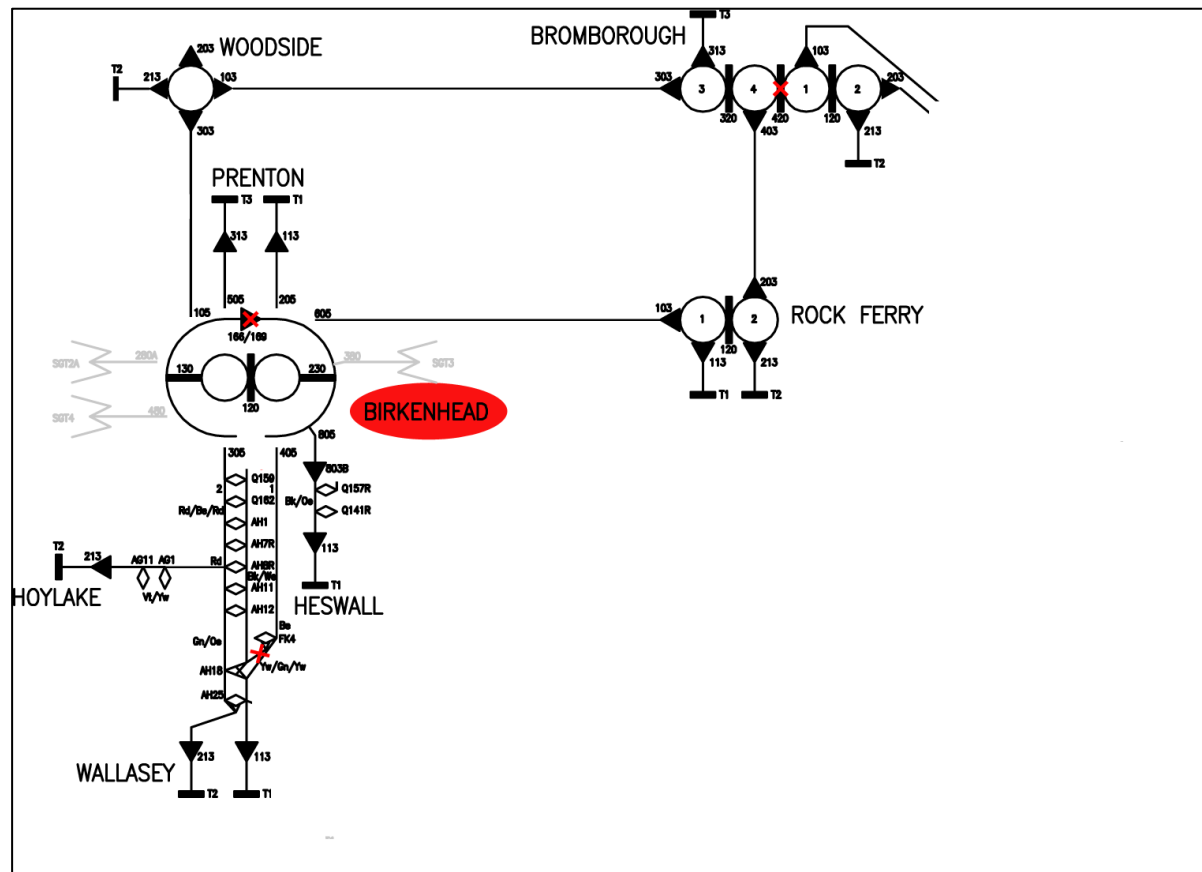

Sample Scheme Papers Annex

Municipality	Crewe, Cheshire, Cheshire East	Country:	England
Title	Substation modernisation	Voltage	132 kV
Description	Crewe 132kV Switchgear & Transformer modernisation		
Due to complete in	2020		

SCOPE:

- Replace 13 bulk oil circuit breakers with a new equivalent GIS solution
- Associated equipment will also be replaced: protections, disconnectors, earth switches, instrument transformers and civil infrastructure.
- Replace Transformer T1 – 132/33kV with a standard 60MVA unit along with associated protections, earthing transformer, 132 disconnector, earth switch, civil and 33kV cable tails

MAP:

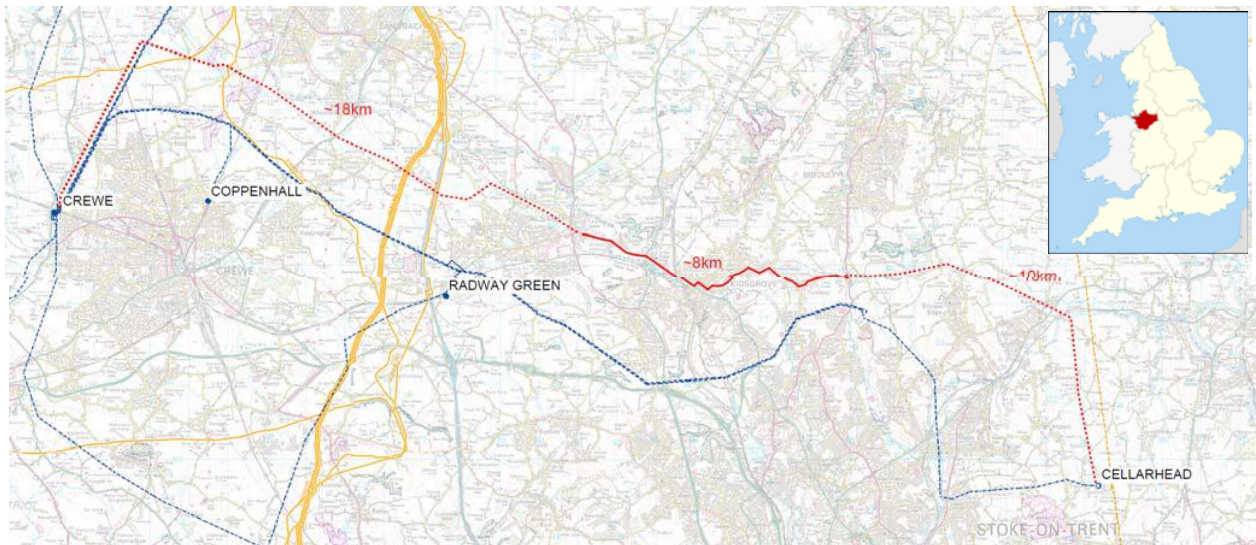

DESCRIPTION:

Crewe Substation has been identified for modernisation in the RIIO-ED1 period. It is a key substation on the 132kV network supporting a mayor part of Cheshire demand.

The 132kV Switchgear was manufactured and installed in 1966. The thirteen circuit breakers in situ are, AEI/Metropolitan Vickers OW410 bulk oil circuit breakers, and are deemed to be end of life, category 5 in accordance with SWG-02-008.

Crewe T1 is a 132/33kV Parsons Transformer manufactured and installed in 1954. This transformer has been categorised as end of life, category 5 in accordance with TRAN-02-022.

The determination of Asset Health utilises our methodology for the assessment of operational adequacy detailed in SWG-02-008 for circuit breakers and TRAN-02-022 for transformers. Assessment is by means of a scoring system and the results of the assessment are tabulated in the form of a league table. Utilising the point scoring league table we are able to derive an overall health index. The asset types with the highest score towards the top of the table indicating they have the highest priority for replacement

The investment strategy for switchgears is to target Health Index 5 assets in line with site condition information and our type based operational adequacy methodology. Due to the volumes of category 5 circuit breakers, our investment plan is planned over two price review periods, targeting the highest criticality sites on a prioritised basis. The reason for this high level of end of life assets is due to the large population of air blast and bulk oil circuit breakers on the network.

These are now defined as being end of life due to the performance, maintenance and supportability issues affecting this equipment. Our strategy to manage this issue is to:

- Replace all of 79 bulk oil and air blast breakers by the end of RIIO-ED2,
- To utilise the decommissioned units to provide spares to keep the other, unsupported, air blast & bulk oil breakers in service.

It is therefore proposed to replace all ten circuit breakers with a new equivalent GIS solution which will reduce the footprint of the 132kV site.

The investment strategy for transformers is to replace assets at or approaching end of life, particularly those with high Dissolved Gas analysis (DGA) readings and poor site specific, condition based assessment ranked through our type based operational adequacy methodology.

132kV SINGLE LINE DIAGRAM

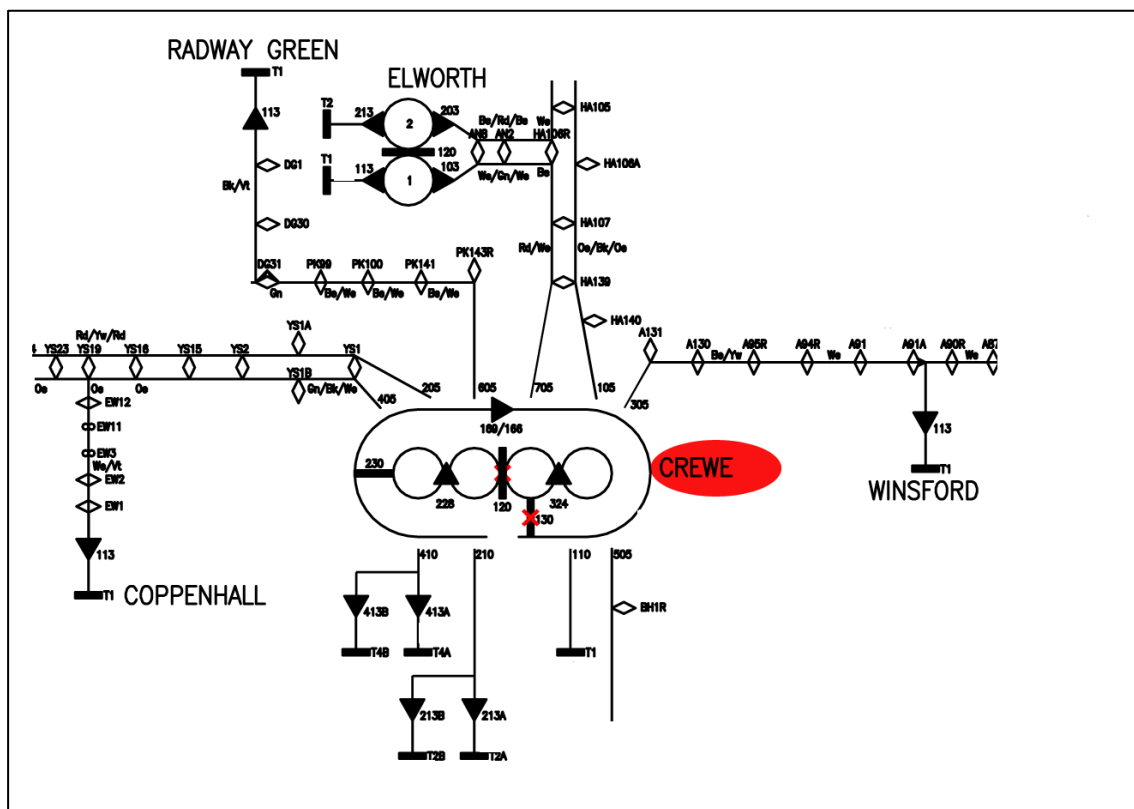

Sample Scheme Papers Annex

Municipality	Liverpool, Merseyside	Country:	England
Title	Substation modernisation	Voltage	132 kV
Description	Lister Drive 132kV Switchgear & Transformer modernisation		
Due to complete in	2019		

SCOPE:

- Replace 10 132kV bulk oil circuit breakers with a new equivalent GIS solution
- Associated equipment will also be replaced: protections, disconnectors, earth switches, instrument transformers and civil infrastructure.
- Replace T1&T2 132/33kV Transformers with 2 standard 60MVA units along with associated protections, earthing transformer, 132 disconnectors, earth switch, civil and 33kV cable tails

MAP:



Sample Scheme Papers Annex

DESCRIPTION:

Lister Drive Substation has been identified for modernisation in the RIIO-ED1 period. It is a key substation on the 132kV network supporting a mayor part of Liverpool city demand.

The 132kV Switchgear was manufactured and installed between 1963 and 1971. The ten circuit breakers in situ are, AEI/Metropolitan Vickers OW410 bulk oil circuit breakers, and are deemed to be end of life, category 5 in accordance with SWG-02-008.

Lister Drive T1&T2 are a 132/33kV Crompton Parkinson Transformer and a 132/33kV Bonar Long Transformer manufactured and installed in 1963 and 1971 respectively. These transformers have been categorised as approaching end of life, category 4 in accordance with TRAN-02-022. However, it is predicted that both these transformers will deteriorate to end of life within the RIIO-ED1 period.

The determination of Asset Health utilises our methodology for the assessment of operational adequacy detailed in SWG-02-008 for circuit breakers and TRAN-02-022 for transformers. Assessment is by means of a scoring system and the results of the assessment are tabulated in the form of a league table. Utilising the point scoring league table we are able to derive an overall health index. The asset types with the highest score towards the top of the table indicating they have the highest priority for replacement

The investment strategy for switchgears is to target Health Index 5 assets in line with site condition information and our type based operational adequacy methodology. Due to the volumes of category 5 circuit breakers, our investment plan is planned over two price review periods, targeting the highest criticality sites on a prioritised basis. The reason for this high level of end of life assets is due to the large population of air blast and bulk oil circuit breakers on the network.

These are now defined as being end of life due to the performance, maintenance and supportability issues affecting this equipment. Our strategy to manage this issue is to:

- Replace all of 79 bulk oil and air blast breakers by the end of RIIO-ED2,
- To utilise the decommissioned units to provide spares to keep the other, unsupported, air blast & bulk oil breakers in service.

It is therefore proposed to replace all ten circuit breakers with a new equivalent GIS solution which will reduce the footprint of the 132kV site.

The investment strategy for transformers is to replace assets at or approaching end of life, particularly those with high Dissolved Gas analysis (DGA) readings and poor site specific, condition based assessment ranked through our type based operational adequacy methodology.

132kV SINGLE LINE DIAGRAM

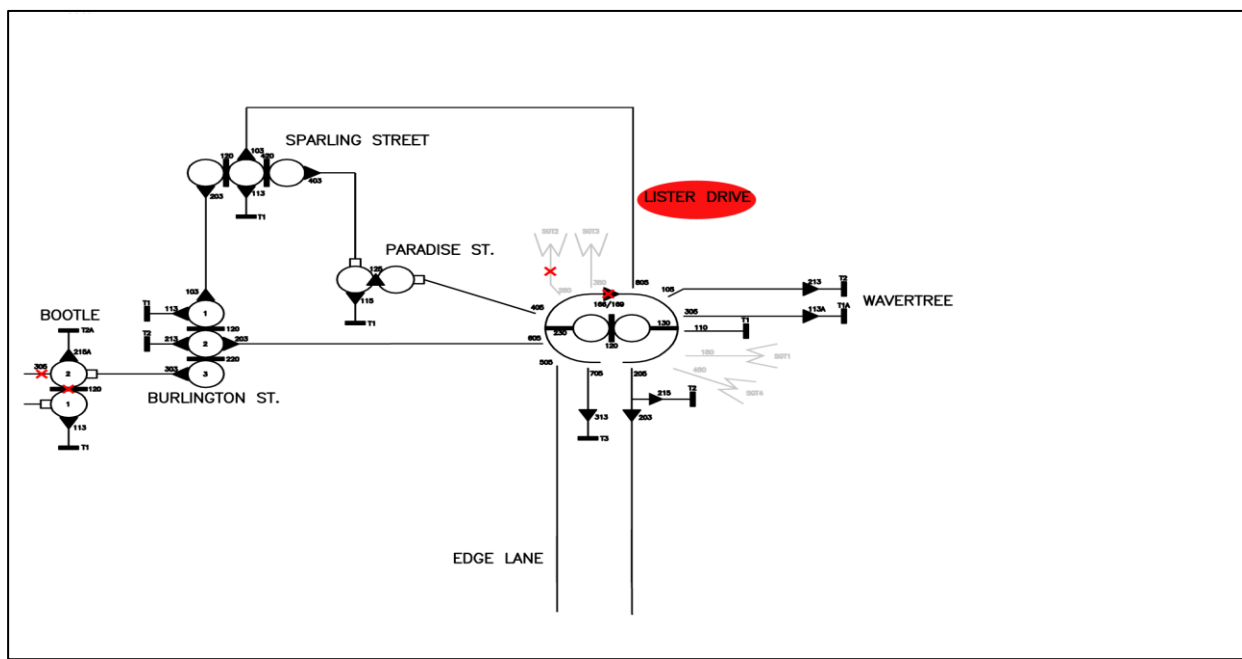

Sample Scheme Papers Annex

Municipality	Rainhill, Merseyside	Country:	England
Title	Substation modernisation	Voltage	132 kV
Description	Rainhill 132kV Switchgear modernisation		
Due to complete in	2021		

SCOPE:

- Replace 12 132kV air blast circuit breakers with a new equivalent GIS solution
- Associated equipment will also be replaced: protections, disconnectors, earth switches, instrument transformers and civil infrastructure.

MAP:



Sample Scheme Papers Annex

DESCRIPTION:

Rainhill Substation has been identified for modernisation in the RIIO-ED1 period. It is a key substation on the 132kV network supporting a mayor part of Merseyside demand.

The 132kV Switchgear was manufactured and installed in 1965. The twelve circuit breakers in situ are, AEI/Metropolitan Vickers GA6 air blast circuit breakers, and are deemed to be end of life, category 5 in accordance with SWG-02-008.

The civils on site have been also categorised as end of life.

The determination of circuit breaker Asset Health utilises our methodology for the assessment of operational adequacy detailed in SWG-02-008. Assessment is by means of a scoring system and the results of the assessment are tabulated in the form of a league table. Utilising the point scoring league table we are able to derive an overall health index. The switchgear types with the highest score towards the top of the table indicating they have the highest priority for replacement

The investment strategy for switchgears is to target Health Index 5 assets in line with site condition information and our type based operational adequacy methodology. Due to the volumes of category 5 circuit breakers, our investment plan is planned over two price review periods, targeting the highest criticality sites on a prioritised basis. The reason for this high level of end of life assets is due to the large population of air blast and bulk oil circuit breakers on the network.

These are now defined as being end of life due to the performance, maintenance and supportability issues affecting this equipment. Our strategy to manage this issue is to:

- Replace all of 79 bulk oil and air blast breakers by the end of RIIO-ED2,
- To utilise the decommissioned units to provide spares to keep the other, unsupported, air blast & bulk oil breakers in service.

It is therefore proposed to replace all twelve circuit breakers with a new equivalent GIS solution which will reduce the footprint of the 132kV site, but consideration should be given to an indoor AIS subject to building refurbishment.

132kV SINGLE LINE DIAGRAM

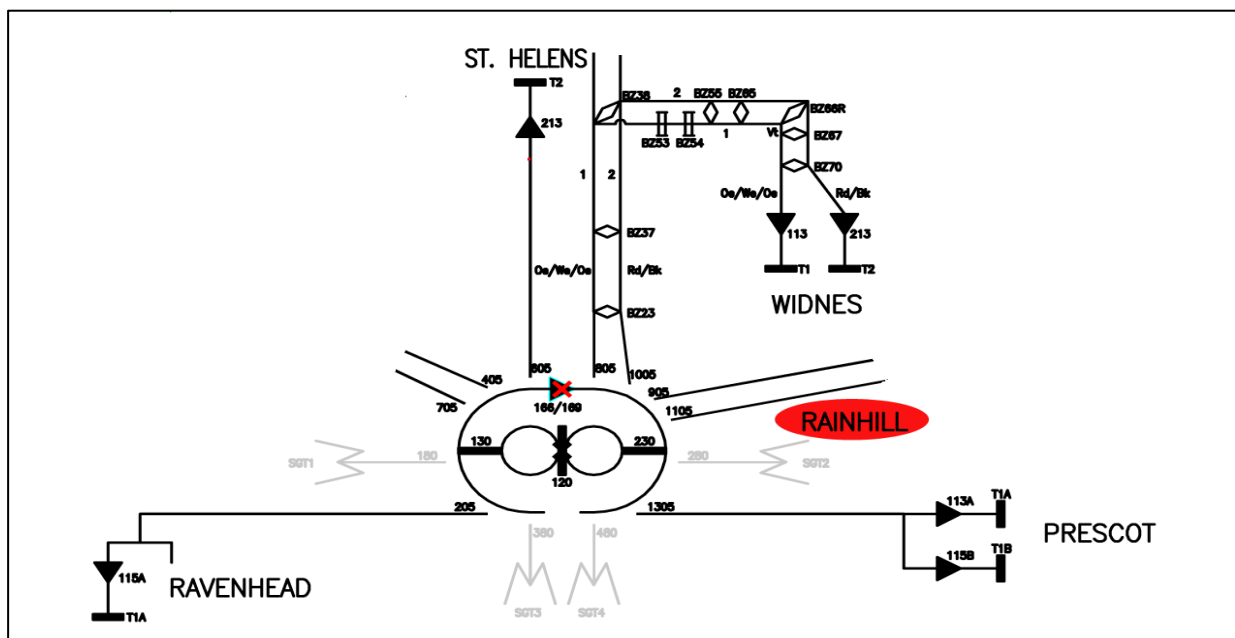

Sample Scheme Papers Annex

Municipality	Flintshire, Clwyd	Country: Wales
Title	AC Route modernisation	Voltage 132 kV
Description	AC Route. Connah's Quay to St Asaph to Dolgarrog 132kV OH Line modernisation	
Due to complete in	2020	

SCOPE:

- Replace all conductors, conductor fittings, insulators, anti-climbing devices and all signage in towers AC001, AC006-AC101 and AC121-AC193
- Replace the earthwire with an equivalent conductor with integral fibre optics (OPGW)
- Ground investigations to assess the condition of the tower foundations and repair/replace where necessary
- All towers painted

MAP:



Sample Scheme Papers Annex

DESCRIPTION:

The AC Route has been identified for modernisation in the RII0-ED1 period due to poor fault performance. The route was constructed in 1952 and has a circuit length of approximately 48.85km.

In 1997 towers AC183 and AC184 were reconducted, but insulators, phase conductors, earth wire and dampers are at end of life. In addition, the steelwork is in poor condition. The asset health indices for this route are as follows:

Foundations	3	Earth Wire	5
Steelwork	4	Earth Wire fittings	3
Insulators	5	Dampers	5
Phase Conductors	5	Signs & Notices	1
Specific Issues	2	ACDs	1

Undertake design works to establish the scope of works for refurbishing/modernising the Connah's Quay to Asaph to Dolgarrog 132kV tower line (BH Route), towers AC001, AC101–AC101 & AC121–AC193. This should include all necessary ground investigations to assess the condition of the tower foundations. Consideration should be given to replace all conductors, conductor fittings, insulators and anti-climbing devices. Foundations should also be repaired and/or replaced where necessary and all towers painted. Consideration should be given to replacing the earth wire with an equivalent conductor with integral fibre optics (OPGW).

132kV SINGLE LINE DIAGRAM

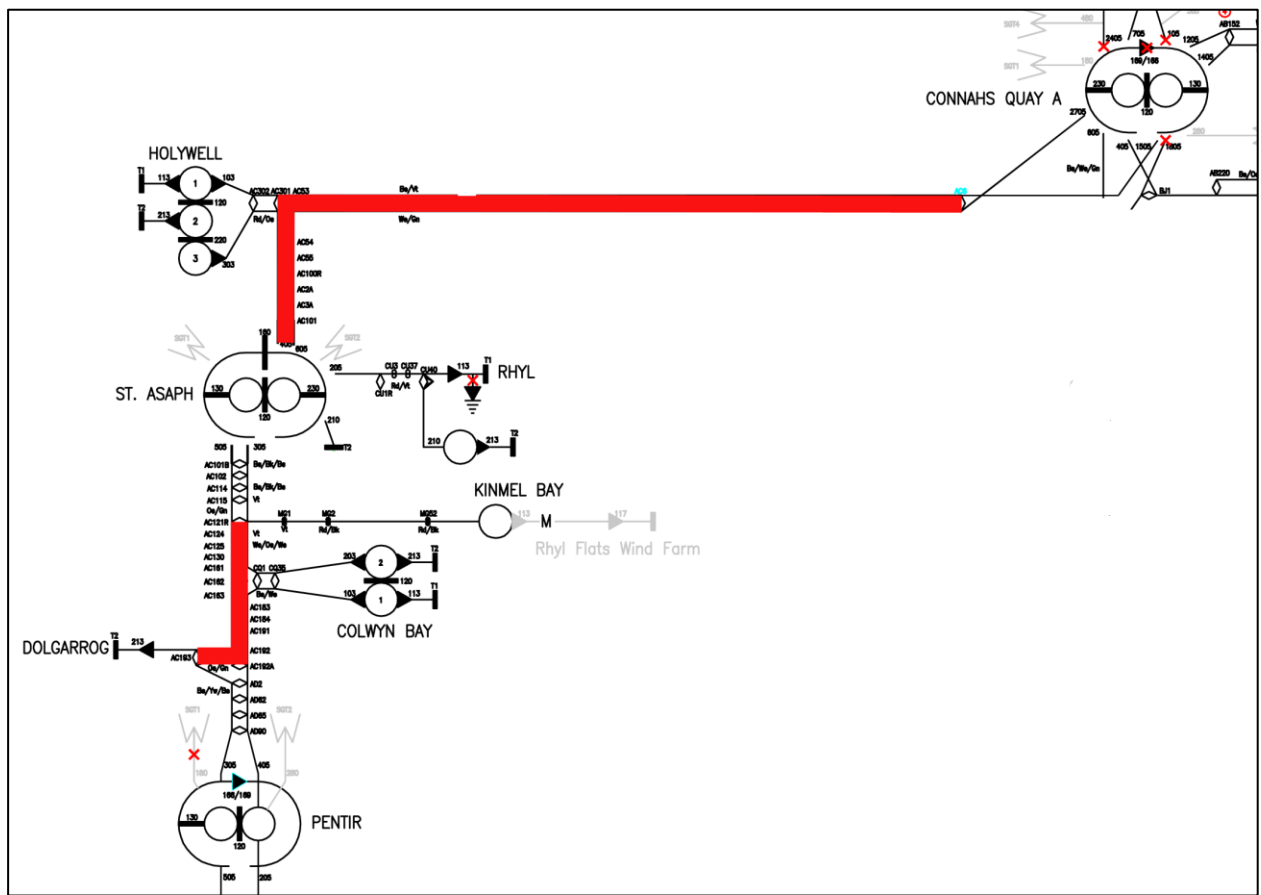

Sample Scheme Papers Annex

Municipality	Crewe, Cheshire East, Northwest	Country:	England
Title	BH Route modernisation	Voltage	132 kV
Description	BH Route. Crewe to Legacy 132kV OH Line modernisation		
Due to complete in	2022		

SCOPE:

- Replace all conductors, conductor fittings, insulators, anti-climbing devices and all signage between towers BH001R-BH104 and BH106-BH220
- Replace the earthwire with an equivalent conductor with integral fibre optics (OPGW)
- Ground investigations to access the condition of the tower foundations and repair/replace where necessary
- All towers painted

MAP:



Sample Scheme Papers Annex

DESCRIPTION:

The BH Route has been identified for modernisation in the RIIO-ED1 period due to poor fault performance. The route was constructed in 1958 and has a circuit length of approximately 42.29km.

The earth wire fittings were replaced in 2007, but the foundations, phase conductors and earth wire are at end of life. In addition, the insulators, dampers, signage and ACDs are in poor condition. Other specific issues are also in poor condition. The asset health indices for this route are as follows:

Foundations	5	Earth Wire	5
Steelwork	3	Earth Wire fittings	1
Insulators	4	Dampers	4
Phase Conductors	5	Signs & Notices	4
Specific Issues	4	ACDs	4

Undertake design works to establish the scope of works for refurbishing/modernising the Crewe to Legacy 132kV tower line (BH Route), towers BH001R – BH104 & BH106 – BH220. This should include all necessary ground investigations to assess the condition of the tower foundations. Consideration should be given to replace all conductors, conductor fittings, insulators, anti-climbing devices and all signage. Foundations should also be repaired and/or replaced where necessary and all towers painted. Consideration should be given to replacing the earth wire with an equivalent conductor with integral fibre optics (OPGW).

132kV SINGLE LINE DIAGRAM

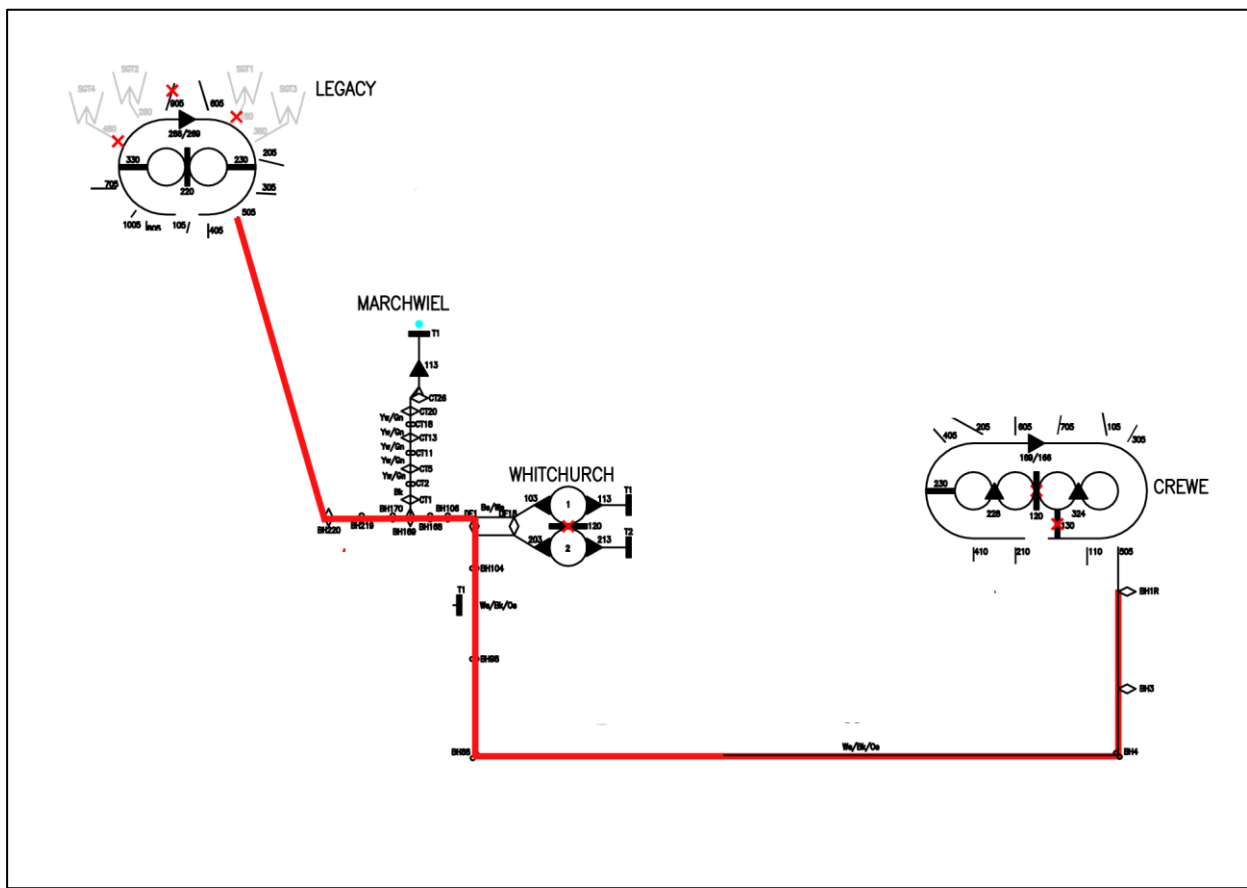

Sample Scheme Papers Annex

Municipality	Crewe, Cheshire, Cheshire East	Country: England
Title	PK Route modernisation	Voltage 132 kV
Description	PK Route. Crewe to Barlaston to Radway Green 132kV OH Line modernisation	
Due to complete in	2021	

SCOPE:

- Replace all conductors, conductor fittings, insulators, anti-climbing devices and all signage.
- Replace the earthwire with an equivalent conductor with integral fibre optics (OPGW)
- Ground investigations to access the condition of the tower foundations and repair/replace where necessary
- All towers painted

MAP :



Sample Scheme Papers Annex

DESCRIPTION:

The PK Route has been identified for modernisation in the RIIO-ED1 period due to poor fault performance. The route was constructed in 1933 and has a circuit length of approximately 38.64km.

Towers PK090-PK127 were reconducted in 1978 and towers PK036-PK143 were painted in 2007, but the phase conductors and earth wire are at end of life, and signage is in poor condition. The asset health indices for this route are as follows:

Foundations	3	Earth Wire	5
Steelwork	1	Earth Wire fittings	3
Insulators	3	Dampers	3
Phase Conductors	5	Signs & Notices	4
Specific Issues	1	ACDs	3

Undertake design works to establish the scope of works for refurbishing/modernising the Crewe to Barlaston to Radway Green 132kV tower line (PK Route), towers PK003–PK143. This should include all necessary ground investigations to assess the condition of the tower foundations. Consideration should be given to replace all conductors, conductor fittings, insulators and anti-climbing devices. Foundations should also be repaired and/or replaced where necessary and all towers painted. Consideration should be given to replacing the earth wire with an equivalent conductor with integral fibre optics (OPGW).

132kV SINGLE LINE DIAGRAM

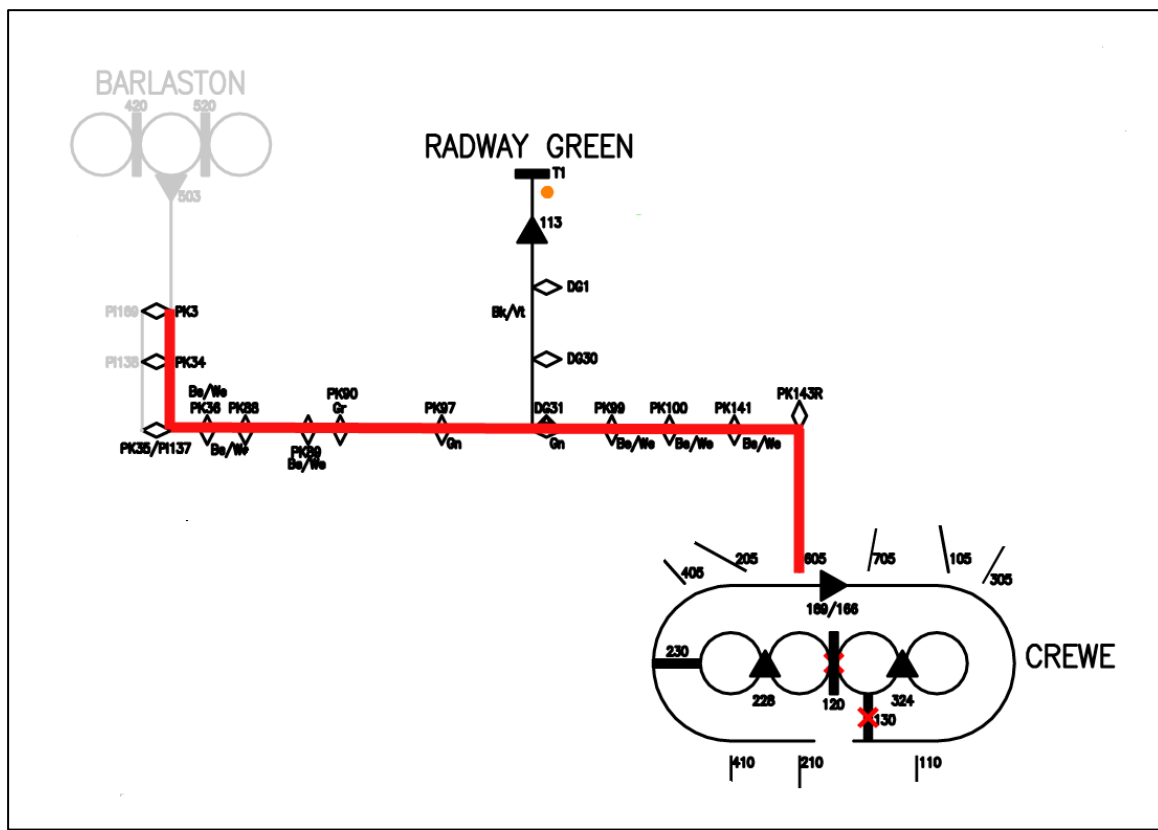

Sample Scheme Papers Annex

Municipality	Crewe, Cheshire, Cheshire East	Country: England
Title	YS Route modernisation	Voltage 132 kV
Description	YS Route. Crewe to Whitefield to Cellarhead 132kV OH Line modernisation	
Due to complete in	2018	

SCOPE:

- Replace all conductors, conductor fittings, insulators, anti-climbing devices and all signage.
- Replace the earthwire with an equivalent conductor with integral fibre optics (OPGW)
- Ground investigations to access the condition of the tower foundations and repair/replace where necessary

MAP:



Sample Scheme Papers Annex

DESCRIPTION:

The YS Route has been identified for modernisation in the RIIO-ED1 period due to poor fault performance. The route was constructed in 1962 and has a circuit length of approximately 35.5km.

Towers YS001-YS071 were painted in 2005/06 but insulators, earth wire fittings and dampers are at end of life and the steelwork is in very poor condition. In addition, the phase conductors, earth wire and the signage are in poor condition. Other specific issues are also at end of life. The asset health indices for this route are as follows:

Foundations	3	Earth Wire	4
Steelwork	5	Earth Wire fittings	5
Insulators	5	Dampers	5
Phase Conductors	4	Signs & Notices	4
Specific Issues	5	ACDs	3

Undertake design works to establish the scope of works for refurbishing/modernising the Crewe to Whitefield 132kV tower line (YS Route), towers YS001–YS102. This should include all necessary ground investigations to assess the condition of the tower foundations. Consideration should be given to replace all conductors, conductor fittings, insulators and anti-climbing devices. Foundations should also be repaired and/or replaced where necessary and all towers painted. Consideration should be given to replacing the earth wire with an equivalent conductor with integral fibre optics (OPGW).

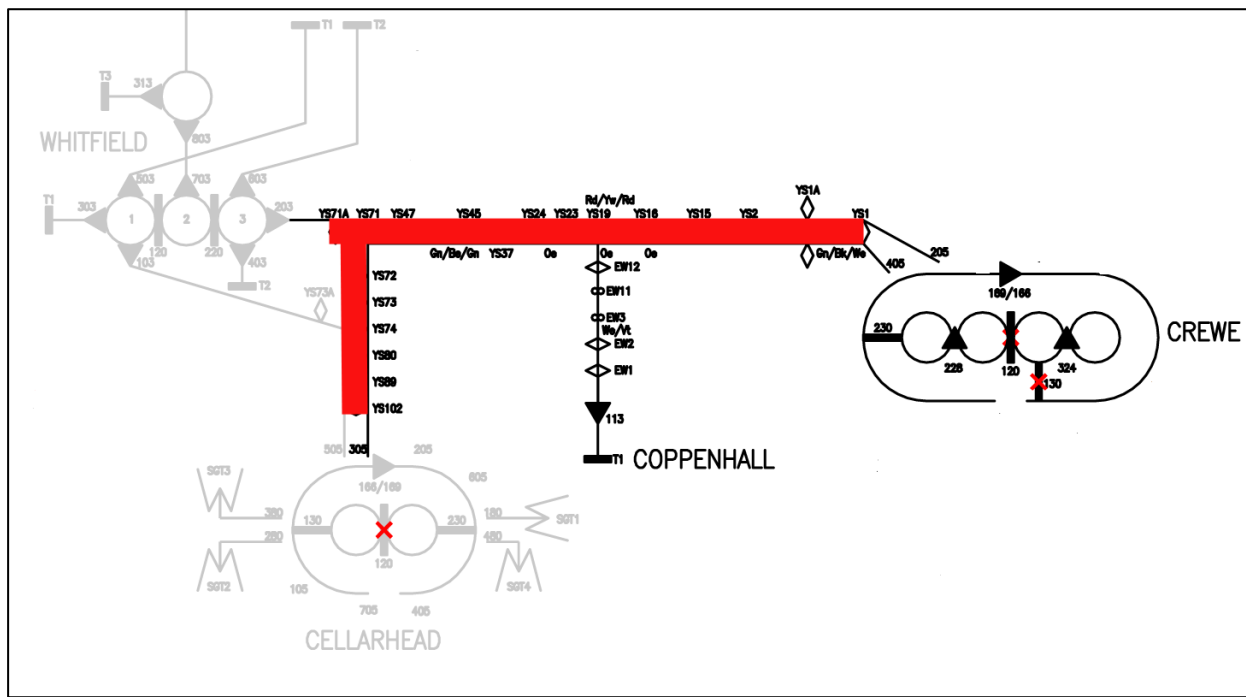

Sample Scheme Papers Annex

Municipality	Liverpool, Merseyside	Country:	England
Title	Cable modernisation	Voltage	132 kV
Description	Kirby to Gillmoss T1 to Fazakerley to Bootle305 UG Cable modernisation		
Due to complete in	2017		

SCOPE:

- Replace 132kV fluid filled cable (10.845 km length).

MAP:

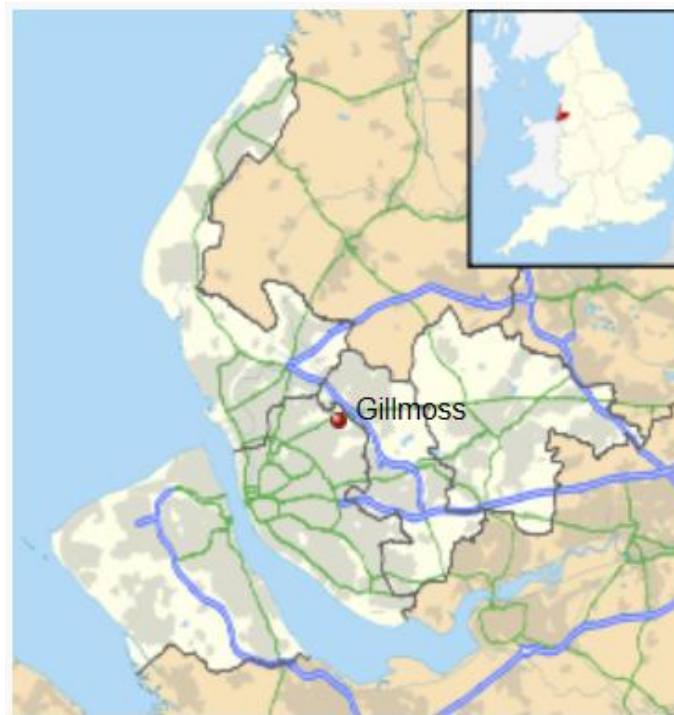

DESCRIPTION:

This fluid filled cable has been identified as health index 5 and requires modernisation in the RIIO ED1 period due to poor performance. The cable has had numerous cable leaks over the last few years with a leakage of 10,000 litres in 2008/09 alone. These leaks have caused substantial environmental problems and it has reached its end of life. It is 10.845 km in length.

Undertake design works to establish the scope of works for replacing the Kirby to Gillmoss T1 to Fazakerley to Bootle 305 132kV fluid filled cable.

132kV SINGLE LINE DIAGRAM

