

RIIO NIC 2015



Future Intelligent Transmission Network SubStation
(FITNESS)

| | |
|-----------------|--------------|
| Project Number: | Code/Version |
| SPTEN02/V2 | |

Section 1: Project Summary

| | |
|----------------------------------|--|
| 1.1. Project Title | Future Intelligent Transmission NE twork SU bStation (FITNESS) |
| 1.2. Project Explanation | FITNESS will deliver the pilot GB live multi-vendor digital substation instrumentation system to protect, monitor and control the transmission network using digital communication over fibre to replace copper hardwiring, reducing cost, risk and environmental impact, and increasing flexibility, controllability and availability. |
| 1.3. Funding licensee: | SP Transmission Plc (SPT) |
| 1.4. Project description: | <p>Problems. Efficient and effective investment in power networks is the key to balancing the energy trilemma of security, cost and reliability. Networks are handling significant increases in volumes of low carbon energy at the same time as large parts of the existing asset base are approaching the end of life. This is driving a continued increase in requirements for new and modernised substations and a need for lower cost and more flexible solutions around substation design, enabling optimum use of existing assets while reducing system outage requirements around maintenance and construction.</p> <p>Methods. New standards for substation design are applied to introduce new measurement, monitoring, protection and control technologies with digital communications. Multi-vendor interoperability is demonstrated in an offline environment and then in a pilot GB sub-station field operation trial. In addition, integration and interaction with external control and central monitoring is proven through FITNESS.</p> <p>Solutions. Smaller, lighter, safer equipment, with greatly reduced cabling at substations. Standardised secondary monitoring, protection & control equipment added/replaced without planned outage requirements. Integrated data wide area monitoring and control improving observability and control flexibility and accelerating integration of low carbon technologies.</p> <p>Benefits. Lower substation build/modernisation cost, reduced outage time and constraints, improved safety, reduced environmental impact, and greater operational flexibility leading to more efficient use of assets. The key benefits after successful completion of project FITNESS by end of RIIO T2 are</p> <ul style="list-style-type: none"> • 10% reduction of substation new-build and replacement costs, equating to £71m-£107m • 4-5% reduction of constraint payments equating to £27m-£80m. • Carbon savings equating to £13m-34m through reduction in constraints and reduced use of copper in substations |

| | | | |
|---|--|---|---|
| 1.5. Funding | | | |
| 1.5.1 NIC Funding Request (£k) | 8335 | 1.5.2 Network Licensee Compulsory Contribution (£k) | 945 |
| 1.5.3 Network Licensee Extra Contribution (£k) | N/A | 1.5.4 External Funding – excluding from NICs (£k): | 1545 |
| 1.5.5. Total Project Costs (£k) | 10998 | | |
| 1.6. List of Project Partners, External Funders and Project Supporters | Project Partners: ALSTOM Grid (£1m in kind contribution) ABB (£0.395m in kind contribution) Academic Partner: University of Manchester (£0.15m in kind contribution) SME Partner: Synaptec Project Advisory Board: NGET, SHE TL, PAC World | | |
| 1.7 Timescale - 4 years | | | |
| 1.7.1. Project Start Date | April 2016 | 1.7.2. Project End Date | March 2020 |
| 1.8. Project Manager Contact Details | | | |
| 1.8.1. Contact Name & Job Title | Priyanka Mohapatra Senior Project Manager | 1.8.2. Email & Telephone Number | pmohapatra@spenergynetworks.co.uk +44 (0)1416142789 |
| 1.8.3. Contact Address | Scottish Power Energy Networks Ochil House, 10 Technology Avenue, Hamilton International Technology Park, Blantyre, G72 0HT Scotland | | |

Section 2: Project Description

Future Intelligent Transmission Network Substation (FITNESS) proposes a reduced outage and low risk approach to future substation monitoring, protection, automation, and control, by enabling faster deployment, greater availability, improved safety and greater controllability with a reduced footprint and lower cost than conventional design. The solutions enabled by FITNESS facilitate reduced network costs and constraints feeding through to significant benefits for GB customers. The goal of FITNESS is to enable GB Transmission Owners (TOs) and Distribution Network Owners (DNOs) to apply a digital substation design approach to future load and non-load related investment after successful demonstration. Digital substations are based on concepts of standardisation and interoperability, and enable replacement of many kilometres of copper wiring with digital measurements over a cost-effective fibre communications network, and provide much greater flexibility in building, instrumenting, maintaining, modernising and controlling future substations.

FITNESS is globally innovative and is the pilot live digital substation demonstration in GB. Its ambition is to address complete substation functionality for monitoring, protection and rapid grid-sensitive control using digital architecture, to meet the emerging needs and dynamics of a low carbon network and accelerate integration of low carbon technologies. Experience of demonstrating interoperability between vendors will offer key learnings for industry stakeholders worldwide and identify any gaps in interpretation of standards for international standards committees.

FITNESS is proposed to bridge the gap between the limited trials completed to date and the full system integration and experience of the substation instrumentation system required to make a strategic step change of the business-as-usual practice to the design of substations from RIIO-T2 onwards. Key innovations include:

1. **Integration of protection, monitoring and control** functions in a digital substation using a digital bus architecture, in contrast to previous trials of individual subsystems, mainly of protection only.
2. **Novel sensor technology** includes Non-Conventional Voltage Transformers (NCVTs) and distributed optical sensor technology, not yet commercially released, integrated with the substation instrumentation.
3. **Live operation** of the digital substation, including active protection, with multi-vendor interoperability. This proves technology readiness of multiple vendors, and the maturity of the standards to achieve interoperability, and the proof is essential before the technology can be deployed as business-as-usual.
4. **Information co-ordination** showing the use of novel measurement sources to satisfy current and emerging information services without the conventional constraints on connecting devices, and demonstrating new analysis capabilities in fields of synchrophasors, fault diagnostics and harmonics.
5. **Wide area control infrastructure**, providing the substation functionality to support emerging quality and latency requirements for frequency and stability controls, and constraints management.

2.1. Aims and objectives

Problems to be resolved

Together with the GB Transmission Licensees, SPEN faces a continuing challenge to meet emerging needs related to increasing levels of low carbon technologies, changes in generation and load profile and an aging asset base. FITNESS aims to address the following problems:

- System operational requirements allow only very **limited outage time windows** when circuits can be taken out of service, which conflicts with the business needs for **aging asset replacement, modernisation and new building work**.
- Conventional substations allow **little flexibility** for adopting new monitoring, protection and control functions, especially where it is linked with external measurements and information systems. **Retrospective additions** of monitoring, protection and control outside modernisation windows are difficult to implement non-intrusively and are prone to long delays.
- Inadequate **quality of measurement** from conventional instrument transformers prohibiting the use of wide area monitoring and control technologies and applications.
- Moisture ingress or drying out of oil seals in an instrument transformer may lead to failure, which would result in a long outage to source, install and commission a replacement. There is also an inherent **safety hazard** in conventional substation equipment and cabling between primary high voltage equipment and the secondary control instrumentation. Working practises are used to effectively mitigate the risk, but often at the expense of cost and outage time.
- Environmental pressures mean that **space is at a premium**, particularly with substation new-build or expansion projects.
- To harness benefits of emerging technology, it is necessary to **prove capability and learn skills** before adopting it as business-as-usual, to manage risks. Technology proving must include deployment experience in a **live** environment, with the level of **interoperability** required in business-as-usual.

Control and protection requirements are changing significantly as low carbon generation and DC interconnections increase. Previously, a large proportion of high inertia synchronous generation limited the rate of frequency changes, so that frequency-based load shedding and islanding were rare. Predominantly synchronous generation also supplied large currents during faults that protection devices detected and acted on. In future scenarios, generation technology changes will greatly reduce inertia and fault currents. Novel approaches are required to avoid large load-shedding and islanding events, or the potentially catastrophic and hazardous effects of protection failing to operate. Continuing traditional network control and protection practice in future low carbon scenarios could result in very costly constraints and/or exposure to risk. Infrastructure is needed in modern substations to enable new control and protection concepts to be implemented.

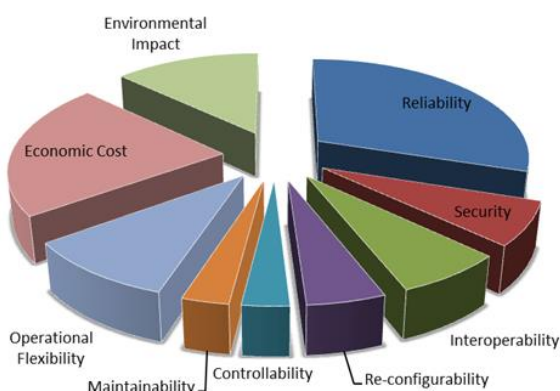

There continues to be a high rate of transmission network asset additions and replacement required because of aging assets and increased generation. The rate of load and non-load related investment is limited by available outage windows, resulting in aging infrastructure becoming less reliable, delaying capacity addition and leading to constraints.

Figure 1 Weighting Criteria for Future Substation Design

These issues are now seriously challenging the sustainability of secondary system assets, which threaten the required availability and reliability of electricity transmission and distribution networks as governed by the National Electricity Transmission System Security

and Quality of Supply Standards (NETS SQSS)¹. To address the growing concerns surrounding substation asset replacement and load related investment a shift in design focus is required. The historic focus for substation design criteria has been mainly on costs and reliability. The new emerging criteria based on current energy scenario extend beyond **costs and reliability** to **operational flexibility, environmental impact, maintainability, interoperability, re-configurability and controllability**. Typical relative weightings for the different drivers for substation planning are presented in Figure 1².

There are new technologies and standards that can enable transmission and distribution owners to meet the emerging needs for intelligence in the substation. However, the industry is faced with a major challenge to introduce a step change in design, replacing a decades-old established and reliable practice, with new technology which the industry is in the process of gaining experience, largely through off-line trials. Because protection is so critical to the safety and integrity of the system, this technology cannot be accepted into business-as-usual practice without risk management by parallel live trials. The FITNESS approach of parallel live conventional and innovative technology is a critical bridge between previous trials and future business-as-usual deployment.

Methods being trialled

The FITNESS project is trialling a new digital substation architecture that significantly reduces the number and duration of circuit outages required throughout the life cycle of the substation. The core methods being trialled involve the end-to-end chain from novel measurements technology, through digital communication (replacing analogue wiring), to the diverse protection, monitoring, control and analysis applications based on the measurement data to demonstrate operation and progressing to business-as-usual:

- **Measurement.** The Process Bus standard enables integration of smaller, lighter and higher quality sensors. The project is intended to prove that Non-Conventional Instrument Transformers (NCITs) and merging units (MU) can be integrated with protection, monitoring and control, and that the data quality is sufficient to fulfil the functions of multiple conventional instrument transformers, reducing footprint and environmental impact. Trials include **substation NCITs** (fulfilling protection needs), **distributed NCITs** (applicable to hybrid overhead/underground lines) and **conventional instrument transformers connected via merging units (MU)** all integrated using IEC 61850-9-2LE standard, to achieve a practical roadmap for introducing the process Bus architecture
- **Digital Communications.** The substation will be designed with digital communications over fibre optic cables instead of analogue signals over copper cables from switchyard to control building. The method relies on the recent IEC 61850-9-2LE³ *Process Bus* standard (see Technical Description) for publishing digital sampled values. The project proves the accuracy of definition of the standards and the interoperability of multi-vendor products and integrated systems designed according to this standard.
- **Protection** using only digital communications, and no analogue hardwiring, so that protection devices are smaller and can be replaced or reconfigured without any change of wiring within the switchyard and therefore avoiding circuit outages. The **reliability, configurability, availability** and **interoperability** of **multi-vendor** protection

¹ NETS SQSS: <http://www2.nationalgrid.com/uk/industry-information/electricity-codes/sqss/the-sqss/>

² "The 21st century substation design: Vision of the Future" Mladen Kezunovic, 2010

³ International Electrotechnical Commission (IEC), Technical Committee TC57, IEC 61850 standard for the design of electrical substation automation, www.iec.ch

schemes in the new architecture in a live substation environment are the key outcomes of this method.

- **Monitoring.** The project will assess the quality and accuracy of the end-to-end data stream from point of measurement to central information and control systems. This is important for synchrophasor measurements (for system dynamics), fault management, SCADA and power quality functions.
- **Control.** To prove that substation control processes can be applied in the IEC 61850 based substation design. In particular, to assess that wide area monitoring and control, as explored in other NIC, NIA and IFI projects can be enabled and rolled out more readily in the proposed architecture compared to conventional substations. The project should prove that a flexible control structure capable of fast response to grid conditions can be applied and configured to meet emerging needs.
- **Substation management,** including supervision, remote access and integration to central information systems is to be proven. The project intends to prove that multi-vendor equipment is interoperable and can be managed in an integrated system. Cyber security risk is also assessed and addressed as a part of this method.

The elements listed above will be trialled according to the criteria for modern substation design shown in Table 1. The project will include a progression of:

- **Design** to include architecture, reliability analysis, logical/physical design and costs
- **Lab testing** to prove interoperability, procedure learning, accuracy and performance testing
- **Live system testing** through full on-site installation, leading to full end-to-end live performance trials, with a redundant conventional system for risk management.

| Design Drivers | FITNESS Methods |
|---|--|
| Economic Cost Environmental Impact Maintainability | -Reducing outage and asset cost by replacing hardwired copper cabling from switchyard to cubicle with digital optical fibre. -Non-conventional measurements to replace large oil-filled transformers, unified to serve all protection, monitoring & control needs. -Flexible digital substation architecture with suitable 'plug and play' technology allows fast and easy modernisation or replacement of measurement, monitoring, protection or control equipment. |
| Reliability Interoperability (internal to substation) | -Availability improved by significantly reducing time-to-restore, through hot-standby protection (use of digitised CT and VT measurements over fibre communications network (process bus) means that in the event of device failure, an adjacent protection device can automatically consider the SV data and replace the failed or damaged device without need for manual intervention). -Interoperability between manufacturers' protection equipment, enabling design diversity. -Integration with 3 rd party novel sensor technology. |
| Interoperability (external) Operational flexibility Controllability Re-configurability | -Interoperability proven between substation and central information systems using standard protocols. -Operational flexibility through adapting to varying low carbon penetration. -Controllability achieved by flexible, fast control, responsive to wide area measurements and triggers. -Re-configurability by processes to change protection parameter, scheme or hardware, and add new monitoring & control with little or no outage. |
| Security | -Applying physical security and cyber security practices to manage risks of unauthorised access to protection and control. |

Table 1 Methods addressing Substation Design Drivers through FITNESS

Demonstrations being undertaken

The FITNESS demonstrations will be incorporated alongside the design and implementation of one of the planned business-as-usual asset replacement programmes. It will enable the network planning regulation, engineering services, commissioning and operations teams to gain hands-on experience of the digital substation concept throughout the project. The demonstrations are designed to prove the readiness of the technology to address protection, monitoring and control needs without loss of conventional

functionality. The design trials are intended to confirm the expected benefits of the approach in terms of reduced outage time and environmental impact and improved data quality, reliability of substation secondary systems. There are five work packages, comprising of substation design, substation performance, substation-to-system information and control integration, security and knowledge dissemination. The detailed demonstrations being undertaken are described in section 2.3.

FITNESS through its multi-vendor demonstration will also identify any potential gaps in international standards' definitions for IEC 61850-9-2. FITNESS is GB's first and, to the best of our knowledge, one of world's very few multi-vendor fully integrated and standardised wide area monitoring, protection and control demonstration.

Solutions enabled

The key learnings after successful completion of FITNESS enable a process for roll-out of the digital substation solutions for GB TOs and DNOs (Figure 2), including:

- Non-conventional measurements;
- Process Bus communication of measurements for monitoring, protection and control, and actuation signals;
- Interoperability within the substation, and with external information systems;
- Integration with wider automated control systems.

Table 2 outlines the solutions that are enabled according to the design drivers of the future substation.

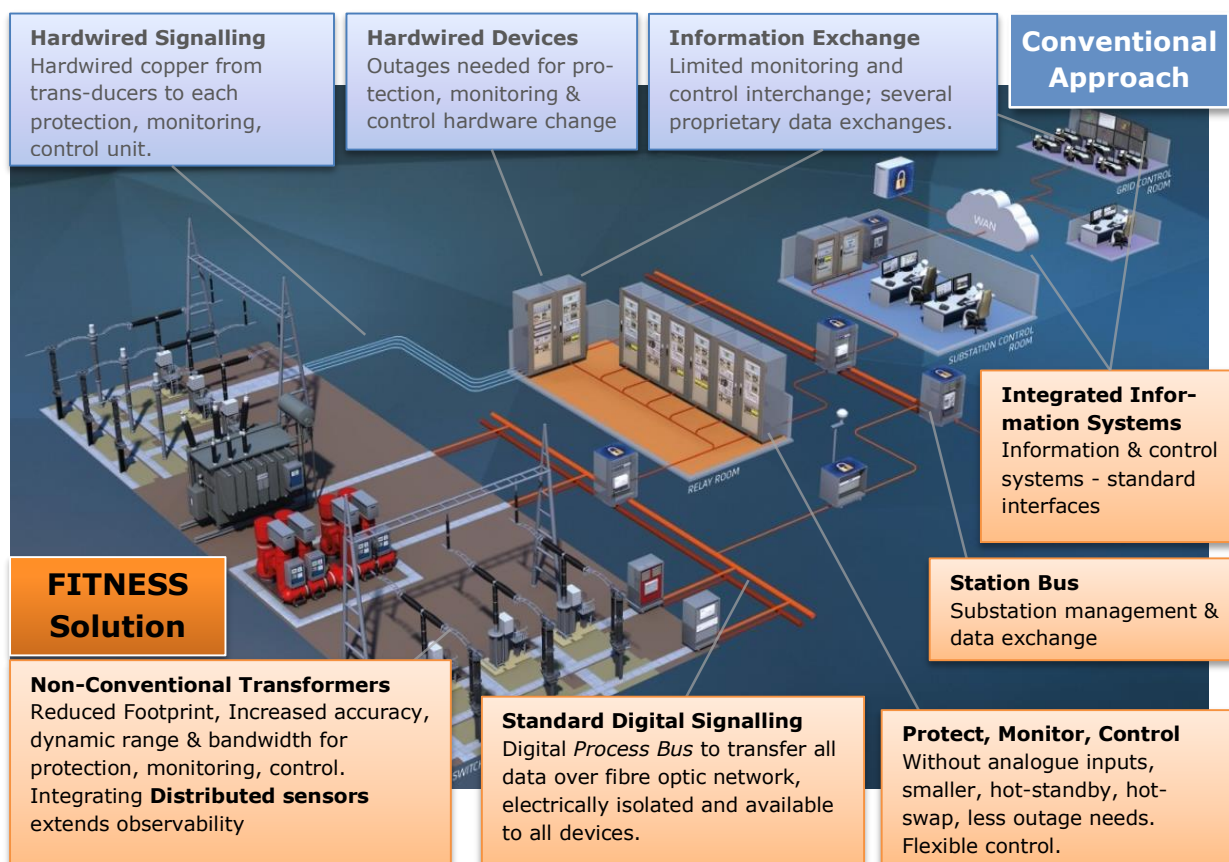

Figure 2 FITNESS Digital Substation Demonstration

| Design Drivers | Solutions Enabled |
|--|---|
| Economic Cost Environmental Impact | <ol style="list-style-type: none"> 1. Build and refurbish substations using a fully digital architecture, enabling: <ol style="list-style-type: none"> a. Much shorter outage window; b. Lower project cost and onsite time; c. Reduced footprint and related cost. 2. Introduce Process Bus with either NCITs or conventional transformers, in new-build or modernisation, greatly reducing cabling and ducting costs. For NCITs replacing oil-filled copper-connected transformers, reduced requirements for foundations and structures. 3. Reduced footprint due to smaller size and weight of transformers, through reduced support structures, cable trenches, civil works. 4. Smaller relay rooms, as devices are smaller without analogue transformers and cabling is greatly reduced. 5. Substation build & modernisation process with much less circuit outage time reduces curtailment of low carbon or energy-efficient generation. |
| Maintainability Reliability Operational flexibility Re- configurability | <ol style="list-style-type: none"> 1. Modular substation design and redundant architecture, hot standby and hot swap allows updates, device addition and replacement without circuit outages. 2. Substation management tools to enable process for secure remote access for configuration, avoiding site visits. 3. Automating protection settings choice in response to system observation, e.g. for varying short circuit levels. |
| Interoperability | <ol style="list-style-type: none"> 1. Interoperable equipment enables design diversity to be applied in digital substations. 2. Interoperability of non-conventional instrumentation at one bay, with conventional instrumentation in the rest of the substation, and at the remote line-end enables single-end bay modernisation. 3. Detailed and validated information made available from the substation to central functions such as Energy Management System (EMS), Wide Area Monitoring System (WAMS), fault management and harmonics. The use of appropriate standards for transferring data at appropriate resolution and quality enables modular solutions rather than tied proprietary hardware and software systems. 4. Use of standardised naming conventions and referencing throughout the network to manage large scale information resources and “big data” (using Common Information Model, CIM) |
| Controllability | <ol style="list-style-type: none"> 1. Infrastructure to enable flexible wide area controls to be implemented to operational requirements, thus facilitating frequency control and network stability, including EFCC (fast frequency control) rollout: <ol style="list-style-type: none"> a. Ability to supply robust data to wide area automated control; b. Ability to incorporate incoming measurements in control schemes. The flexible control supports other use cases, such as the Scotland-England boundary constraint relief options proposed in the Smart Transmission Zone NIA project. |
| Security | <ol style="list-style-type: none"> 1. Enable remote access to substation configuration with cyber and physical security addressed. |

Table 2 FITNESS Solutions Enabled Relating to the Design Drivers

2.2. Technical description of the project

FITNESS is primarily intended to prove that the technology and standards for a digital substation are sufficiently mature to be deployed post-project as the business-as-usual choice for future substation designs. This involves proving that the technical step changes to digital substations can be achieved reliably and confidently. The innovative architecture of the digital substation supports the functions and flexibility required in future substations.

Conventionally, measurements are made by Voltage Transformers (VTs) and Current Transformers (CTs) that connect to the primary equipment. The analogue electrical measurements are transmitted over copper wires from the primary plant to the secondary protection and control cubicles. The signals are connected to secondary transformers and analogue acquisition within each of the many secondary monitoring, protection and control devices. There is therefore a considerable wiring effort to connect the primary CTs and VTs to the secondary devices, and the electrical connection requires particular attention to safety processes and isolation.

Digital substation concept

The design concept for the digital substation is defined in the IEC 61850 standards for communication networks and systems for substations. Specifically, the IEC 61850 9-2 standard (Process Bus), describes the digitisation of measurements within a substation and how conventional or non-conventional CT and VT analogue signals are digitised into sampled values through merging units. With IEC 61850 9-2, primary measurements are digitised once close to the location of the equipment and are communicated to all intelligent electronic devices (IEDs). Each IED subscribes to the digitised measurement data published over an ethernet-based fibre optic network. The digital communication replaces extensive copper wiring required from CTs and VTs to relays, meters IEDs and SCADA system in conventional substations. It thus isolates the primary and secondary equipment. Each secondary device receives its input data via a fibre communication network interface to the process bus, avoiding the need for every IED to incorporate an analogue interface to receive and digitise the electrically noisy signals from primary CTs and VTs. Furthermore, the IEC 61850 8-1 standard includes Generic Object Orientated Substation Event (GOOSE) messaging, which is applied by protection IEDs to transfer their output tripping signals over the process bus without hardwired signalling.

Importantly, this change means that monitoring, protection and control devices such as relays, Phasor Measurement Units (PMUs), Waveform Monitoring Units (WMUs) can be connected to a standardised Ethernet interface without an outage of the circuit, and reconfigured in software without any physical change to CT and VT circuits. This enables a hot standby device to take over the role of a failed or disabled device through software reconfiguration, which is impossible with the hardwired approach. Since ethernet topology is scalable and future proofed, the impact of future developments and updates on the protection and control scheme will be minimised.

It is critical for business-as-usual implementation of the digital substation that protection is interoperable between manufacturers across the process bus. The design diversity principle requires that equipment from at least two separate manufacturers is used in parallel to avoid common-cause failure. Historically, there was less need for interoperability because each device sent and received signals using separate, independent hardwired channels. In the digital substation, devices share common sampled value measurements, communications and switchgear control signals. Multi-vendor interoperability is core to the design philosophy, and will be demonstrated by the FITNESS partners.

The process bus and digitisation within the high voltage equipment area enables new-concept sensors to be used (Non-Conventional Instrument Transformers, NCITs) that could not be used in the conventional analogue approach, as shown below. These NCITs satisfy diverse range, accuracy and bandwidth. Historically multiple sensors and signal paths were required for protection, monitoring, fault recording and power quality measurement.

| Conventional Instrument Transformers (CTs/VTs) | Non-Conventional Instrument Transformers (NCITs) |
|--|--|
| Protection CT/VTs require large dynamic range, with low accuracy, to capture behaviour during a fault | Single device that is <ul style="list-style-type: none"> • Linear over wide dynamic range, satisfying protection requirements. • Accurate to measurement requirements • High bandwidth for power quality and harmonics |
| Measurement CT/VTs require high accuracy and medium speed of response, for measuring system behaviour | |
| Power Quality requires wide frequency bandwidth to capture harmonics up to 50 th or even 100 th | |

Table 3 Comparison of Conventional and Non-Conventional Instrument Transformers

Wider system integration

While previous IEC 61850 projects have focused on the protection devices, a practical application of the digital substation must also deliver monitoring and control facilities. FITNESS therefore includes disturbance monitoring, synchrophasor measurement and power quality measurements. This demonstrates that the digital substation provides data of sufficient quality for these functions. It also demonstrates opportunities for new approaches to delivering the information services using standard interfaces rather than standalone proprietary systems. This will prove how the measurement data available – potentially from multiple locations – could enable faster-acting and more discriminative protection functions.

In view of the challenges related to inertia, short circuit level and network constraint issues, the project will demonstrate that the digital substation is capable of providing real-time and off-line diagnostic information. For example, it will enable new fault current phasor measurements to increase understanding of real fault current contributions from multiple locations. Furthermore, wide area control infrastructure functions such as regional data aggregation for robust measurements, and control logic acting on incoming aggregated signals form part of the control architecture.

The interaction between the substation and external systems is enabled by communication protocols. The use of internationally accepted non-proprietary standards enables modularity between the provision of data and the functions depending on them. The set of standards demonstrated in FITNESS for showcasing the full-scale digital substation solution from process bus level to the delivery of central applications and distributed control include:

- IEC 61850 8-1 Defines 'Station Bus' for information exchange within the substation, as shown in the structure in Figure 2 and GOOSE for control values and trip commands;
- IEEE C37.118-2011 standard for synchrophasors;
- IEC 60870-5-104 for SCADA data;
- Common Information Model (CIM) for consistency between referencing elements between substation and EMS/Wide Area Management System (WAMS);
- IEEE C37.111-2013 COMTRADE for transient data exchange.

FITNESS is intended to prove that the substation design will be an enabling technology for accelerating rollout of new monitoring, protection and control solutions, which are the focus of several on-going innovation projects.

2.3. Description of design of trials

There are four demonstration work packages in this project as described in this section and in further detail in Appendix C. Work package five is based on knowledge dissemination is described in detail in Section 5. These are further summarised in Figure 3.

WP1 Substation design will demonstrate the **design methodology**. This will focus on the processes for choice of suitable substation architecture through analysis of availability, maintainability, cost and environmental impact of different possible architectures. The outcome from this work package will determine the specification process, suitability and flexibility of the digital substation design for implementation in work package two and

three. This will enable fast asset replacement and modernisation of substation secondary systems with reduced outage durations.

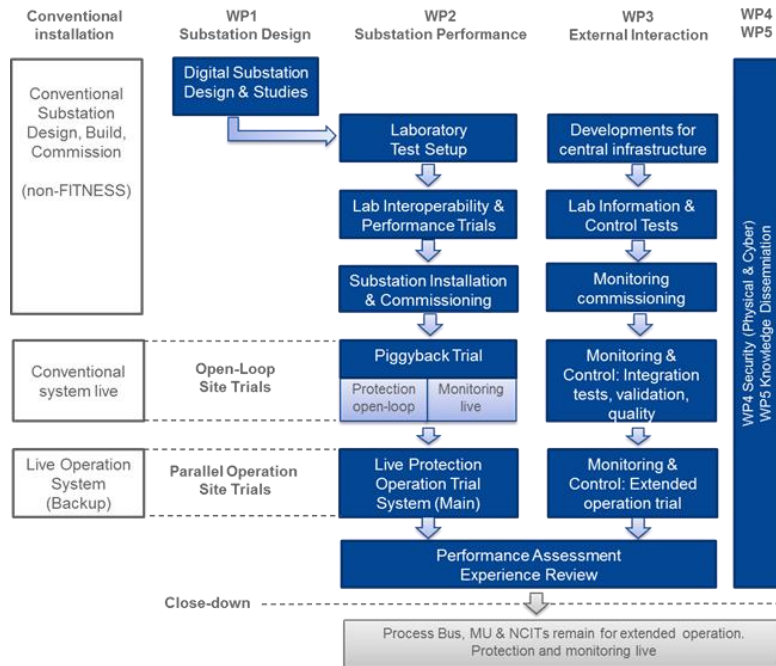

Figure 3 Demonstration Methods proving Substation Architecture and Integration

WP2 Substation performance will implement and demonstrate the **operation** of the multi-vendor digital substation in a staged approach: 1st stage: controlled laboratory tests, 2nd stage: substation trials with real data but disabled outputs parallel with conventional system and finally at the 3rd stage: live protection operation controlling switchgear. This will prove

- **Measurement quality:** Assessing consistency of digital measurement from NCITs and MUs against conventional analogue measurements over hardwired copper cables. This will prove accuracy of digitised data for monitoring, protection and control needs in a substation. It will also assess bandwidth requirements, dynamic range and reliability of digital measurements.
- **Interoperability** testing between multi-vendor equipment. This will prove that the NCITs-MUs, protection and tripping devices from different vendors can correctly interface in both offline and live environment. Interoperability will also be tested between equipment at non-conventional local and conventional remote end locations for differential and distance protection schemes. This outcome is important for business as usual roll out of digital substations which will adhere to the design diversity principle of transmission protection schemes and will optimise asset replacement. This is also required for maintaining reliability, and enabling a more flexible supply chain for digital substations in future.
- **Response time of live closed loop digital tripping** – Enabling fully digital protection and control over process bus from primary plant measurement to protection devices, and trip signals back to primary switchgear. The outcome of the trial is direct comparison of the digital tripping response time against conventional analogue systems during commissioning tests and live faults.
- **WP3 Substation-to-System Information & Control Integration** will demonstrate integration of external monitoring and control systems within the process bus architecture. This will enable easier and faster integration of low carbon technologies. The work package will demonstrate the new

architecture supports synchrophasor data streams, fault information (including synchronised snapshots) and fault location using continuous system NCIT data instead of dedicated CT/VTs as shown in

- Figure 4.
- The outcome will confirm that the digital substation can address information needs without loss of functionality to deliver and provide for the emerging requirements of dynamic monitoring and control. The project will demonstrate that the digital substation is an enabler and accelerator for rollout of innovative solutions involving wide area monitoring and control (see also **Appendix H**) including:
 - **VISOR-NIC⁴** FITNESS demonstrates data quality and equipment rollout process without outages and associated delays.
 - **EFCC-NIC⁵** FITNESS demonstrates the substation functions for data aggregation, reliability, quality, latency, as well as integration of a flexible control platform for EFCC into the substation environment.
 - **Smart Transmission Zone NIA⁶**. FITNESS demonstrates flexible implementation and low latency needed for stability control methods to relieve constraints.

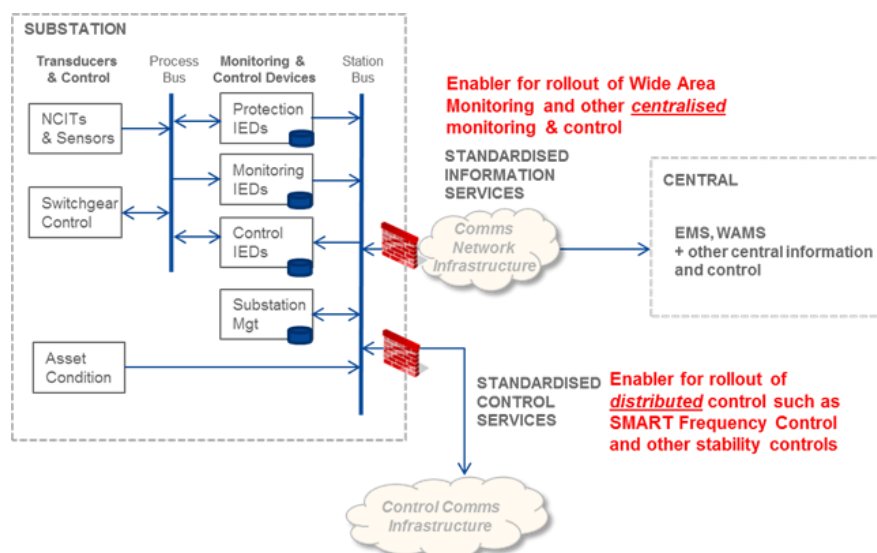

Figure 4 Substation Integration with External Systems

WP4 Security will demonstrate resilience to **security** threats. The demonstration will implement internationally accepted security practices within the digital substation architecture. It will develop a security risk assessment tool to assess devices connected within a substation for their susceptibility to cyber-attacks. Security issues with wide area monitoring and control will also be investigated. The outcome of this trial is to validate the security practices for remote access to the digital substation and for the transfer of wide area monitoring and control signals to and from the control centre.

2.4. Changes since Initial Screening Proposal

Since Initial Screening Proposal (ISP) stage, a greater emphasis has been placed on interoperability, including the involvement of two major OEMs, which will be of key

⁴ SPEN Visualisation of Real Time System Dynamics and Enhanced Monitoring (VISOR) <http://www.spenergynetworks.co.uk/pages/visor.asp>

⁵ National Grid EFCC Project: http://www.nationalgridconnecting.com/The_balance_of_power/

⁶ SPEN Smart Transmission Zone Project: http://www.smarternetworks.org/Files/Smart_Transmission_Zone_Proposal_130930121455.pdf

importance in proving the interoperability benefits and open aspects of the FITNESS solution.

Section 3: Project business case

3.1. Context

GB transmission network owners (TOs) are faced with growing challenges relating to increasing levels of low carbon generation connecting to the system. The widening gap between generation and transmission network capacity is in part a result of a bottleneck in outage planning and capital investment constraints. The Electricity Ten Year Statement (ETYS)⁷ 2014 describes dependence of network capability on the limitations of asset investment and constraint costs. It can be concluded that lack of network capacity and system unavailability restrict network capability and are thus potential barriers in the growth and connection of low carbon generation. To address the challenges facing TOs and to support the UK in meeting its carbon reduction targets, significant investment is required to improve network capacity and reduce constraints.

The UK Future Energy Scenarios (FES)⁸, Gone Green (GG), Slow Progression (SP), Low Carbon Life (LCL), (No Progression was not considered, as little innovation is predicted in this scenario) were used as well as the FITNESS uptake scenarios, Fully Digital (FD) and Partial Uptake (PU), to analyse the potential roll-out and uptake of the digital substation in GB. The projected number of digital bays in RIIO T2 in GB, for the different scenarios considered, is presented in Figure 5. Further detail can be found in **Appendix B**.

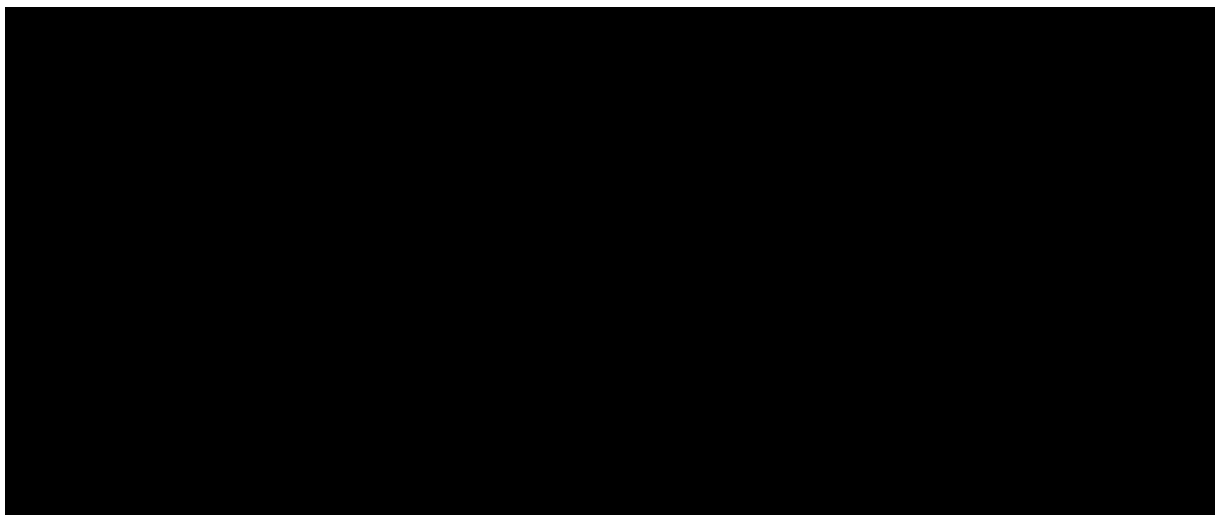

Figure 5 No. of Digital Bays and FES and Uptake Factors for RIIO T2 in GB

All of the FES scenarios show an increase in the level of constraint payments up to 2035, due to lack of available transmission capacity. To manage network constraints, new generators, a large proportion of which are low carbon, could be restricted from connecting to the network until extensive network reinforcement work is carried out. The balance between full unconstrained access with large up-front capital-investment, and a highly constrained network, deferring capital investment is struck by choosing the 'least regret' scenario in each regulatory investment period. FITNESS improves the balance by reducing the capital investment required for substation new build, and through the implementation

⁷ National Grid Electricity Ten Year Statement (ETYS) 2014: <http://www2.nationalgrid.com/UK/Industry-information/Future-of-Energy/Electricity-Ten-Year-Statement/>

⁸ UK Future Energy Scenarios (FES) - <http://www2.nationalgrid.com/uk/industry-information/future-of-energy/future-energy-scenarios/>

of a more flexible infrastructure that reduces outage time required for secondary system modernisation and replacement.

FITNESS proposes an alternative to the conventional substation design, whereby the reinforcement process can be accelerated, reducing outages and increasing build rate, as well as improving availability in operations. The controllability of the assets also enables reduced constraints with wide area monitoring and control infrastructure for 'connect and manage' solutions. Furthermore, the improved observability of hybrid circuits reduces fault-related outage time by differentiating the actions applied when the fault is overhead or underground. Figure 6 compares network capacity, installed generation capacity and constraint costs against the projected FITNESS constraint costs, and improved capacity realised through FITNESS.

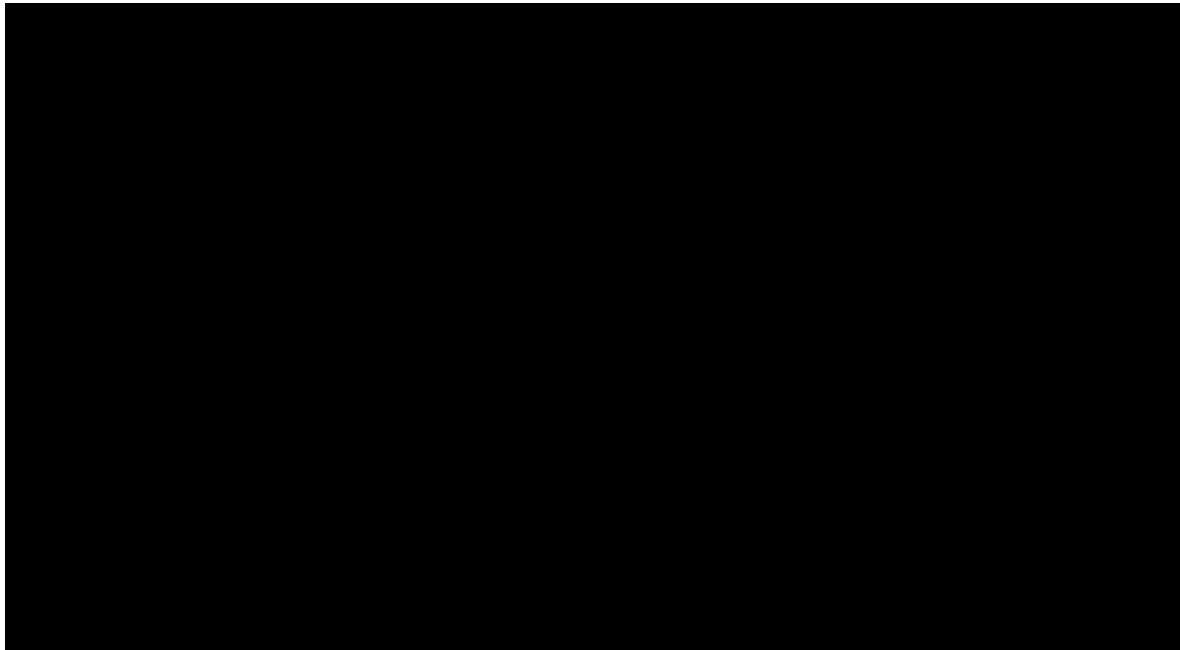

Figure 6 Constraints and Capacity Requirements

The successful deployment and implementation of FITNESS is expected to lead to total benefits between RIIO T2 to T5, depending on FES and rate of uptake of the digital substation by GB TOs, in the range of:

- 10% of substation costs equating to **£572m-£858m**;
- 4.75% of constraint payments equating **£260m-£592m**.

The sources of cost figures quoted throughout this section are explained in more depth in **Appendix B** and **Appendix G**.

3.2. Overview of the business case for FITNESS

In summary, the business case for FITNESS is built on the following benefits offered by deployment of the digital substation and technologies:

- **Substation Cost** – Reduction in load and non-load related asset investment.
- **Operational Flexibility** – Improved operational flexibility for non-load related work on secondary system. Improved system visibility, diagnostics and operation through provision of high quality current and voltage measurements. Further benefits in dynamic constraints and infrastructure to apply new control measures outlined in Section 4, but are not included in the business case.
- **Outages** – Reduction in planned outages, network constraints and the associated grid services costs.

- **Safety** – replacement of conventional CTs with NCITs eliminates risk of explosion, and reduces risk to personnel and equipment. Digitisation of all data at source and fibre optic communication results in greatly reduced copper use.

3.3. Scottish Power Transmission business

Reduction in substation costs

The current practice followed by TOs for substation design, replacement and refurbishment is the most efficient practice which has evolved over years through experience and best supply chain solutions available to utilities. Further improvements to substations in terms of reducing costs require a step change in design.

Substation costs that are related to substation functionality and operation include primary and secondary equipment, cabling, and engineering and commissioning. Engineering and commissioning costs are reduced by maximising the amount of relay testing at the factory and minimising the amount of testing required on-site. Substation costs related to civil works, project management and design in new build or replacements require large investment, can be reduced by smaller physical size, fewer supporting structures, smaller cable ducting and reducing engineering effort. A significant contribution to the minimisation of these costs is through standardisation of design, equipment and procedures. Some costs are outside of the TO’s influence, such as equipment costs (e.g. transformers, switchgear), which are driven by market prices and framework agreements.

Figure 7 highlights the projected reduction in substation bay costs for a conventional substation design, a FITNESS replacement of an existing conventional substation, FITNESS new build, and a FITNESS digital-to-digital replacement (from 2037 onwards, after 15 years of digital substation lifecycle), based on information from SPTs design, planning and procurement departments as well as manufacturers.

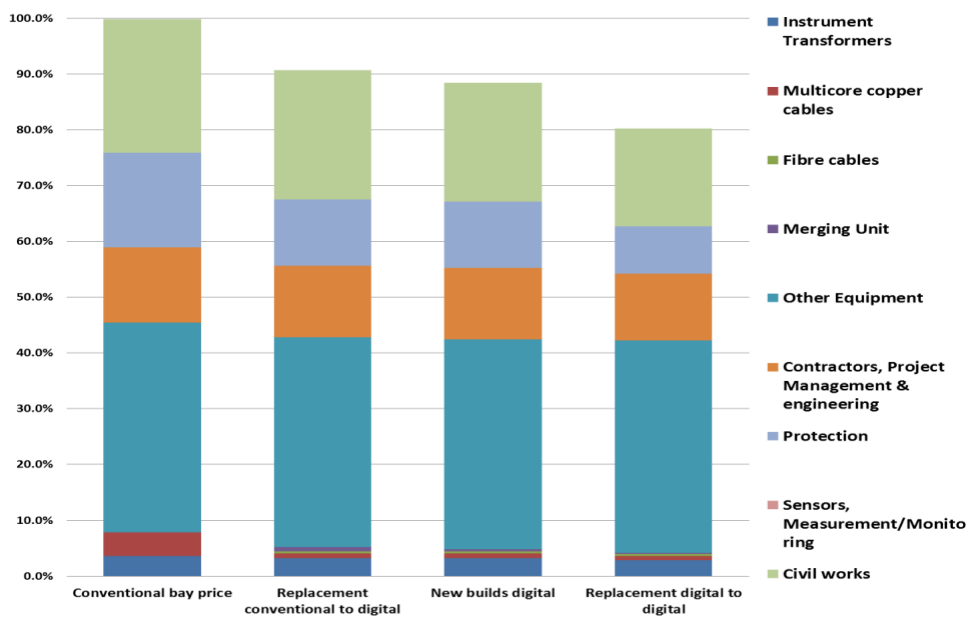

Figure 7 Comparison of Substation Bay Costs for Conventional and Digital Substation

To optimise upfront CAPEX investment it is also important to consider costs associated with risk, which include safety during testing and commissioning and Energy Not Supplied (ENS) penalty costs. These costs can be minimised by improving substation safety and reducing outages times.

There is a clear business case for FITNESS, as it can realise a reduction in substations costs through:

- **Reduced civil works** – NCITs can be mounted on the same structure as other primary equipment such as circuit breakers or disconnectors, thus avoiding the need for additional foundations and support structures.
- **Reduced ducting** – reduction in copper wiring resulting in reduction in trenching and ducting.
- **Reduced substation footprint** – smaller protection and control cubicles resulting in smaller substation control room, as well as reduced footprint required for NCITs as opposed to conventional CTs and VTs.
- **Reduced wiring** – copper cabling is greatly reduced, with optical fibre being used instead.
- **Reduced engineering and commissioning time** for planning, cabling and testing - much of the construction, interconnections, testing can be carried out off-site at the manufacturers’ facilities.
- **Reduced on-site time** – with FITNESS substation design, on-site time for replacement work is greatly reduced as much of the testing is pre-delivery.

The benefits will be discussed further in Section 4: Benefits, timeliness, and partners.

Improved operational flexibility

FITNESS addresses a number of areas where operational costs can be reduced through reduction in the number and length of outages. Ofgem proposes that TOs should be provided with a marginal reward/penalty for over/under performing against target levels of Energy Not Supplied (ENS). ENS is a function of outage time, and a reduction in number and length of outages will enable a reduction in the operational risk and costs associated with ENS.

Cost and time savings on-site are substantial with the more flexible digital design, as the majority of testing and commissioning can be carried out in the factory. Technical issues or challenges that arise during factory testing and commissioning can be resolved much more economically than those that arise on-site. Outage requirements per bay for different types of substation works in both the conventional and FITNESS substation designs are compared in **Appendix G**.

The FITNESS substation design also enables savings in operational practice and procedures. Traditionally, if a protection device fails, the primary plant may operate under depletion i.e. with non-redundant protection for no more than two hours. After two hours, the primary plant must then be taken out of service, resulting in an outage. In conventional practice, to avoid outage, protection device failure requires immediate and urgent response to return the system to normal service. With the FITNESS substation design, hot-standby reserve protection, as discussed in Section 2, can be used to take over functions of the failed device, thus avoiding the need for resorting to a system depletion or outage. The failed device can be replaced through remote access and configuration change, and does not require a change to wired connections to primary plant, meaning that the primary plant can remain in service throughout.

It is assumed that the mean time between failures (MTBF) of conventional protection devices is typically 100 years, and the time to restore is 24 hours. Each bay has two main protection systems, so refurbishing 200 bays would typically mitigate the consequences of four such failures per year, each requiring 24 hours outage. In the longer term, applying

the same philosophy throughout the SPT network of approximately 800 bays would be expected to save 24 unplanned outages, each typically of 24 hours in duration.⁹

Other benefits

In addition to the business case elements described above, there are other areas of risk management that are not easily quantified, but add to the project business case. These include:

- **Improved substation safety** - Risk to life of working with CT secondary circuits; while the hazard is mitigated by design and working practises, it would be eliminated through replacement of conventional CTs with NCITs.
- **Substation environmental and carbon impact** of use of copper, oil and gas in substations. Oil and gas usage is reduced by 80% through replacement of conventional instrument transformers with NCITs, and copper usage is greatly reduced by replacement with optical fibre. Thermal losses associated with conventional CTs and secondary wiring will also be reduced through replacement with NCITs.
- **Outage scheduling**. Outages are scheduled by the SO up to seven years in advance. Over-run of one outage for maintenance can have a significant knock-on effect on others, and there is a risk that the schedule for modernisations and new connections is extended, resulting in new connections being substantially delayed, and modernisation of assets delayed by months or years, resulting in increased failure rates and delays to circuit uprating leading to constraints. Requiring shorter outage windows significantly reduces the risk of over-run, as the scheme can be fully tested prior to site work starting, and leads to increased flexibility.

3.4. System Operator and Customer: Constraint Payments, Balancing and Grid Services

Network constraints result in increased costs to consumers and reduce access to the grid for generators, particularly for wind farms. In order to reduce network constraints and constraint payments, new generators can be discouraged from connecting to the network until extensive reinforcement work is carried out. This will however have a detrimental effect to the UK in meeting its carbon reduction targets.

While constraint and balancing costs are borne by the system operator (SO) rather than the TO, it is recognised that these costs affect UK customers, and is therefore an important consideration. The constraint and balancing payments included in costs associated with network balancing services account for approximately 1% of customers' bills.¹⁰ Reduction of network constraints through outage-based constraint reduction reduces the constraint and balancing cost. Further improvements are made possible by control-related constraint reduction.

There is some uncertainty around future scenarios. Capital-intensive transmission reinforcement would lead to a relatively low level of constraint costs, while lower investment in reinforcements leads to higher constraint costs. Benefits of FITNESS will accrue in either case. If a high investment/low constraint approach is taken, the benefits of the capital costs will be more significant, and if a more constrained approach is taken, outage reduction and flexibility for control has greater significance.

⁹ Tournier J.C, Werner T., "A Quantitative Evaluation of IEC 61850 Process Bus Architectures", IEEE PES General Meeting, Minneapolis, US, 2010

¹⁰ National Grid March 2014 Monthly Balancing Services Summary FY2013/14

3.5. Summary of Financial Benefits

FITNESS will achieve significant long run financial savings in the operational practices of transmission substations, as well as savings in CAPEX costs from digital substation architecture and design. The cumulative non-discounted financial benefits are projected over the last two years of RIIO T1, T2 and RIIO T3, T4 and the first four years of RIIO T5 (2020 – 2050). The range of benefits depends on six different scenarios subject to the UK FES, as well as the predicted uptake of the FITNESS solution, which is subject to the level of success of the demonstration. The financial benefits have been summarised to cover the five key areas where savings are realised in the digital substation. The assumptions used to calculate the financial savings are discussed in more detail in **Appendix B**. All projected benefits between 2020 and 2050 are given in non-discounted nominal terms.

The digital substation design will enable an initial reduction of 12% and 9.4% in the cost of bay new builds and bay replacements respectively. By 2037, we expect that the digital substation will be the default standard, therefore equipment price will drop while conventional becomes expensive or unavailable. For the purpose of analysis, we assume a 20% reduction in substation bay cost as compared to conventional by 2037. The non-discounted net financial savings in substation costs will realise a maximum value in the GG, FD scenario of **£858m**, and a minimum saving of **£572m** in the LCL, PU scenario. Under the same scenarios, our incremental assessment (assuming delayed and reduced adoption of digital substations, described in Appendix B) estimates the incremental benefits in substation costs accruing only to FITNESS are between **+£273m to +£160m**.

The total non-discounted savings that could be realised from digital substation operation and maintenance due to the reduced modernisation costs, reduced risk of incurring costs from ENS payments, and the reduction in time spent on site by engineers in order to change protection settings will be a maximum of **£67m** in the GG FD scenario, and a minimum of **£45m** in the LCL PU scenario. The incremental operation and maintenance savings are in the region of **+£25m to +£14m**.

The total savings in constraint payments due to reduced or avoided planned outage duration for replacement and modernisation works will be a maximum non-discounted saving of **£592m** in the GG FD scenario. In the constraint cost projections provided by the FES, the LCL scenario incurs higher constraint costs than SP. Therefore, in the analysis the minimum constraint cost saving from FITNESS will be the SP PU Scenario, returning a non-discounted value of **£260m** over the investment periods from 2020 – 2050. The incremental constraint payment savings are in the region of **+£293m to +£115m**.

The safety benefits from FITNESS have been quantified as a risk aversion, rather than a direct financial saving and are therefore not quantified as financial benefits in this section. The improved safety is due to safer equipment through electrical isolation provided by fibre optic interfaces, the use of NCITs, which are often intrinsically isolated, and a reduction in the time engineers need to spend on site in order to complete new builds, replacements and modernisations.

For total CO₂ reduction realised through a fall in potential constraints on wind generation, the maximum financial savings to society for the GG FD Scenario is **£500m**, whilst the minimum potential saving is **£200m**. The total financial savings in use of copper, based on the annual fixed costs per tonne of CO₂, will be **£3.3m** for GG FD, and **£2m** for LCL PU. The incremental carbon benefits are **+234m to +100m**. The assumptions for CO₂ caused by a reduction in wind constraints and use of copper are described in **Appendix B**.

Section 4: Benefits, timeliness, and partners

(a) Accelerates the development of a low carbon energy sector and/or delivers environmental benefits whilst having the potential to deliver net financial benefits to future and/or existing Customers

SPEN is supportive of the UK's transition to a low carbon economy by enabling best practice throughout its transmission system. FITNESS will demonstrate methods to increase the efficiency and reliability of the network, with a direct impact on the Carbon Plan in supporting the integration of more low carbon generation, particularly wind: "paving the way towards a 'smarter' electricity grid in the UK, which will increase the efficiency and reliability of the network, ... and support integration of more local and wind-powered generation."¹¹

Outages lead to network constraints and reduce access to the grid for low carbon generators. The National Grid Monthly Balancing Services Summary (MBSS 2014/15)¹² shows £62.56m in constraint payments to wind generators, which is 60% of constraint costs paid by National Grid, and 21% of the net constraint/rebalancing costs. FITNESS will increase the availability of the network to wind generators, through

- Reducing outage time for carrying out substation replacement and modernisation
- Enabling greater use of the network through improved observability and control.

The projected system availability improvements quantified in Section 3 and Appendix B translate into a carbon saving of between 40.5 and 129.5 thousand tonnes of CO₂ per year by 2030, depending on level of uptake, and based on increased amount of wind generated. These savings in CO₂ emissions correspond to a societal financial saving of between £3.3m and £10.5m per year by 2030 (according to UK government projection¹³).

The digital substation design leads to easier integration of infrastructure to provide monitoring and control functions that support integration of low carbon energy sources. Equipment such as Phasor Measurement Units (PMUs) and phasor-enabled controllers are more easily integrated into the digital substation without hardwiring, reducing the need for planned outages. Furthermore, the use of NCITs facilitates improved accuracy and dynamic response, and distributed sensors improve the observability and aggregation required for robust measurement infrastructure for wide area control.

The FITNESS project enables and accelerates the roll-out of innovation that depends on phasor-based measurement and control. Though not included in the direct benefit calculations, the project is designed to demonstrate supporting infrastructure for other innovations. Examples of innovations that could apply and benefit from the FITNESS digital substation infrastructure include (see Appendix H):

- National Grid EFCC¹⁴: Enabling fast frequency reserve, potentially saving £200M/year compared with base case of conventional reserve

¹¹ Carbon Plan: https://www.gov.uk/government/uploads/system/uploads/attachment_data/file/47621/1358-the-carbon-plan.pdf

¹² National Grid Monthly Balancing Services Summary (MBSS March 2015, FY2014-2015): <http://www2.nationalgrid.com/UK/Industry-information/Electricity-transmission-operational-data/Report-explorer/Services-Reports/>

¹³ UK Government: traded carbon price <https://www.gov.uk/carbon-valuation>

¹⁴ EFCC NIC project (a.k.a. SMART Frequency Control) http://www.nationalgridconnecting.com/The_balance_of_power/

- National Grid Humber SmartZone¹⁵: Pilot project on wide area control quoting around 5% circuit capacity increase, 10% constraint cost relief
- Smart Transmission Zone: Possible 6% increase in boundary transfer by wide area control of HVDC¹⁶; study also showed further stability constraint relief options
- Angle Constraint Active Management (ACAM): Shows potential to raise wind energy generation in a 33kV network by around 44% by phasor-based control.¹⁷
- Hybrid Line Protection by Rogowski Coil: FITNESS improves on the proposed cable-end monitoring by greatly simplifying the sensor deployment through passive distributed sensors for all cable sections on a single fibre.

The ability to increase constrained boundaries in transmission or distribution circuits enables more generation to be connected without the cost and delays in adding new network assets. This encourages connection of new low carbon generators, facilitating the Carbon Plan, supporting the development of electricity networks and minimising unnecessary barriers and potential delays in connecting new energy infrastructure.

Analysis until 2050 forecasts that FITNESS would enable an average reduction of at least 3.3% and 5.0% in network constraints due to outages, based on the uptake scenarios (not including control-based constraint relief). According to the MBSS, payments totalling £62.6m were made in FY2014/15 to manage constraints. Using an average price of action of £50/MWh, we can approximate that 1,252,000 MWh of wind generation were constrained in this year. With network constraints, and constraint payments expected to peak at approximately £490m in the GG Scenario in 2021, as highlighted in the FES, 5% constraint relief would equate to £24.5m savings in SO costs. Based on the expected constraints in FES scenarios, and the level of uptake, FITNESS could release between cumulative 70 MW to 200 MW per year in capacity constraints over RIIO T2 and RIIO T5. The cost to increase capacity by the same amount using conventional strategies would be between £13.9m and £205.9m at £34k/MW further explained in Appendix G.3.

An example of FITNESS being an enabler for monitoring and control technology is illustrated by VISOR, an NIC funded project. Ten PMU/WMU units needed to be installed on the network, with each installation requiring an outage of 1-2 days. This took almost two years to complete, incurring additional installation costs, a need for planned outages, network constraints and delaying the release of capacity and potential benefits. With roll-out of the FITNESS substation design, all ten of the PMU/WMUs required for VISOR could be installed within a day, subject to site access and engineer availability.

FITNESS provides a number of environmental benefits relating to connection and access to the grid for low carbon generation, as well as to the design and lifecycle of substations. A 10% reduction in substation footprint is realised through space savings in the relay house and in the switchyard. NCITs, which are smaller and lighter than conventional CTs and VTs, can share structures with existing primary plant, while conventional CTs and VTs require a dedicate structure and foundation.

An 80% reduction in the use of copper in digital substations compared to a conventional substation is realised by replacing copper cables with fibre optic communications. This not

¹⁵ Humber Smartzone Pilot Project http://www.smarternetworks.org/NIA_PEA_PDF/NIA_NGET0056_4822.pdf

¹⁶ King, R. et al: "HVDC Stability Control using Wide Area Measurements for Optimising Transmission Boundary Transfer", IET ACDC conference, Birmingham, Feb 2015

¹⁷ Wang D. et al: "Quantifying benefit of angle constraint active management on 33kV distribution network", CIRED, Lyon, June 2015

only realises environmental benefits associated with reduced copper usage, but shortens installation and retrofit times and enables complete system supervision, reducing maintenance requirements. In the GG FD scenario this corresponds to a saving of 25,000 tonnes of CO₂, corresponding to a societal financial saving of approximately £3.3m across RIIO T2 to T5. In the LCL PU Scenario, the reduction in copper usage relates to a saving of 14,000 tonnes of CO₂, resulting in a £2m saving to society. A reduction in the use of oil and gas is realised due to replacement of conventional CTs and VTs, with NCITs. NCITs which use optical, capacitive or Rogowski principles have greatly reduced use of oil and gas when compared with conventional instrument transformers with electromagnetic cores. The required civil works involved with foundations, mountings, trenching and laying of copper cables, as well as civil works associated with the substation building size will also be reduced as shown in Figure 8.

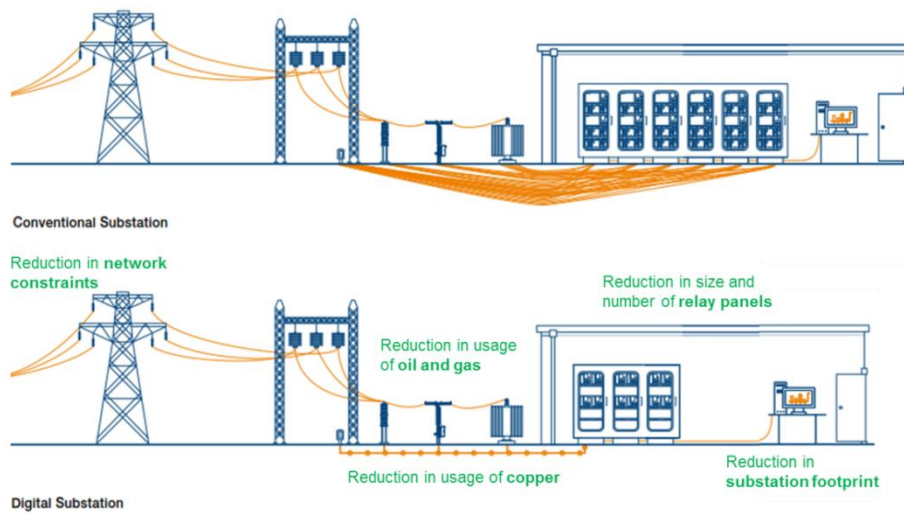

Figure 8 Summary of Environmental Benefits

Dependence on carbon and energy intensive production of material as well as detailed reductions in land and material usage was fully analysed in the **Life Cycle Assessment** that was carried out comparing digital and conventional substations.

The financial benefits have been projected, dependent upon the success of the FITNESS demonstration, as well as the subsequent Future Energy Scenario’s produced by National Grid. The maximum cumulative financial benefits between 2020 and 2050 are presented in Figure 9. Section 3 and **Appendix B** discuss the financial benefits in more detail.

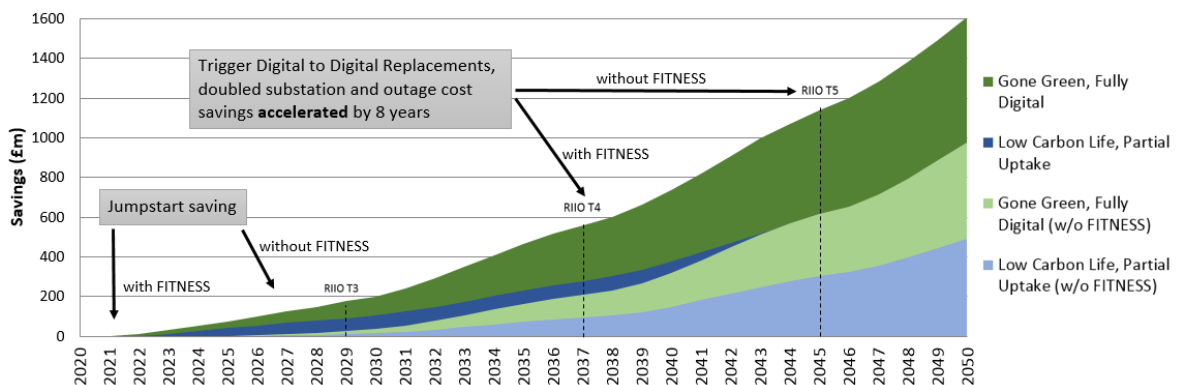

Figure 9 Cumulative Savings in FITNESS Scenarios, with and without FITNESS

(b) Provides value for money to gas/electricity distribution/transmission Customers

FITNESS provides value for money for transmission and distribution customers:

- Benefits in terms of network cost reduction and to GB SO customers
- Competitively costed project, with strong commitment from the supply chain
- Facilitates efficient rollout of other GB innovation projects

The digital substation demonstrated by FITNESS will benefit customers, as reduced substation costs, reduced outages and reduced constraints by monitoring and control will influence the TO and GB SO costs, which ultimately reduces customer bills. Risks of ENS penalty costs are also reduced by the outage time reduction and greater observability of the system. Analysis carried out indicates savings of approximately 9.4% in terms of substation capital costs, and approximately 33.4% of outage costs and operational savings, as well as cheaper overall energy through increased low carbon generation.

The SO uses a number of balancing services to operate the transmission system in an efficient, economic and co-ordinated manner ensuring that supply of energy matches demand. When the SO requires a generator to reduce output due to a network constraint, energy is purchased from the balancing market to supply the deficit. FITNESS will benefit the SO through a reduction in network constraints resulting from fewer and shorter outages, which will directly reduce the constraint payments made by the SO to generators, and will indirectly reduce the other balancing services used by the SO in managing the network.

Energy bills are made up of a number of elements, such as the wholesale costs, supplier operating costs, and network costs. Balancing costs are currently a relatively small element of consumer bills (1%¹⁸). Constraint and balancing payments are projected to increase significantly in the ETYS 2014, and these costs will make up an increasing proportion of the consumers bill. FITNESS, through the methods described throughout this proposal, will enable a reduction in both the transmission network costs and balancing services components of the consumers' energy bills. Transferring the learning to the distribution domain would further decrease consumer energy bills.

The gap between developing and implementing new technology is an obstacle to deployment in utilities throughout the world. Demonstration projects are therefore essential for building the knowledge and confidence required by GB TOs (and DNOs) to deploy new technology without reducing the reliability of the network. Without full confidence in non-conventional technology and innovative substation automation solutions, and established procedures, deployment will be slow and piecemeal.

While parts of the IEC 61850 standard that define communication protocols have been adopted widely, the IEC 61850 9-2 standard (Process Bus), which involves an entirely different approach to substation architecture, design and construction, has not yet been adopted in the industry. The reluctance relates to uncertainty over the technical maturity, performance, reliability and robustness because of the lack of industry experience.

The proposed FITNESS demonstration of a full IEC 61850 digital substation with advanced, novel functions in a transmission connected substation, and proving the full value chain

¹⁸ <http://www2.nationalgrid.com/UK/Our-company/Electricity/Balancing-the-network/>

from process and station level through to the utilities central systems, is therefore justified in both scale and cost. The learning gained will accelerate uptake by providing construction, engineers, planners and operators with confidence in the new systems, leading to quicker deployment into business-as-usual, while reducing costs and risks associated with IEC 61850 technology and standards.

SPEN will follow SPTs procurement and legal policies to ensure contractual agreements between partners are in place, while ensuring established processes are followed and project milestone payments are aligned with project plan and SDRCs. Cost estimates from various partners were reviewed, to ensure FITNESS benefits from discounted rates, the right levels of risk mitigation to avoid cost overruns and in kind contributions from partners in terms of material and labour. SPEN has also encouraged UK SMEs e.g. Synaptec to bring to market their innovative technologies and ideas through FITNESS. Synaptec will benefit from project FITNESS by working with OEMs (ALSTOM and ABB) in realising potential applications for distributed sensing technology.

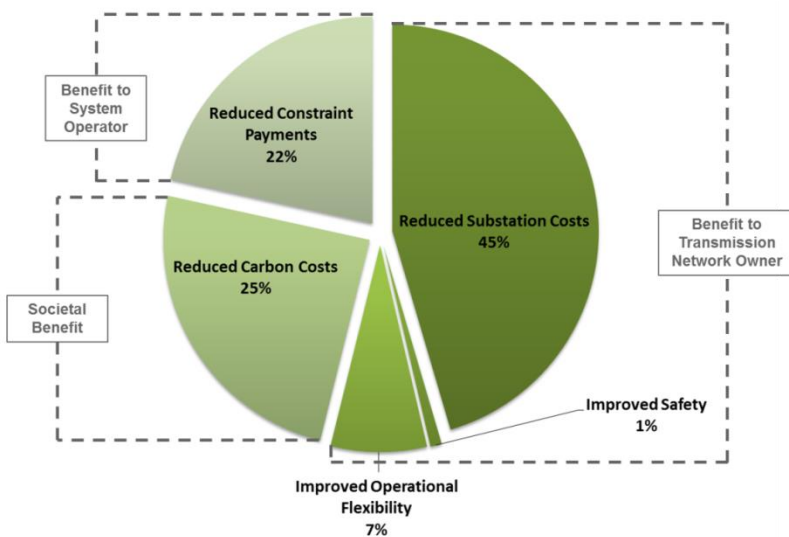

Figure 10 Breakdown of Potential Benefits

FITNESS also facilitates the business-as-usual rollout of several innovation projects, as described in Appendix H. The infrastructure in FITNESS enables greater value to be derived from a large body of innovation work funded by GB customers.

A breakdown of the potential benefits realised and the proportion of these benefits that are accrued by the TO, SO and society as a whole, is illustrated in Figure 10

(d) Is innovative (i.e. not business-as-usual) and has an unproven business case where the innovation risk warrants a limited Development or Demonstration Project to demonstrate its effectiveness

The final report for the CEN/CENELEC/ETSI Joint Working Group on Standards for Smart Grids states: "Standardization of smart grids is not — business-as-usual. The huge number of stakeholders, the necessary speed, the many international activities and the still changing solutions make it a difficult task for the European Standardization Organizations (ESOs)."¹⁹ In this context FITNESS is considered to be an important step in the journey to business-as-usual.

Key areas of innovation in FITNESS are:

¹⁹ CEN/CENELEC/ETSI Final Report Standards for Smart Grids: http://www.etsi.org/WebSite/document/Report_CENCLCETSI_Standards_Smart%20Grids.pdf

1. **Integrated system of protection, monitoring and control** is globally innovative. Previous projects have dealt with individual subsystems such as non-conventional instrument transformers (NCITs) and protection.
2. **Bus architecture** for measured sampled values (SV) published to all secondary devices, extending beyond AS3 (Architecture of Substation Secondary Systems)²⁰ project trials (point-to-point connections).
3. **Multi-vendor interoperability** has not been proven in a live substation. This is critical step for proving standardisation and progressing to business-as-usual.
4. **Distributed optical sensing**, innovation in first-time (1) sensor technology development (2) integration with substation information (3) application use cases.
5. **Non-conventional voltage transformers (NCVTs)**; first two commercial product deployments of novel NCVTs are in Scottish Power Energy Networks (SPEN) and RTE France.
6. **Information co-ordination:**
 - First proof of NCITs, through the information infrastructure to existing and emerging application requirements;
 - First demonstration of NCITs as single unified data source to replace separate transformers for protection, measurement and power quality (PQ);
 - Greatly improved access to information sources without CT/VT connections;
 - New information services with greatly reduced substation instrumentation e.g. system fault current map, harmonics map, hybrid line fault location;
 - End to end integration of substation and central system applications, to increase visibility and situational awareness.
7. **Wide Area Control (WAC) infrastructure** first demonstration of standardised substation implementation of flexible wide area control capability.

FITNESS builds on work done under the AS3 IFI project. AS3 delivered a review of the substation life cycle issues, a new standard architecture for substation secondary systems and draft specifications for system configuration and MUs. AS3 also completed four piggy-back trials which demonstrated and proved the concept and benefits of using IEC 61850 9-2 process bus technologies. The AS3 piggy-back trials were performed in a live substation, however the IED outputs were disabled (i.e. the protection was not allowed to initiate tripping), the process bus was a simple point to point connection from a MU to a single IED and the trials did not demonstrate interoperability or additional monitoring and control functions.

In the proposed FITNESS demonstration, the IEC 61850 architecture and associated equipment will be operated live in parallel with the existing analogue protection equipment. The loop from the IED outputs to the circuit breaker trip coils will be closed with tripping signals from the IED sent via a GOOSE messaging to the Switchgear Control Unit (SCU), also using the process bus. This makes full use of the IEC 61850 architecture and has not been done in GB before.

The FITNESS demonstration will also prove the true process bus concept of the architecture. More than one MU will publish SVs to the IEC 61850 9-2 process bus to which more than one IED will be connected. Each IED will subscribe to SVs from the relevant MU. The IEDs connected to the process bus will include protection IEDs as well as PQ and Wide Area Monitoring (WAM) devices incorporating PMUs. The MUs and IEDs will be from different manufacturers and interoperability will therefore be clearly demonstrated by FITNESS, paving the way for business-as-usual roll-out.

²⁰ National Grid AS3 Project: <http://www.smarternetworks.org/Project.aspx?ProjectID=684>

Wide area monitoring and control equipment is an essential requirement for the roll-out of the VISOR and EFCC NIC project. FITNESS is the first GB trial of PMUs connecting to the process bus, rather than via hardwired signals. Furthermore, the substation infrastructure of the EFCC design for control will be applied in FITNESS, as well as other wide area control methods. This demonstrates that a standardised implementation approach can be applied within a digital substation. This level of integration has not yet been tried in a live substation environment in GB. Similarly, the use of disturbance and fault recording or power quality data from process bus data has not been trialled in GB.

The IEC 61850 9-2 process bus architecture facilitates the implementation of the novel hot-standby protection scheme discussed in Section 2. In this scheme, as soon as the failure of a protection IED is detected, the assigned hot-standby protection IED will switch to a protection setting group with the same settings as the failed IED, subscribe to the SVs associated with the failed IED and when required publish trip GOOSE messages to the associated SCU. The hot-standby protection IED automatically acts as the replacement protection, without need for an outage or human intervention. This novel process involves technical complexity and needs to be demonstrated before it can be implemented as business-as-usual.

To facilitate the evolution of conventional substations to full digital substations on a bay by bay basis, there will be several cases where a fully digital bay in a digital substation will be connected to a bay in another conventional substation. In these cases the line differential protection will have a fully digital protection IED at one end (with process bus interface to a MU or NCIT) and a conventional protection IED (connected to conventional CTs) at the other end. FITNESS will also prove this aspect of interoperability.

Other innovative aspects of the FITNESS demonstration include:

- Non-conventional VTs have not been used in GB. The application of NCITs in a full digital substation and their durability when exposed to the harsh environmental conditions, transient currents and voltages and mechanical stresses in a live substation will be proven through FITNESS. Although optical CTs have been trialled in GB in the past, their output has never been integrated in IEC 61850 9-2 format into a complete digital substation solution.
- Distributed sensor technology which allows current and voltage measurements over long distances (~100km) without the need for auxiliary power and which facilitates multiple measurements to be carried over a single optical fibre is another unproven technology in GB that will also be proved during FITNESS.
- Harmonics Mapping and Harmonics Source Location - Based on the improved data quality obtainable from NCITs which have a wide dynamic range and a high measurement bandwidth, PQ monitoring equipment will be used to develop harmonics mapping and harmonics source location for the first time in GB.

Power system protection dependability (systems operate correctly for in-zone faults) and security (systems do not operate for out-of-zone faults) is of paramount importance in transmission networks. Protection systems are critical for ensuring the safety of network operations, personnel and the general public. If a protection system does not operate within a specified time or fails to detect a fault on the network, assets are at risk of damage and people at risk of severe injury. As with the introduction of any new technology, operations and maintenance staff will require training in new practises associated with a fully digital substation. There is a risk of unintended protection IED operations and consequent circuit outages during the familiarisation and learning period.

Although IEC 61850 9-2 products and systems are commercially available, they are not widely utilised in standard practices. The risks involved in deploying such a solution require a demonstration project to prove technical acceptability before integration into business-as-usual. The parallel deployment of conventional and non-conventional technology for risk mitigation and to undertake a comparative analysis adds expense to a bay modernisation. Under business-as-usual, lowest-cost options must be deployed, and therefore this additional expense cannot be justified. Parallel deployment is an important risk mitigation stage on the route to live deployment.

If, during the demonstration of this novel technology, a protection system trips when not required to, this may lead to the system being constrained unnecessarily and energy may not be supplied, this can lead to financial losses and negative reputational impact.

GB TOs are fully aware of their responsibilities as per the NETS SQSS and thus any step change and/or conceptual change in the protection system, even with large perceived benefits, will need to be well assessed, trialled and proved before it is implemented in a systematic controlled manner.

(e). How Project Partners have been identified and selected, the process that has been followed and the rationale for selecting Project Participants and ideas for the Projects;

An extensive internal and external stakeholder engagement for selecting FITNESS for the 2015 RIIO NIC was carried out. FITNESS was conceptualised by analysing the key areas for innovation requirements in SPT. SPTs Innovation Strategy review (2014) identified interoperability and intelligence as key areas for innovation.

The idea of moving to a fully digital substation design concept and the feasibility and necessity of undertaking a demonstration project to prove concept and gain necessary experience in RIIO T1 to enable planning for RIIO T2 was discussed with the Network Planning and Regulation team and analysed by SPT's Engineering Services and Design team. The project scope was thus established to include IEC 61850 9-2 Process Bus architecture, integration of PAC and WAMS concepts and integration with central systems for seamless transition after proof of concept to business-as-usual. The scope and innovation components were then verified by engaging with GB TOs (NGET and SSE) and international TOs (RTE). A brief scope was sent to suppliers to gauge interest in the supply chain for innovation in substation design. All major suppliers e.g. ALSTOM, ABB, SIEMENS, GE, SEL, ZIV, Ingeteam and Alcatel-Lucent proved willing to participate in the project and offered help in identifying key innovation components.

A two staged internal review process was staged undertaken in February 2015 to identify the probable most promising innovation projects from a list of ideas for 2015 NIC submission. FITNESS was selected after internal evaluation for innovation and benefits for submission under the SPT Licensee.

A wider stakeholder engagement was undertaken at the PAC World Conference in June 2015, where 150 guests were in attendance, to determine interest in FITNESS from key industry players. The results of the stakeholder engagement survey are presented in **Appendix D**.

The FITNESS proposal development team undertook a detailed partner selection process to select project partners based on quality of technical solutions and innovation offered, previous experience and cost for delivery through a two-stage selection process:

1. All interested suppliers submitted a proposal based on a project scope provided by SPEN to highlight compliance with technology requirements, and contribution to key areas of innovation. After careful evaluation of all proposals from ALSTOM, ABB, SIEMENS, SEL, ZIV, Ingeteam and Alcatel-Lucent, five of suppliers were selected for the second stage of the proposal review.
2. All suppliers completed the partner selection criteria form supplied by SPEN, which were then assessed against an evaluation criteria and weightings. The results of which are presented in **Appendix D**.

(f) Relevance and timing

Future Energy Scenario and UK Carbon Plan - Drivers for substation Design

If the UK is to meet its carbon reduction targets, the percentage of low carbon generation in the total generation mix needs to continue growing. To accommodate an increasing penetration of low carbon generation it is necessary that system operability is improved. System operability is the ability to maintain system stability and asset use within pre-defined limits, in a safe, economical and sustainable manner. This is challenging, as the system becomes more dynamic with reduced inertia and intermittent generation.

FITNESS will significantly reduce both the number and duration of planned outages, and thus network constraints. The implementation of high accuracy wide area monitoring (WAM) facilitated by the use of NCITs and distributed sensors will allow the transmission system to be operated closer to its operability limits. A less-constrained transmission network and one with increased operability limits will facilitate the connection and effective management of low carbon generation.

The System Operability Framework (SOF)²¹ states: "Improving the study capability is one of the key recommendations of SOF in many topics. This includes the use of new tools such as advanced monitoring using PMU, new modelling tools for transmission and distribution interface issues to ensure better assessment of the impact of change in energy landscape in the whole system."

FITNESS will demonstrate the accessibility of accurate wide area monitoring information made readily available by the IEC 61850 architecture and the use of NCITs and PMUs/WMUs. This will have a positive impact on improving system capability.

GB TO business model and price control reviews

FITNESS will have a direct impact on future business planning. The successful demonstration of an IEC 61850 fully digital substation will provide the necessary learning and build confidence for roll-out in future transmission price control reviews. The timing of FITNESS, with respect to planning for RIIO T2, is critical. Planning for RIIO T2 will start mid-way through RIIO T1 (i.e. ~2018-2019). FITNESS aims to successfully prove the

²¹ National Grid SOF: <http://www2.nationalgrid.com/UK/Industry-information/Future-of-Energy/System-Operability-Framework/>

digital substation concept by the end of 2018 and if successful, digital substations will be a viable option for future new-builds, replacements and modernisations for RIIO T2.

As described throughout the proposal, benefits achieved during the migration of substations from conventional through partially digital to fully digital increase, with maximum benefits derived when maintenance and future extensions are performed on full digital substations:

- The benefits will offset the initial business investment of adding NCITs, MUs, fibre optic cables, PMUs/WMUs etc.
- In a substation where all bays are digital, a future addition or modernisation to the SAS will be without the need for hardwiring or outages and can be commissioned in a substantially shorter period of time than with conventional technology.

To realise the full scale of benefits, RIIO T2 will be a key intermediate step on the road to a fully digital substation future. This is in line with carbon targets for 2035.

Technology Readiness Level and Suppliers Engagement

Process bus technology is based on the IEC 61850 9-2 standard, which is a relatively new and emerging standard. IEC 61850 9-2 Edition 2, which was released in September 2011, is accepted by suppliers and utilities internationally as a standard ready to be adopted in future devices and substations. The release of the latest version of the standard encouraged manufacturers to develop a full suite of IEC 61850 compliant equipment, such that a full digital substation could be realised and the full value chain demonstrated without need for conventional equipment to bridge the gaps. The concept and need for this demonstration project has been discussed extensively with different suppliers, TOs in GB and Europe, which leads SPT to conclude that the only way to build confidence in this technology is through a demonstration project. Our partners in this project have a keen interest in the outcomes as it will help the supplier base to evolve their technology to best suit GB TO needs.

Recent international digital substation pilot projects in India, Philippines and France demonstrate the readiness of IEC 61850 technology and supply chain availability. These projects have provided a body of knowledge and practical experience that will be applied in the GB system context in FITNESS. As practices and economics vary significantly from country to country, whilst the learning outcomes will help in identifying the risks associated with the technology to be demonstrated and will aid in successful project delivery, for all benefit cases, there is a need to have experience in the GB grid to assess the benefits in the GB environment.

Links to previous innovation funded projects

The links and relationship between FITNESS and previous innovation funded projects, such as VISOR and EFCC, is highlighted in **Appendix H**.

Section 5: Knowledge dissemination

The primary focus of knowledge dissemination in FITNESS is to enable SPEN and other GB TOs and DNOs to deploy the digital substation in business-as-usual practice. Firstly, this requires participation of stakeholders in assessing the success and readiness of the technology for deployment, and sharing the experience and questions with the technical community. Secondly, preparing to adopt the practice will involve emphasis on dissemination of practical training and experience widely within SPEN and the TO/DNOs around designing, specifying, building, commissioning and operating the substation.

FITNESS is the first live trial of a digital substation in the GB power system which includes the operation of NCITs in parallel with conventional instrument transformers. The knowledge generated by FITNESS will relate to the design, commissioning and operation of a live digital substation, and prove the compatibility of a digital substation with the future needs of the GB power system. Specifically, it is anticipated that the following will be demonstrated through FITNESS:

1. That it is possible to design, build, operate and maintain a digital substation following FITNESS in the GB power system;
2. Prove the benefits of a digital substation by quantifying the *actual* benefits realised by the GB power system when the project is carried out;
3. Operations and practices connected with a live digital substation, essential before roll out can be achieved, and guiding the evolution of designs, codes, standards, practices and training, particularly for a power system with a mixture of conventional and digital bays in a substation.

Knowledge generated within FITNESS needs to be disseminated effectively to all of the stakeholders (see Figure 11). Dissemination to a variety of stakeholders will ensure that the knowledge generated is considered from a range of perspectives beyond the core project team, which helps ensure that any hidden dependencies, flaws or opportunities can be identified and the maximum benefit can thus be extracted from the knowledge generated. The dissemination strategy is important for the project team to deliver relevant information to the appropriate audience, easily understood and accessible, at the appropriate time in order to capitalise on learning opportunities for all concerned.

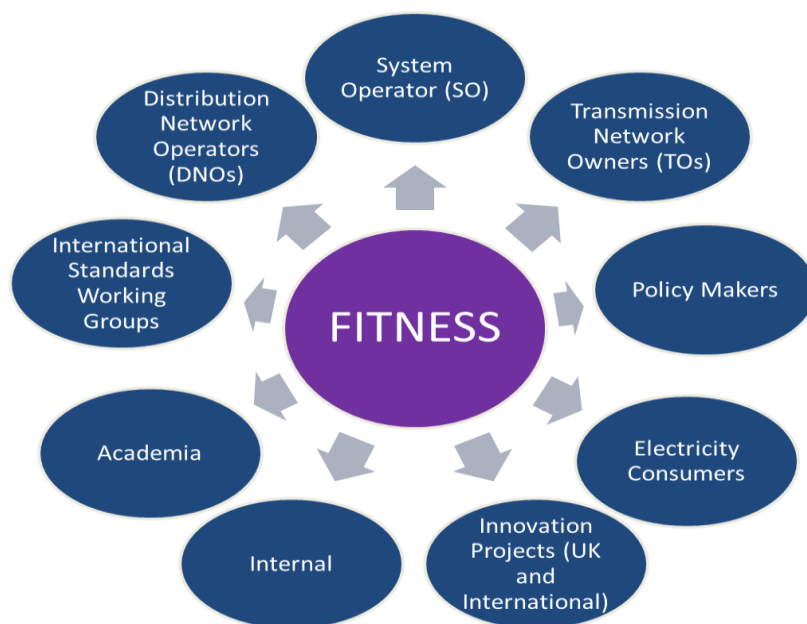

Figure 11 Key Stakeholders for FITNESS

5.1. Learning generated

This section identifies the main learning generated from FITNESS. This will include which work package(s) will generate this learning, which stakeholders will benefit from this learning, and how these stakeholders will benefit.

| # | Learning Generated | Route to Learning | WP | Beneficiaries |
|----|--|--|-----|---|
| 1 | Insight into the requirements for the specifications of digital substation hardware and for the enhancement of the relevant standards (IEC 61850) to ensure interoperability and verification of laboratory based interoperability studies and identification of how these studies should be extended in the future. | Operational experience with interoperability of devices from multiple vendors in a live substation | 2 | DNO, M , OFTO, TO |
| 2 | Performance and data quality of NCITs and distributed sensors in comparison with conventional. Assess fitness for purpose for a range of existing and new application areas, and demonstrate applications enabled or assisted by the devices. | Comparison of performance of smart grid applications for NCITs and CITs installed in parallel | 3 | M , OFTO, SO , TO |
| 3 | Design changes (bay or device), new products, specification changes, new skills, new training or new practices that are needed prior to roll out. | Commissioning, operating and maintaining digital substation hardware as part of a live substation | 2 | DNO, M , TO |
| 4 | Baseline for the data quality that applications can expect from a live digital substation and identification of modifications to laboratory based testing. | Long term comparison of the reduction of noise/errors in instrument transformer outputs for a live digital substation, both NCIT and CIT | 3 | M , OFTO, SO , TO |
| 5 | New maintenance/operating practices to guide staff when working in substations with a mixture of conventional and digital bays. | The installation and operation of digital substation bays in parallel with traditional bays | 2 | DNO, TO |
| 6 | Quantify benefits of digital substations for reduced site visits, identify any unforeseen issues that require site visits (and how to resolve these), identify best practice for achieving remote access. | Experience with remote access to a live digital substation | 2 | DNO, M , OFTO , PM , TO |
| 7 | Design approach for the process bus architecture and its effect on reliability, availability and maintainability. Generates knowledge on the processes of selecting an optimal architecture, and quantifying the expected reliability measures | Studies and methodologies developed, leading to guidelines. Validation of theoretical studies with practical observation. | 1,3 | A , M , TO , DNO, OFTO |
| 8 | Quality of the project's digital substation design in terms of physical; and cyber security, and procedures for ensuring the practical implementation of the design does not compromise its security. | Study of the cyber security of the digital substation design through negative testing by a third party of the live digital substation. Including a consideration of any flaws of the practical implementation of the design. | 1 | DNO, M , OFTO, PM , SO , TO |
| 9 | Verification of the reliability of digital substation hardware and the degree to which reliability assumptions and models are consistent with this, which is a prerequisite for even considering any roll out of new critical infrastructure. | An extended, live trial of a digital substation. This reliability data will continue to be collected and processed after the project itself has ended to provide a more long term view. | 2 | DNO, M , OFTO , PM , TO |
| 10 | Quantification of the claimed benefits of digital substations in practice (e.g. reduced failure rate, shorter repair times, reduction in constraint costs and the release of low carbon generation). | Comparison of the availability of the multi-vendor, digital substation bays and the conventional substation bays at the same site during the live trial | 2 | DNO, M , PM , TO |

| | | | | |
|----|--|---|-----|-----------------------------|
| 11 | Accuracy and reliability of protection devices within a live, multi-vendor process bus architecture. | Comparison within a single live substation | 2 | DNO, M, TO |
| 12 | Transfer times for signals in a live, multi-vendor digital substation. A study of this nature was recommended by the NIA funded AS3 project. | Dedicated study of internal transfer of signals in a live, multi-vendor digital substation | 2 | DNO, M, TO |
| 14 | Verification of the benefits of digital architecture for enabling the roll out of new smart grid solutions in the GB system. | Side by side comparison of the barriers to installing new WAMS/WACS IEDs for conventional and digital substations | 3 | C, M, PM, SO, TO |
| 15 | Best practice for delivering remote access to a digital substation and new system operation practices that could be developed in the future that exploit this remote access, e.g. adaptive protection settings based on dynamic security assessment. | Experience with remote access to a live digital substation and stakeholder engagement with SOs and offshore transmission owners | 2,3 | DNO, M, OFTO, SO, TO |

Table 4 Learning Generated, Route to Learning, and Beneficiaries

| Beneficiaries | | | |
|----------------------|--------------------------------------|-------------|------------------------------|
| A | Academia | OFTO | Offshore Transmission Owners |
| C | Consumers | PM | Policy Makers |
| DNO | Distribution Network Owners | SO | System Operator |
| M | Manufacturers and Solution Providers | TO | Transmission Owners |

In the table of learning generated the bold type face is used to denote the primary beneficiaries

Table 5 List of Beneficiaries

5.2. Learning dissemination

This dissemination strategy that has been developed for FITNESS seeks to ensure that the mechanisms are in place throughout the project to allow the project team to identify learning that should be disseminated and how best to disseminate it to the interested parties. A detailed training and workshop plan is outlined in **Appendix C (C.5)**.

In the first six months of FITNESS the project team will:

- Establish a visual identity for FITNESS that allows any dissemination material produced by FITNESS to be immediately recognisable. This identity will also extend to establishing a pack of materials that include other aspects, e.g. identifying the project partners (names/logos) and the funding source;
- Establish a knowledge dissemination coordinator who will be expected to refine the dissemination strategy throughout the course of the project to maximise the benefit of FITNESS for all stakeholders. As part of this they will be responsible for identifying dissemination opportunities, liaising with other relevant projects, maintaining an up to date list of stakeholders and establishing contacts within them, and ensuring all dissemination is consistent with the FITNESS identity;
- Identify project champions within each relevant department of the partner's business whom can ensure the project remains visible and relevant to their department. These project champions need not be a part of the core project team;
- Prepare a range of materials (e.g. posters, presentations, leaflets and videos) that clearly state what FITNESS is and what its goals/benefits are. These materials will include different versions each of which are tailored for audiences with a different level of technical knowledge; and
- Establish an online portal that will serve as the hub for dissemination of conference papers, journals etc.

In order to ensure the stakeholders remain engaged and informed a number of key activities have been identified that will be conducted and assessed on an annual cycle, including:

- Quarterly stakeholder events and/or training workshops to notify and educate stakeholders
- Quarterly progress reports and marketing material to be circulated amongst stakeholders
- Provisions for attendance and presentations at multiple industry innovation events
- Biannual continuous improvement of dissemination effectiveness

Toward the end of the project the focus will shift toward ensuring the captured learning is transferred into plans for subsequent roll-out of the FITNESS principles. A wealth of detailed reports, case studies and multimedia material will be uploaded and shared across multiple platforms and forums to provide TOs, and the wider audience, with a comprehensive account of the facts and benefits.

The knowledge dissemination strategy for FITNESS can be broken down into internal and external activities and informing standards, practices and codes.

Internal awareness and engagement

Internal knowledge dissemination, within each partner business, is a key part of ensuring the proper execution of any innovation project. It helps ensure that the personal necessary for the projects delivery, who are not a direct part of the innovation team, 'buy in' to the project and the benefits of innovation. It provides staff with the opportunity to identify the benefits and gaps in the new technology from various perspectives.

Given the major step change from conventional to digital monitoring, protection and control, internal dissemination will prove particularly important to FITNESS. This is because much of the learning generated by FITNESS will relate to operational experience developed during the installation, operation and maintenance of a live digital substation. To maximise the benefit of this will require 'buy in' from many departments within the business, which will require the staff responsible for this day-to-day operation to engage with the innovation. The dissemination coordinator and project champions will be at the heart of this dissemination, using materials prepared by the core project team, and other forums, such as existing internal innovation days and dedicated workshops with participants from the project team and across the stakeholders, will support them. This dissemination will allow the exchange of key skills relevant for understanding FITNESS and the cross-fertilisation of industrial and academic views

External engagement with the wider industry and academia

The many possible benefits of digital substations mean that their design and operation is an area of great interest for the wider industry and academia, both within GB and internationally. Therefore, as the first live trial of a digital substation in GB, FITNESS will also be of great interest. Knowledge sharing with these other researchers and projects will help ensure that FITNESS considers any many viewpoints as possible, which should maximise its benefit. For example, engaging with DNOs and OFTOs through the planned workshops and existing channels will be an essential part of external knowledge dissemination for FITNESS. This will highlight the benefits these stakeholders may enjoy by adopting digital substations (e.g. remote access) and identify how best to migrate this new technology from onshore transmission to their businesses.

The project website will serve a major role in ensuring the visibility of FITNESS and that project results/reports are available to a wide audience. Beyond this, the academic partner will be primarily responsible for delivering this external knowledge dissemination, both to a technical and non-technical audience. This will also include publishing journal and conference papers that raise the profile of FITNESS and disseminate its results to a broad audience through green open access. Relevant conferences are also an excellent opportunity to informally disseminate knowledge and gain new insights into FITNESS and its possible benefits. The academic partner will also participate actively in relevant national/international bodies to help maximise the benefit of FITNESS, e.g. EPSRC, HubNet, Cigre/IEEE working groups and related activities. Furthermore, the academic partner will identify new calls for proposals at all levels, e.g. DECC, Horizon2020, collaborative projects with China, India and Brazil, to ensure on-going exploitation of the knowledge generated by FITNESS. The annual Low Carbon Network Innovation (LCNI) conference has been identified as one of the key venues for knowledge dissemination for FITNESS.

The FITNESS team will also encourage information exchange with other demonstration projects and trialling in other countries, such as RTE France's Poste Intelligent project.

Standards, codes and practices

The IEC 61850 standard is a critical enabler for a live digital substation, as it provides a framework for interoperability of solutions from multiple vendors. Equally, the knowledge generated within FITNESS dealing with the interoperability and reliability of a live digital substation will be a key enabler for enhancing this standard and others. Furthermore, on-going interaction with other live trials and the IEC standards body will increase the international profile of FITNESS and enhance FITNESS by allowing the project team to consider the inclusion of any learning generated by these projects as part of FITNESS. Direct interaction with the other GB TOs is necessary help to ensure that any recommendations made by the project are applicable to the other GB TOs and DNOs for lower voltages. The best way to achieve this is on-going dissemination and interaction through a working group.

5.3. IPR

FITNESS will conform to the default intellectual property rights (IPR) arrangements. It is not anticipated that the developments carried out in FITNESS will fall outside IPR arrangements defined in the NIC governance document.

Section 6: Project Readiness

6.1. Overview

FITNESS is planned to start in April 2016 and robustly deliver the necessary learning by March 2020, in time to apply the digital substation technology in business-as-usual rollout in the RIIO T2 planning and investment period. The emphasis of the project is on integration and interoperability between products that have recently become commercially available, but have not been proven in a complete end to end live, multi-vendor system in GB. In order to achieve interoperability and for successful project delivery, an experienced project team comprising experts from SP Transmission Network Planning and Regulation, SPEN Engineering Services, different vendors with access to the world's leading product ranges and SME with emerging innovative technologies have been selected and involved from pre-proposal stage, and will continue involvement during project delivery.

Level of Protection. The overall level of protection of 5% for cost-overruns for the project is appropriate for FITNESS, in alignment with the NIC default. There are no Direct Benefits expected in the project, so it is not vulnerable to shortfall.

6.2. Project start

The project partners have been selected by a competitive process prior to full proposal submission, as described in **Appendix D**. The selection takes account of the partners experience in related projects in GB and internationally, the product range offered, and engagement in the collaboration and innovation process. The management team and technical experts involved in the proposal development will provide continuity to commence the project quickly following a positive funding decision. Additionally, SP Transmission Investment Review Group has approved the project for business investment to account for licensee compulsory contribution.

The expertise and leadership in the partnership for FITNESS are key to the timely start of the project. SPEN and the Iberdrola group are leaders in applying the IEC 61850 standard, though not yet in implementing the Process Bus architecture in GB. Alstom Grid and ABB are global leaders in digital substation technology, in a position to deliver a full solution and incorporate the interoperability tests. The Alstom Grid team also has a strong track record of innovation and leadership in wide area monitoring and control, and network management. SPEN and its selected lead partners have been involved in previous NIC funding rounds, and therefore have a precedent of collaboration and working under the NIC contractual framework. The risk of delays on contractual agreement is therefore minimal. Furthermore, Alstom Grid's and ABB's management has been briefed at senior management level, and support has been expressed.

The Steering Committee comprises senior SPEN personnel with decision-making authority and stakeholding in the project to follow through a successful FITNESS outcome to business-as-usual strategy. An Advisory Board brings a wider GB perspective as well as international co-ordination. The Advisory Board includes GB transmission stakeholders represented by Dr Ray Zhang (National Grid TO) and Mohseen Mohammed (SHE Transmission Ltd) whose involvement is important for wider GB rollout, and guidance from Prof Robin MacLaren, who brings technical and strategic senior management experience

and liaison between utility industry, SMEs and academia. The Advisory Board also includes Dr Alexander Apostolov, an internationally recognised pioneer in technology based on the IEC 61850 standards, and can facilitate co-ordination with international projects and standards working groups with related goals (see Appendix J: PACWorld Letter of Support).

Dr Zhang, along with Dr Haiyu Li from the University of Manchester, bring direct experience from the National Grid AS3 project, and will ensure that the learning outcomes of AS3 and related innovation work used effectively in FITNESS without unnecessary repetition. Dr Apostolov is also editor-in-chief of prestigious PAC world magazine providing FITNESS a good platform for knowledge dissemination.

Project managers will be assigned from the start of the project by SPEN and the partners to participate in the Project Delivery Team, providing continuity from the proposal stage. Technical personnel will be initially assigned from within the partner engineering teams. Where appropriate, project managers and technical personnel will be hired as the project progresses, but continuity of senior engineers overseeing the project will be maintained. Pen portraits of the key personnel are included in **Appendix I**.

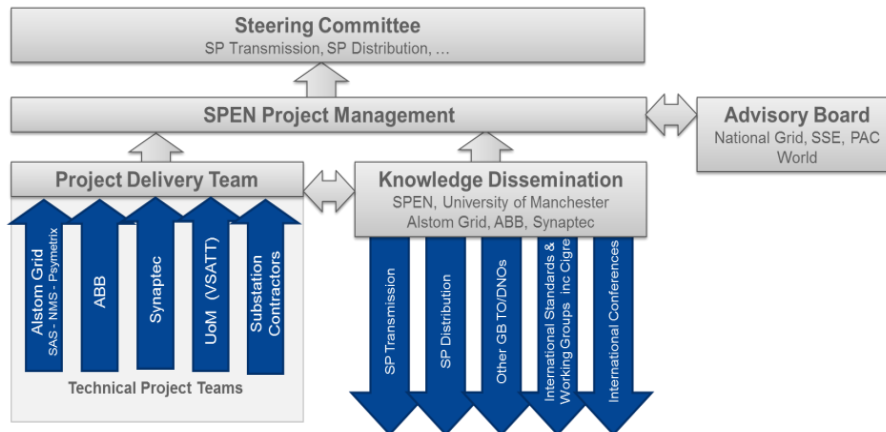

Figure 12 Structure of FITNESS

6.3. Project plan

A project plan is detailed in **Appendix E**. The project plan for FITNESS is co-ordinated with the business-as-usual development of a substation in the modernisation programme. For acceptable risk, conventional instrumentation is installed in parallel with the FITNESS equipment as a redundant pair, such that failure of the FITNESS protection will not result in equipment damage.

The project duration is four years, to allow for the substation modernisation to complete and enable the project to include a period of live operation of the substation with the FITNESS equipment in parallel with conventional equipment. The lead-time before substation installation, which is dictated by the substation building and outage programme, also serves as an opportunity for thorough laboratory testing of interoperability and dissemination workshops and training of all stakeholders prior to installation. This leads to increased confidence to apply the equipment in the live environment.

The project comprises five work packages:

- **WP1 Substation design.** Study based work package, in first 6 months of project, leading to architecture and design for laboratory and live environments
- **WP2 Substation performance.**
 - Phase 1: Laboratory-based testing and demonstration, also providing an environment for WP5 training package. To Complete 28/09/2017
 - Phase 2: Live installation and commissioning in the substation, followed by continued live operation to the end of the project.
- **WP3 Substation-to-System Information & Control Integration.** Demonstrate first in laboratory environment, completed by 30/06/2017, followed by live demonstration and integration by 28/09/2018, and revisions of reports from demonstration by 30/11/2018 and 30/11/2019 shortly after bay installations.
- **WP4 Security.** Access and compliance with security standards demonstrated in laboratory environment, followed by live system demonstration. Risk assessment and recommendation, including wide area control assessment.
- **WP5 Knowledge dissemination.** Continues throughout the project. The opportunity of WP2 Phase 1 laboratory setup is used extensively for training and dissemination throughout SPEN and other interested parties (Transmission, Distribution, and other TOs) in practical hands-on training **Appendix C (C.5)**.

Selected key dates and milestones of the project are:

- | | |
|--|------------|
| • Kick-off | 01/04/2016 |
| • WP1 Substation Design Complete | 29/09/2016 |
| • WP2 Off-line trials complete | 28/09/2017 |
| • WP5 Digital Substation training complete for install | 28/11/2018 |
| • WP2 Substation Bay#1 – live operation starts | 30/08/2018 |
| • WP3 Information exchange & application demo | 28/09/2018 |
| • WP3 Flexible control infrastructure demonstration | 28/09/2018 |
| • WP2 Substation Bay#2 – live operation starts | 31/08/2019 |
| • Close down | 31/03/2020 |

6.4. Cost-benefit estimation methodology

Cost benefit estimation was carried out to provide the information presented in Sections 3 and 4, and described in **Appendix B**. The sources of information used in this evaluation included:

1. SPEN’s internal experience of the business-as-usual cost baseline for substation building and modernisation costs
2. Supplier-provided equipment and services costs
3. International literature and supplier experience on trials with IEC 61850 Process Bus, such as cost and outage time reduction, and reliability/availability analysis
4. Learning from related NIC, NIA and IFI projects
5. SPEN’s substation bay modernisation and build programme
6. National Grid’s SOF²², FES, ETYS²³, Transmission Investment plans, and projections of key planning scenarios
7. SHE TL Transmission Investment plans

The SP scenario was used generally among all other scenarios in FES, as a conservative assumption for benefits, and the sensitivity to various scenarios tested.

²² <http://www2.nationalgrid.com/UK/Industry-information/Future-of-Energy/System-Operability-Framework/>

²³ <http://www2.nationalgrid.com/UK/Industry-information/Future-of-Energy/Electricity-Ten-Year-Statement/>

The project costs were assessed and validated through SPEN’s engagement with suppliers. The competitive process described in **Appendix D** provided information to ensure that the project delivers value for money. The selection of partners was reviewed and approved by the SPEN board.

The Cost Benefit Analysis (CBA) is described in **Appendix B**, which is the result of an extensive process of reviewing several areas of anticipated benefits, which vary according to the future scenario and level of uptake of the technology. A cost benefit analysis tool was built for the assessment, allowing the proposal development team to test the sensitivity assumptions made. The CBA tool is available on request from SPEN. The CBA was developed by SPEN with input and review by the partners (supplier and academic) and by independent consultants. The results were further reviewed within SPEN by the Transmission Network Manager and his team before a final review and approval by the SPEN Board of Directors.

Iberdrola Environmental Engineering group also conducted a life cycle analysis to compare environmental impact of digital substations as compared to conventional substations and the report generated provided some meaningful insight into the impact of manufacturing to commissioning of substations on different areas such as fossil depletion, CO2 emissions, ionizing radiation etc., available on request from SPEN. The report concluded in favour of digital substations due its reduced levels of environmental impact.

The participants in related innovation projects listed in **Appendix H** were consulted extensively to estimate the expected benefits that would be enabled.

6.5. Minimising risk of cost over-run

The risks of cost over-run in FITNESS are generally are considered to be modest, and in line with the general expectations for an NIC project. In general, the two main areas of cost over-run risk are related to:

- Unproven interoperability of multi-vendor equipment and demonstration of all protection, monitoring and control capabilities required in a digital substation design.
- The interaction between the business-as-usual project for substation modernisation (with associated outage schedule) and the FITNESS demonstration additions.

The table below describes the key cost risks and the mitigation approaches. Other project risks are presented in the Risk Register in **Appendix F**.

| Risk of Cost Over-Run | Mitigation |
|--|---|
| <p>Interoperability issues between different manufacturers’ equipment, which has not yet been demonstrated, leading to more time commitment than expected</p> | <ol style="list-style-type: none"> 1. Interoperability will be trialled in a test environment at an early stage, prior to installation at the substation as problems can be resolved much faster and at lower cost in the test environment than in the substation. 2. Study and review of the digital substation architecture and acceptance by the multiple vendors and scientific advisors 3. Lead suppliers will factory-test the architecture and overall scheme 4. The entire scheme will be tested in the offline environment, with input from the offline project personnel |
| <p>Greater physical space requirements of parallel business-as-usual and FITNESS equipment.</p> | <ol style="list-style-type: none"> 1. A number of candidate substations have been identified by SPEN, and there is flexibility to change to a different substation, if the first choice is unsuitable. 2. Within the substation, there is flexibility to choose the particular bays where the equipment is installed |

| | |
|--|---|
| Cost implication of insufficient relay room space required for IEDs. | 3. Containerised solution proposed for instrumentation without requirements for new civil structures for the relay room. |
| Changes to business-as-usual maintenance schedule impacting the FITNESS schedule – cost issue either with additional design cost project delay | <ol style="list-style-type: none"> 1. Installation targeted early in the project to allow for scope to allow slippage without impacting project costs. 2. Agreement for some flexibility of timing of effort with suppliers and stakeholders 3. More than one candidate substation site-surveyed at early stage, to keep options open for detailed design work and installation without re-work. |
| FITNESS issues delaying business-as-usual modernisation; outage time is critical and cannot be extended to problems arising due to FITNESS. Over-run of an outage can be very costly. | <ol style="list-style-type: none"> 1. Full pre-commissioning tests of entire system so that installation task is minimised. 2. Identify minimum critical installation work in substation that must be achieved during outage, e.g. NCIT and MU installations and switchyard fibre routing. Other work on IED installation & commissioning can be done later without outage. |

Table 6 Mitigation Measures for Cost Over-Run

6.6. Technology Readiness Level

The core of FITNESS relates to demonstration of newly available substation products, ready but as yet unproven on the GB grid. The innovation is related to the integration and interoperability of the whole system in the substation, and the opportunities afforded to improve the interaction between the substation and the external monitoring and control functions.

The project includes a range of Technology Readiness Levels (TRLs). It may be noted that an IEC 61850 Process Bus has never been used in the GB power system for protection or monitoring, and therefore none of the equipment or systems using it can be considered “proven in operational environment” (TRL 9). Manufacturers have been developing solutions and are now at a point at which tested products are available, so the component products are generally at TRL 7-8. Application functions that derive and present information using the quality and dynamic range, such as harmonics and fault location are at lower TRL as they naturally follow after the data infrastructure. Likewise, there has not been an opportunity to trial wide area controls based on IEC 61850 GOOSE in a Digital Substation environment.

Taken as a whole, the TRL of the project (Table 7) is sufficiently high that there is high confidence in a successful installation and valuable learning without risks of safety or loss, while the outcomes of integration, interoperability and information application are not proven for business-as-usual deployment.

| Item | TRL |
|--|-----|
| NCIT-MU voltage and current transformers with MU, publishing to Process Bus | 8 |
| Process bus equipment and architecture | 8 |
| Protection IEDs | 8 |
| Synchrophasor and fault recording using digital sampled waveform input from Process Bus | 7 |
| Redundant GPS/Glonass time synchronisation, IEC 1588 v2 format | 7 |
| Synchrophasor data from conventional and Digital Substation, delivered to central wide area monitoring | 7 |
| Distributed Optical Sensor Technology | 5 |
| Substation-based topology validation and data quality checking prior to communication to external subscriber | 5 |

| | |
|--|----------|
| Flexible wide area control capability incorporating synchrophasor measurement, and implemented over IEC 61850 GOOSE over Process Bus or Station Bus | 5 |
| Harmonics and fault information extracted from Process Bus data, processed and communicated in standard form, and analysed for real-time and post-event users. | 5 |
| Protection IED group settings selected from operational condition of system | 7 |
| Substation Control System for use with protection, monitoring and control devices from multiple vendors, in 61850 Process Bus/Station Bus implementation | 8 |
| Full substation system with multi-vendor equipment and integration to external information and control requirements | 6 |

Table 7 Technology Readiness Level of Key FITNESS Components

6.7. Verification process for accuracy of information

The overall process for verification of the project involves a number of stages of stakeholder engagement:

- Initial engagement, information exchange on needs, ideas and offering;
- Selection of lead partner and consultants, on basis of quality of solution offered, engagement with the innovation process, and cost;
- Workshop on project proposed contents, SPEN stakeholders and suppliers, reviewing and refining the planning for the project.

The proposal is drafted by the SPEN team with support from partners. The accuracy of the information was verified as follows:

- Review by SPEN Future Networks Team with partners on the accuracy of the information in the proposal;
- Draft approved by SPEN Future Networks Team for review by wider SPEN stakeholders;
- Review by engineering management stakeholders, particularly in asset management;
- Review and approval by SPEN board.

Regarding costs, SPEN initially carried out a request for information and costing prior to partner selection. Suppliers were encouraged to propose innovative solutions, and SPEN engaged with the suppliers to discuss and review the proposals. While the pricing was not like-for-like, the process provided some validation of the costs vs content of the offerings. Furthermore, information was requested from similar innovative projects elsewhere, in particular with RTE, the French SO, where a similar IEC 61850 project was carried out. The benefits were assessed in detail by SPEN. While some consulting support was requested and provided, the cost and projected benefits were derived from SPEN’s own experience and records. Assumptions were stated and checked by SPEN Network Planning and Regulation and Engineering Services.

SPEN has engaged extensively with the SPT Business, GB TOs and key vendors during proposal development. The information sources for the project can be categorised under three categories:

1. Technology and innovation;
2. Commercial information;
3. Future needs of GB Transmission Network.

Technology and innovation related information is crucial for NIC projects to ensure the technology and solutions demonstrated have future applications and have not yet been proven in GB. Commercial information related to future of GB Transmission networks are crucial in estimating the possible benefits that FITNESS could deliver after successful completion.

Technology and innovation

Key sources for technology readiness and innovation components for FITNESS include:

- GB TOs and international TOs experience in designing and deploying substations;
- Suppliers base and projects undertaken and executed internationally and in GB;
- IEC 61850 working groups representatives and wider industry experts;
- ENA Approval list for approved protection and control equipment in GB;
- Reliability studies University of Manchester.

Commercial information

Key sources for commercial information include:

- RIIO T1 business plans from SPT (internal), NGET and SSE (public domain);
- RIIO T2 estimates from SPT Network Planning and Regulation Team;
- Constraint Payments from MBBS NGET website;
- Digital substation benefits quantification from international experience and research articles;
- Iberdrola Environmental Engineering Life Cycle Analysis Report.

Future needs of GB transmission network

Key sources for information on the future needs of GB transmission networks include:

- FES, ETYS, SOF, UK Carbon Plan;
- VISOR project delivery experience;
- Previous NIC and NIA projects.

6.8. Learning in lower take up of low carbon technologies

The proposal has used the “Slow Progression” scenario for assessing the benefit of the project, except where otherwise stated. The assumptions are therefore conservative in terms of the expected benefits. The CBA also applied for other FES scenarios and the variation of benefits between “Gone Green” and “Low Carbon Life” have been summarized as upper and lower limits in Appendix A.

While the benefits will tend to increase if low carbon technologies are adopted more rapidly, aging asset replacement is an on-going and necessary aspect of the TOs business. There is a valid environmental and business case to be made independently of the take up of low carbon technologies, for example:

- The environmental and cost benefit of reducing the footprint of the substation;
- The environmental benefit of reducing the carbon footprint of the materials used;
- Reduced cost of modernisation;
- Increased availability of the Digital Substation, reducing maintenance costs and outage time, which in turn avoids use of higher cost/higher emission generation;
- Reducing likelihood of ENS penalties.

The increased controllability of the substation is a risk mitigation for the uncertainties in planning. New transmission assets can be deferred through control solutions until the future scenario becomes clearer.

If there is a more rapid low carbon take up than expected, control solutions and reduced outage times minimise the constraints applied to the system. The learning on outage times and flexible control solutions are relevant in any scenario.

Furthermore, if the actual scenario involves take up of low carbon technologies in different parts of the GB grid, or at distribution voltage levels, the learning is transferred, and benefits gained.

Risks, Contingency Plans, Escalation and Termination

A risk register is maintained throughout the project, with input from the project team and stakeholders. Risks will be monitored, reviewed and revised on a regular basis, during monthly Project Delivery Team meetings or teleconference, and reviewed 6-monthly steering committee meetings. Where appropriate, mitigation plans will be put in place and monitored.

Given the innovative nature of the project, there may be challenges arising that influence the project outcomes. In the unlikely event where the Project Delivery Team identifies circumstances impacting the project scope or the future of the project, the project team will write an Exception Report and suggest possible mitigation actions, and send this to each member of the Project Steering Group. The SPEN project manager will call for an emergency meeting for the Steering Committee within 3 weeks upon the submission of the Exception report. The Steering Group will have 3 weeks to make a written confirmation to authorise appropriate actions.

If after assessing the Exception report, the Steering Group agrees with the Project Delivery Team that the best action is to suspend the project; a formal report from SPEN will be sent to Ofgem. This report would detail the reasons, the meeting minutes and recommendations, and sent to Ofgem within four weeks following the decision from the Steering Group, to seek its decision. The report should provide Ofgem with sufficient information to enable a decision.

If the authority grants the project team permission to halt the project (in line with NIC Governance Document 8.30-8.42) all pertinent documentation and data from project inception to the point of termination will be reviewed and distributed to project partners. The online portal will be updated with this information and (if appropriate), details on the suspension/termination of the project – to ensure these lessons are understood by supporting projects.

6.9. Project Partners



Figure 13 Project Partners

Figure 13 represents all project partners for project FITNESS and the relationship and deliverables between different partners.



ALSTOM Grid will deliver a full suite of digital substation solutions and innovative developments including the interaction with external systems for control and monitoring. The intended delivery includes:

- Protection systems, including hot standby protection devices;
- Process bus;
- NCITs and MU;
- PMUs interfaced with process bus architecture and with WAMS platform;
- Enhanced synchronised measurements introduced in VISOR for sub-synchronous oscillation;
- Wide area monitoring, power quality and disturbance features extracted from digital substation data
- Flexible wide area control infrastructure, including Aggregator and Phasor Controller functions based on the EFCC use case, but adaptable to other control needs;
- Substation Control System (SCS).

ALSTOM Grid in its response to partner selection criteria included delivery of innovative NCIT, wide area monitoring and control solutions and interface to existing PhasorPoint software deployed in project VISOR. ALSTOM will provide R&D labour contribution of £1m in kind contribution in development of its substation automation software and wide area solutions during project FITNESS.

Previous Innovation Experience: VISOR, EFCC, AS3, Poste Intelligent France



ABB will also deliver a full suite of digital substation solutions primarily to demonstrate interoperability with other technology partners and to indicate the maturity of the supply chain to deliver redundant multi-vendor solutions including:

- Protection systems, including hot standby protection devices;
- Process bus;
- NCITs and MU;
- PMUs interfaced with process bus architecture and with WAMS platform.

ABB in its partner selection criteria demonstrated strong focus on digital substations and interoperability concepts. ABB will provide £0.4m in form of R&D labour and testing equipment in kind contribution to project FITNESS.

Previous Innovation Experience: AS3, Loganlea Australia, Braemar Australia.

ALSTOM and ABB are global leaders in developing power system protection and wide area monitoring applications. Each company has invested in research and development of digital substation solutions and are constantly striving to improve their solutions through live demonstration projects such as FITNESS. ALSTOM and ABB will demonstrate multi-vendor interoperability, integration of smart grid standards at substation and central system level. ALSTOM's High voltage test facilities are available for use by the project. The multidisciplinary team of ALSTOM and ABB will also participate extensively in training, workshops and other knowledge dissemination to support the wider acceptance of the technology by internal and external stakeholders.



Synaptec is a UK based SME and spin out from University of Strathclyde. Synaptec is designing and developing its distributed sensing technology as a part of an existing NIA project. In project FITNESS Synaptec will develop interface of distributed sensors onto process bus architecture and output in IEC 61850 9-2LE formats for development of future applications based on this innovative technology.

Synaptec have developed fibre-optic voltage and current point transducers, based on Fibre Bragg gratings (FBG) technology, that have been applied successfully to power system plant diagnostics. The complete optical sensor system has been shown to be capable of measuring dynamically changing signals and has been successfully used for detecting higher order voltage and current harmonics. The hybrid voltage sensor utilizes an FBG bonded to a multilayer piezoelectric stack, while the current sensor uses a small, high-bandwidth current transformer monitored by a dedicated voltage sensor. In both cases, an FBG peak wavelength shift **can be calibrated in terms of voltage or current**, and a **temperature measurement can also be performed simultaneously using the same sensors**.

FITNESS aims to realise the potential benefits to power system instrumentation may be using the fibre-optic transducers provided by Synaptec:

- minimization of local measurement units and associated power
- flexibility in measurement location owing to the use of passive transducers addressed purely by telecoms grade optical fibre – measurement over distances as long as 100 km are possible using fibre-optic sensors, and sensor fibres are entirely compatible with telecommunication fibres that may already be installed along key data routes;

Previous Innovation Experience: Distributed Photonic Grid Instrumentation



University of Manchester (UoM) has been involved in the past with NIA projects AS3 and NIC projects VISOR and EFCC. The testing facilities established in UoM as a part of AS3 and the offline testing laboratory facility can be utilised to test the digital substation architecture, interoperability to ensure reliability of

solution before live implementation. UoM will also aid the FITNESS delivery team in knowledge capturing and dissemination activities through Cigre working Groups associated with international standards development. UoM will provide an in kind contribution of £0.15m to project FITNESS in form of RTDS simulator, technical laboratory support and project consultancy.

The UoM laboratory setup for FITNESS will be available for further use after FITNESS to GB TOs and DNOs at a discounted (approximately 40%) price for BaU testing and analysis of digital substation implementation.

Previous Innovation Experience: VISOR, EFCC, AS3



SPEN has engaged with NGET and SSE during FITNESS proposal development, and technical experts from NGET and SSE will be part of FITNESS advisory group. Their role will be to assess FITNESS

scope, avoid duplication of solutions, and define key deliverables and disseminating knowledge captured internally in NGET and SSE. All trainings and workshops will open to NGET and SSE engineers for participation and learning.

Section 7: Regulatory issues

It is not anticipated that the project will require any derogations, exemptions or changes to the regulatory arrangements.

Section 8: Customer Impact

It is not expected that FITNESS will have any adverse impact on customers or require access to customers' premises. FITNESS site work will be carried out in an outage period already planned under business as usual non-load programme. The nature of commissioning work (extensive factory testing) for digital substations is indicative that the existing outage period is sufficient for completion of all activities. FITNESS has a year of primary and secondary testing planned before site commissioning. There will be a period of parallel operation without taking action ("piggyback trials"), followed by parallel live operation with the FITNESS and conventional protection serving as a redundant pair of protection systems.

The partners in this project are selected carefully so they provide the necessary response to the FITNESS project. The nature of trials and demonstration carried out as part of FITNESS means there is no adverse effect on day to day operation of the grid

Section 9: Successful Delivery Reward Criteria (SDRCs)

9.1. Architecture, design and availability

| | | | |
|--|--|---|------------|
| SDRC 1 | <i>Architecture, Design and Availability</i> | Due Date | 31/12/2016 |
| Criterion | | Evidence (WP1) | |
| <p>SPECIFIC Contractual agreements between SP Transmission and project partners on project payment milestones and deliverables. Design of substation architecture based on IEC 61850 9-2 process bus architecture suitable for measurement, protection, monitoring and control, with analysis of its expected reliability and availability. Includes also a methodology for site survey, selecting the physical layout, verifying communications and equipment connections and performing analysis of protection availability; as well as figures to compare expectation for conventional and non-conventional design.</p> <p>MEASURABLE Reports delivered. Acceptance of implementation plan by contractor. Agreement on contractual conditions and project deliverables between SP Transmission and Project Partners.</p> <p>ACHIEVABLE Draws on experience from projects such as RTE (France) 'Postes Intelligents' and GB AS3 projects.</p> <p>RELEVANT Required for implementing both the test environment and live substation. Also, comparable or better availability is critical for business-as-usual roll out digital substation.</p> <p>TIME-BOUNDED Submitted by 31/12/2016 following completion of WP1</p> | | <ol style="list-style-type: none"> 1. Contracts with project partners (<i>June 2016</i>) 2. Report on architecture & design of substation secondary system (<i>August 2016</i>) 3. Report on reliability/availability analysis (<i>Nov 2016</i>) 4. Report on bay selection, site survey, engineering feasibility (<i>August 2016</i>) 5. Engineering design for NCIT & MU installation (<i>July 2016</i>) 6. Letter confirming agreement with contractors/subcontractors for site works. (<i>Dec 2016</i>) | |

9.2. Lab functionality and interoperability testing of protection and monitoring

| | | | |
|---|--|---|------------|
| SDRC 2 | <i>Lab Functionality and Interoperability Testing of Protection and Monitoring</i> | Due Date | 31/04/2018 |
| Criterion | | Evidence (WP2, 2.1) | |
| <p>SPECIFIC Design and implementation of test environment environments for a) HV primary plant interface and b) LV secondary system demo and trial. Protection and monitoring functionality and interoperability test plans defined and carried out in laboratory environment. Tests aim at proving interoperability between different manufacturers' measurement equipment, protection IEDs and breaker controllers.</p> <p>MEASURABLE Report on test environment setup and test plan. Test report completed. Each test designed to report pass/fail or reservation.</p> | | <ol style="list-style-type: none"> 1. Report on Functionality & Interoperability Tests (Lab tests), including description of (<i>April 2017</i>) <ol style="list-style-type: none"> a. Test Plan b. Test Environment 2. Report on Low voltage secondary systems testing results. (<i>Nov 2017</i>) 3. Report on Functionality & Interoperability Tests (High Voltage tests), including description of (<i>Nov 2017</i>) | |

| | |
|---|---|
| <p>Outstanding issues reported and resolutions proposed</p> <p>ACHIEVABLE While some uncertainty is associated with interoperability (it has not been done elsewhere), if failures occur, they can be resolved directly or raised with suppliers and standards committee.</p> <p>RELEVANT Critical importance – proving interoperability is a core requirement for digital substation to become business-as-usual.</p> <p>TIME-BOUNDED Complete by 31/04/2018, with sufficient time for any outstanding issues to be resolved prior to live operation.</p> | <ul style="list-style-type: none"> a. Test Plan b. Test Environment <ul style="list-style-type: none"> 4. Report on High voltage secondary systems testing results. (<i>Jan 2018</i>) 5. Report on diagnosis of outstanding issues, and plan for resolution (<i>Mar 2018</i>) |
|---|---|

9.3. Integrating information with SCADA/EMS/WAMS (central system) monitoring applications

| | | | |
|--|---|---|-------------------------------|
| SDRC 3 | <i>Integrating Information with SCADA/EMS/WAMS (Central System) Monitoring Applications</i> | Due Date | Initial 31/12/2017 +revisions |
| Criterion | | Evidence (WP3, 3.1) | |
| <p>SPECIFIC Prove that digital substation measurements can provide improved data quality for disturbance, harmonics and synchrophasor measurements. A full measurement chain will be tested in different paths between primary plant and secondary monitoring equipment (conventional hardware, NCIT, conventional-MU, Distributed Sensors), with known inputs created for testing. Includes topology checking and measurement validation at substation, prior to communication to central WAMS/EMS.</p> <p>MEASURABLE Successful outcome are, as appropriate (1) errors within tolerances expected in the standards and (2) accuracy of applications depending on the measurements acceptable for end-use (3) similar or better quality and reliability than conventional path.</p> <p>ACHIEVABLE VISOR and previous experience has shown expected data quality and application performance of conventional measurement path. Next step of proving consistency with Digital Substation achieved by similar process as previous WAMS testing.</p> <p>RELEVANT Disturbance recording, harmonics and WAMS monitoring must be achieved in the digital substation. It is important to prove in a controlled environment that the end-to-end data quality and consistency is sufficient for business-as-usual use.</p> <p>TIME-BOUNDED Completed tests by end of 2017, ready for live operation by August 2018. Revisions with real data end 2018, end 2019.</p> | | <ul style="list-style-type: none"> 1. Report on implementing and testing NCIT/MU to PMU/DFR/harmonics measurement chain (including data quality) (<i>March 2017</i>) 2. Report on topology & measurement validation of substation-to-system information (<i>May 2017</i>) 3. Report on central information infrastructure integration and enhancement (<i>August 2017</i>) <ul style="list-style-type: none"> a. Standard EMS/WAMS integration b. New WAMS data types c. Applying CIM to data referencing 4. Report on applications exercising data quality (<i>October 2017</i>) <ul style="list-style-type: none"> a. Fault information mgt b. Harmonics management 5. Include experience from Bay #1 & Bay #2 performance trials, once available (<i>Revisions Nov 2018, Nov 2019</i>) | |

9.4. Wide area control infrastructure

| | | | |
|---|---|---|------------|
| SDRC 4 | <i>Wide Area Control Infrastructure</i> | Due Date | 01/10/2018 |
| Criterion | | Evidence (WP3, 3.2) | |
| <p>SPECIFIC Demonstrate that the digital substation can include wide area control infrastructure, and that latency and flexibility are sufficient for the control applications foreseen. Demonstrate specific use cases to enable innovation rollout (EFCC) and adaptive protection. Study feasibility of voltage stability control.</p> <p>MEASURABLE Latency and data continuity are key measurable elements of wide area control. Prove that correct signals are sent/received in the intended timeframe.</p> <p>ACHIEVABLE Prototyping tests have shown that timescales for the EFCC are achievable, and experience on international projects has shown that data quality and consistency requirements can be met.</p> <p>RELEVANT Innovation projects in GB e.g. NIC EFCC, NIA Smart Transmission Zone, NIC-bid South East Smart Grid, and distribution IFI ACAM all explore wide area control opportunities. FITNESS is an enabler for many other projects, making roll-out faster, simpler and lower cost.</p> <p>TIME-BOUNDED Completion by 01/10/2018, in preparation for substation installation and commissioning</p> | | <ol style="list-style-type: none"> 1. Report on flexible phasor-based control platform & interfaces (<i>Mar 2018</i>) 2. Report on EFCC use case and associated substation-to-system interaction (<i>May 2018</i>) 3. Report on feasibility of wide area voltage stability (<i>July 2018</i>) 4. Report on adaptive protection central logic and substation-to-system interaction (<i>Oct 2018</i>) | |

9.5. Substation installation and commissioning

| | | | |
|---|--|--|------------|
| SDRC 5 | <i>Substation Installation & Commissioning</i> | Due Date | 31/11/2019 |
| Criterion | | Evidence (WP2, 2.2 & 2.3) | |
| <p>SPECIFIC Commissioning of the full digital substation installation on two bays, proving implementation and interoperability in the live substation. Integration and test of distributed optical sensors over IEC 61850 9-2LE and consistency with conventional measurement.</p> <p>MEASURABLE Site acceptance test process performed, with pass/fail/reservation assessment. Comparisons of trigger times between conventional and non-conventional achieved during commissioning.</p> <p>ACHIEVABLE Previous interoperability and performance tests (see SDRC 2/3) ensure that</p> | | <ol style="list-style-type: none"> 1. Bay #1 Site Test Report (<i>Jun 2018</i>) 2. Bay #1 Installation & commissioning Report (<i>Nov 2018</i>) 3. Bay #1 Distributed Optical Sensor integration & test (<i>July 2018</i>) 4. Bay #2 Site Test Report (<i>Jun 2019</i>) 5. Bay #2 Installation & commissioning Report (<i>Nov 2019</i>) | |

| | |
|---|--|
| <p>sufficient planning and testing is done to avoid issues arising at Commissioning stage</p> <p>RELEVANT Commissioning in a live substation and subsequent live operation is core to the goals of the project, demonstrating that a full-scale Digital Substation design is ready for system operation.</p> <p>TIME-BOUNDED Commissioning date of 31/12/2017 defined by business-as-usual modernisation and outage window.</p> | <p>6. Bay #2 Distributed Optical Sensor integration & test (July 2019)</p> |
|---|--|

9.6. Extended live operation trial

| | | | |
|--|--------------------------------------|--|------------|
| SDRC 6 | <i>Extended Live Operation Trial</i> | Due Date | 31/03/2020 |
| Criterion | | Evidence (WP2 2.2, 2.3, 2.4) | |
| <p>SPECIFIC Live operation period starting with piggy-back trial, leading to period of live closed-loop trial. Experience reported</p> <p>MEASURABLE Continuous observation of measurements enables long-run consistency checks of conventional and non-conventional measurements. Any disturbances or protection operations at or near the substation are captured and studied.</p> <p>ACHIEVABLE A very large body of work has led up to a live operation trial, and there is broad industry consensus that it can and should be done.</p> <p>RELEVANT Live trial in parallel with conventional backup is a critical proof of digital substation readiness for business-as-usual deployment.</p> <p>TIME-BOUNDED Interim reports on completion of respective trial periods. Completion of Bay #1 reports 31/3/2019 allowing sufficient time for learning from experience prior to commissioning of second bay later in 2019. Completion of final report by close-out.</p> | | <ol style="list-style-type: none"> 1. Report on Bay #1 piggy-back trial phase (Feb 2019) 2. Report on Bay #1 live operation trial phase (July 2019) 3. Report on Bay #2 live operation trial phase (Nov 2019) 4. Report on Extended Live Performance Trials (Mar 2020) | |

9.7. Cyber security

| | | | |
|---|-----------------------|--|------------|
| SDRC 7 | <i>Cyber Security</i> | Due Date | 31/11/2019 |
| Criterion | | Evidence (WP4, 4.1) | |
| <p>SPECIFIC Development of risk assessment strategy and tools to test security levels at substations and between substations and central systems.</p> <p>MEASURABLE Risk assessment strategy and live risk assessment of security robustness.</p> <p>ACHIEVABLE Cyber security for standards and protocols currently being researched and project partners involved in FITNESS adhere to international security standards.</p> | | <ol style="list-style-type: none"> 1. Report on cyber security measures in the substation (Dec 2016) 2. Risk assessment for the FITNESS substation (May 2019) 3. Demo remote access, data transfer and security measures (Mar 2018) 4. Demo remote access, data transfer and security measures –(Mar 2019) | |

| | |
|--|--|
| <p>RELEVANT Cyber security is necessary to ensure data transfer security and integrity between disparate systems. Risk assessment is necessary to avoid cyber-attacks.</p> <p>TIME-BOUNDED Report summarizing risk assessment technique and robustness of existing security standards and protocols.</p> | <p>5. Investigate/compare IEEE C37.118 and IEC 61850 90-5 with respect to cyber security (Aug 2019)</p> <p>6. Report on cyber security for Wide Area Control infrastructure (Nov 2019)</p> |
|--|--|

9.8. Knowledge capture and dissemination

| | | | |
|---|--|---|-----------|
| SDRC 8 | <i>Knowledge Capture and Dissemination</i> | Due Date | 31/3/2020 |
| Criterion | | Evidence (WP5, 5.1) | |
| <p>SPECIFIC Knowledge capture and dissemination amongst Transmission & Distribution Owners, and industrial and academic community.</p> <p>MEASURABLE Report outlining the training sessions and workshops delivered, conferences, technical visits. Technical papers included as appendix.</p> <p>ACHIEVABLE Time and resources included for knowledge dissemination.</p> <p>RELEVANT Strong interest expressed by key industry stakeholder in GB and internationally in project goals.</p> <p>TIME-BOUNDED Report summarising the knowledge capture delivered by project close-out (31/03/2020)</p> | | <p>1. Training & Workshop plan for TOs and DNOs.(Dec 2016)</p> <p>2. Report on on-going training & workshop sessions delivered (June 2017, Dec 2017, June 2018, Dec 2018, June 2019, Dec 2019, Mar 2020)</p> <p>3. Report on Cigre B5 working group participation & contributions to standards bodies (August 2017, Mar 2018, Jul 2018, Nov 2018, Mar 2019, Jul 2019, Nov 2019)</p> <p>4. GB Stakeholder and Dissemination Events organised (August 2017, 2018, 2019)</p> <p>5. Annual Innovation conference participation (Nov 2017, 2018, 2019)</p> | |

List of Appendices

| | |
|----------|--|
| A | Benefits Tables |
| B | Cost Benefit Analysis |
| C | Supplementary Project Description |
| D | Project and Partner Selection Plan |
| E | Project Plan |
| F | Risk Register and Contingency Plan |
| G | Base Case Value Derivation |
| H | Links to Previous Innovation Funded Projects |
| I | Organogram and Key Personnel |
| J | Letters of Support |
| K | Glossary of Terms |

Appendix A: Benefits Tables

| KEY | | | | | | | | |
|---|---|-------------|----------------|---------|--------|---------|--|---|
| Method | Method name | | | | | | | |
| Method 1 | Digital substation architecture, design and commissioning (DS ADC) | | | | | | | |
| | Benefit Constraint Payments (DS CP) (This is not a method but has been separated to distinguish between TO and SO benefits) | | | | | | | |
| Method 2 | Digital Substation Operations and Maintenance (DS OM) | | | | | | | |
| Electricity NIC – financial benefits | | | | | | | | |
| Financial benefit (£m) | | | | | | | | |
| Scale | Method | Method Cost | Base Case Cost | Benefit | | | Notes | Cross-reference s |
| | | | | 2020 | 2030 | 2050 | | |
| Post-trial solution <i>(individual deployment)</i> | DS ADC | | | - | 0.12 | 0.23 | DS ADC: All benefits are stated per bay. Bay in this context refers to feeder bay as FITNESS will be demonstrated on feeder bay at 275kV. The method cost will be higher in 1 st 8 years as replacements will be a mixture of conventional and digital solutions £0.91m. The method costs will drop once more bays are digital and market for digital substations grows that will in a <i>conservative</i> estimate drive the costs down to £0.8m. The savings for constraint payments are not included here as they will vary from feeder to feeder and have been only included in roll-out calculations. DS OM: This covers costs for modernisation, operations and maintenance of digital bays, and addition of monitoring equipment and sensors. | Section 3 and Appendix B B.2, Appendix G |
| | CP | | | - | - | - | | |
| | DS OM | | | - | 0.09 | 0.13 | | |
| Licensee scale <i>If applicable, indicate the number of relevant sites on the Licensees' network.</i> | DS ADC | | | 0.02 | 16-24 | 78-137 | For roll-out at licensee scale the number of switchgear bays in RIIO-T1 load and non-load related business plans [REDACTED] were replicated at different sensitivities into RIIO T2, T3, T4, T5. The base and method costs represent non-discounted cumulative investment costs for all voltage levels at transmission level for SPT till 2050. Sensitivities assumed: Dependant on FES and uptake of digital substations. Maximum - Gone Green Scenario, Full Digital Uptake (More digital bays) Minimum - Low Carbon Life, Partial Digital Uptake (Less digital bays). The uptake of digital substations is assumed to be higher for SPT than other TOs. DS OM: It is assumed on basis of SOP that there will be more (x1.5) monitoring and modernisation work required for secondary side in RIIO T2 and onwards aligning with changing levels of inertia and fault levels. | Section 3 and Benefits Appendix B B.2, Appendix G |
| | CP | | | 0.18 | 6-18 | 42-95 | | |
| | DS OM | | | - | 1-2 | 7-12 | | |
| GB rollout scale <i>If applicable, indicate the number of relevant sites on the GB network.</i> | DS ADC | | | 0.15 | 71-107 | 572-858 | The same analogy as above is applied to other TOs in GB, using assumptions based on their RIIO T1 business plans and by comparison of size of transmission networks for each TO (NGET x4, SSE =1). The uptake of digital substations in other TOs is assumed to be lower than SPT. Constraint payments listed in licensee scale is the constraint payments that will be paid by SO due to constraints in TO network due to planned outage requirements. All costs are cumulative up to 2050. NOTE: All benefits are replicable at distribution networks, however not modelled in this financial benefit calculation. | Benefits Appendix B B.2, Appendix G |
| | CP | | | 0.75 | 37-80 | 260-592 | | |
| | DS OM | | | - | 8-12 | 49-74 | | |

| Electricity NIC – carbon and/or environmental benefits | | | | | | | | |
|---|--|-------------|----------------|------|-------|---------|---|------------------------------|
| Capacity released and/ or environmental benefit (£m) using traded carbon price (£/t 2012/13 prices – £7.3) | | | | | | | | |
| Scale | Method | Method Cost | Base Case Cost | 2020 | 2030 | 2050 | Notes | Cross-references |
| Post-trial solution <i>(individual deployment)</i> | | | | | | | Carbon benefits per trial is very much dependant on where the trial is being undertaken, e.g. what part of GB. Thus the carbon benefits have not been quantified per trial but rather on licensee and GB roll-out scale. | |
| Licensee scale <i>If applicable, indicate the number of relevant sites on the Licensees' network.</i> | DS ADC DS OP | | | - | 5-13 | 80-201 | Carbon Benefits have been expressed in £m based on Government assumptions of cost per tonne of carbon. The same sensitivities as described above are applied to calculation of these values as well. This carbon savings are derived from the reduction in use of copper and the carbon savings that increased levels of wind generation in the network will offset; (due to reduced constraints on the network) | |
| GB rollout scale <i>If applicable, indicate the number of relevant sites on the GB network.</i> | DS ADC DS OP | | | - | 13-34 | 200-503 | The percentage of carbon benefits is assumed to be higher in SP Transmission area due to higher integration of wind and more uptake of digital substations enabled operations and maintenance methods. All other assumptions are same as above. | Section 3 and Appendix B B.3 |
| <i>If applicable, indicate any carbon and/or environmental benefits which cannot be expressed in £m.</i> | Post-trial solution: [Explain any carbon and/ or environmental benefits which cannot be expressed as kVA or kWh] | | | | | | . Other environmental benefits that will be realised include: <ul style="list-style-type: none"> Benefit of 10% less land use for new build substations Reduction in civil works requirements and lighter transformers will mean reduced use of heavy machinery and the emissions associated Travel to site. Reduction in the use of other materials such as iron, oil and gas at substations. Reduced EMC levels at substations Detailed substation life cycle analysis indicates other benefits of reduction in fossil depletion and ionizing radiation | Section 3 and Appendix B B.3 |
| | Licensee scale: [Explain any carbon and/ or environmental benefits which cannot be expressed as capacity or kVA or kWh] | | | | | | | |
| | GB rollout scale: [Explain any carbon and/ or environmental benefits which cannot be expressed as kVA or kWh] | | | | | | | |

Appendix B: Cost Benefit Analysis

B.1. Benefits Summary

A comprehensive CBA has been carried out for quantifying the benefits after successful demonstration of project FITNESS. Summary key benefits realised through the project are:

- Substation cost reduction realised by the TO;
- Cost savings from improved operational flexibility of substation;
- Carbon, environmental and other societal benefits;
- Outages and constraints savings to the SO.

B.2. Assumptions

The projected uptake of the digital substation solution has been calculated based on the level of load and non-load related investment that will be carried out between 2020 and 2050 for feeder bays (switchgear, referred to as bays from here on). The percentage figures presented in the CBA are percentage of the average cost of building or replacing a transmission bay. The predicted equivalent investment schedules for NGET and SHET have been calculated using scaling factors based on the relative sizes of their transmission network in comparison to SPT.

The total number of bays that will need to be built, or that will require some work, will change depending on the FES for GG, SP and LCL. The No Progression scenario has not been included in the analysis as it is thought to be the most unlikely scenario. The FES where developed by National Grid on the basis of security of supply, affordability and sustainability. The numbers of bays have been calculated as follows:

- For GG scenario, the number of bays that were built and refurbished in RIIO T1 has been multiplied by a factor of 1.2 for T2 to T5.
- For SP scenario, the number of bays that were built and refurbished in RIIO T1 has been multiplied by a factor of 1 for T2 to T5.
- For LCL scenario, the number of bays that were built and refurbished in RIIO T1 has been multiplied by a factor of 0.8 for T2 to T5.

In addition to the FES, two other scenarios have been developed which are related to the expected success of the FITNESS demonstration project, and hence the expected uptake of the digital substation solution. The two scenarios are PU and FD.

- FD Scenario – more viability of Digital Substations
- PU Scenario – lesser viability of Digital Substations.

All benefit cases equally apply to GB DNOs and OFTOs. However in order to keep the benefits calculation relevant to the scale of project FITNESS, the benefits calculations have been performed on future replications at transmission voltage levels only.

The FITNESS uptake scenario factors are presented in Figure 5 (main body of proposal) for RIIO T2 and in Figure 14 for RIIO T3 below are used to calculate the amount of bays that will be digital, compared to the total amount of bays in load and non-load related investments given the projected future energy scenario. For RIIO T3 to T5 the level of uptake in the FD and PU options has been assumed to increase due to a likely increase in

industry confidence in the solution. The comparative number of bays in RIIO T3 to T5 is given in Figure 14 and Figure 15 below.

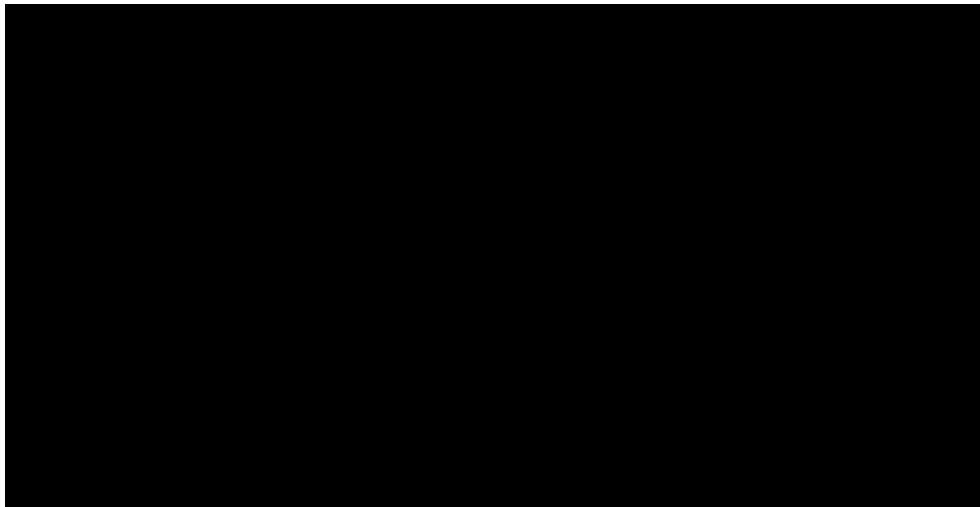

Figure 14 No. of Digital Bays and FES and Uptake Factors for RIIO T3

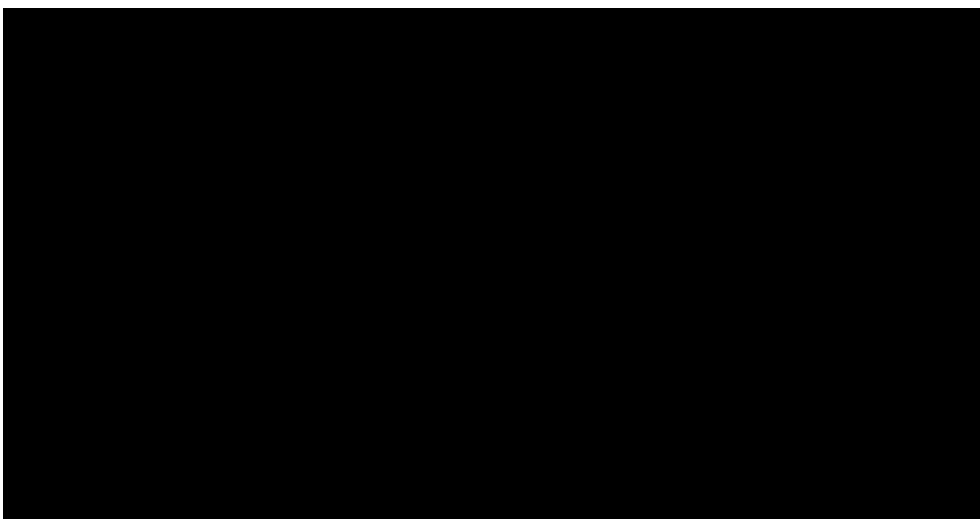

Figure 15 No. of Digital Bays and FES and Uptake Factors for each investment period after RIIO T3

The cumulative uptake of FITNESS across the whole GB network is expected to be exponential until 100% of bay replacements and new builds are digital. In the FITNESS roadmap concept, the 100% digital GB network for both new builds and replacement of bays is expected to be realised after 2037. The cumulative financial benefits realised through the uptake of the digital substation solution between 2020 and 2050, assuming a FD uptake, in the GG scenario, was presented in Figure 9 in the main body of the proposal.

A comparison of the costs per bay for a conventional bay, a conventional to digital bay replacement, a new build bay and a digital to digital bay replacement is presented in Figure 8 in the main body of the proposal and in Figure 16.

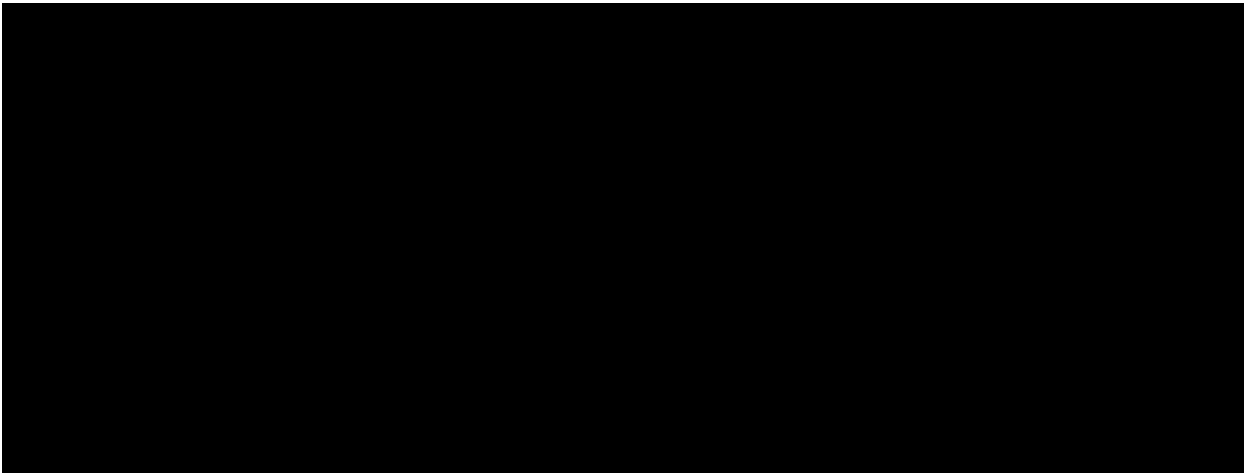

Figure 16 Detailed Breakdown of Cost Reductions

These savings equate to a net cost effect of:

- New build, reduction of **12%** of bay cost per bay;
- Replacement, reduction of **9.4%** of bay cost per bay.

In addition to the savings for equipment and construction, there are also additional savings in the pre-site planning stage. The savings in total planning costs per substation has been estimated to be 5%, which equates to a reduction of 24 months to 22 months and is based on reduced planning due to simplicity of design of substation secondary system. Per substation, this is estimated to be a reduction of 42 days to 40 days per bay, saving the TO the cost of engineer and project manager man days (assuming a cost per man day of £500).

The total substation footprint will be reduced by 10% through the roll-out of FITNESS owing to the following factors:

- Smaller and lighter NCITs;
- Smaller relay panels which can be fitted within fewer kiosks;
- Replacement of copper hardwiring with fibre cables.

There will be a reduction in the safety risks associated with a conventional substation, which can be quantified as the risk of pay-out for minor injuries, loss of productivity and fatalities²⁴. Typical safety improvements are:

- Reduction in construction time and the time workers spend on site, hence less exposure to the risks associated with substations;
- Reduction in use of copper wiring between primary and secondary, lowering the risk of electrocution;
- Mitigation of risk of open core CTs, hazardous failure CTs due to moisture ingress or over-heating.

Substation safety issues are ultimately societal costs as any medical care or loss of productivity from injury or fatality will impact the wider society in terms of loss of GDP from reduced productivity of workers, and costs borne by the NHS in the UK. However,

²⁴ 'Safety risk management for electrical transmission and distribution line construction' Alex Albert, Matthew R. Hallowell, University of Colorado.

since GB TOs follow best practices and the probability of a serious event is very low, these benefits have not been included in the calculation for financial benefits and only been described for information. It may be noted that benefits such as reduced build time and outage reduction are derived from the inherently safer technology.

The process of producing copper emits CO₂, therefore any reduction in the use of this material will have a positive impact on the environment from the point of view of reduced emissions. The reduction in use of copper hardwiring in the digital substation, due to replacement with optical fibres, will result in carbon savings. Per substation, there is an estimated reduction of 50 tonnes of CO₂. This equates to 5 tonnes per bay, assuming 10 bays per substation. The financial cost to society per tonne of CO₂ due to the use of copper in substations is given as an annual fixed price from Government sources.²⁵

The assumptions for Constraint payments for next 15 years were calculated from Energy Ten Year Statement, 2014. It is assumed 65% of outage related constraint payments account for planned outages for substations replacements and modernisation work. The reduction in planned outages for replacement per bay is assumed to be from ten weeks to five weeks, whilst for modernisation per bay from six weeks to two weeks using FITNESS digital substation solution. The reduction in the planned outage duration is estimated on basis of performing all secondary protection system assembling and testing in factory and thus reducing site commissioning time. As digital substations do not require cable end testing and large relay panels the commissioning of secondary system can be compared to installing a server and connecting it to a communications network via Ethernet. However as there are operational risks associated, the outage duration is required for site testing. As industry gains more confidence in digital solutions these outage durations can be further minimised and optimistically reduced to a day for modernisation works.

ENS payments are based on a fixed penalty payment of £12,000 per MWh. The probability of the risk of payment is calculated from the actual energy shortfall in 2014 by SP Transmission, compared to the total potential shortfall that could have been realised in the same year if every bay modernisation incurred an outage for the entire duration of the work. The probability of incurring an ENS payment is low (~0.001) and is associated with faults in network during planned outage duration; this probability is multiplied to the total potential outage that could be incurred over periods RIIO T2 through to T5 given the level of digital uptake.

As the historic constraint payment figures show, wind power is restricted due to lack of network capacity which is in part due to transmission asset outage. Therefore, reducing the duration of planned outages for replacement and modernisation works can increase the overall wind power generation that is made available, as well as reducing CO₂ emission levels. This integration of low carbon generation is important, in particular wind power, and is a key factor to meet the UK carbon reduction plan.

The calculations for constraints on wind generation are based on the projected wind output from the FES, which varies for GG, SP and LCL. The average level of emissions of electricity generation by long term marginal plant is equal to 430,000g of CO₂ per MWh²⁶.

²⁵ <https://www.gov.uk/carbon-valuation>

²⁶ <http://www.pfr.co.uk/pfr/3/Renewable-Energy/15/Wind-Power/64/How-Much-Carbon-Dioxide/>

B.3. FITNESS Financial Benefits

As described in Section B.2, The financial benefits depend on what the future uptake of the digital solution will be after the FITNESS demonstration period has been completed. The benefits that will be realised will range from a maximum achievable benefit in the GG FD Scenario, to the minimum achievable benefit in the LCL PU Scenario. The net savings across these scenarios are the sum of potential cost savings from 2020 – 2050, which covers the investment schedules RIIO T2, T3 and T4, as well as the last two years of RIIO T1 and the first five years of RIIO T5.



Figure 17: Maximum and Minimum levels of benefits achievable through FITNESS

The financial benefits from FITNESS are realised through a number of key savings in the substation design and operation. These key savings are the relative savings per digital new builds, replacement and modernisation works that has been assumed in the project and discussed in Section B.2. A summary of the overall financial benefits, split between category and whom the benefits are realised by is presented in Figure 9 of the main report.

Substation cost

The reduction in the cost of bay new builds is 12% from the conventional scenario, whilst bay replacement has a cost reduction of 9.4%. The total substation costs savings are made up of reductions in use of copper, civil costs, commissioning, engineer’s planning time. The reduction in land costs are estimated for new builds only. The non-discounted net financial savings due to reduced bay costs will realise by year 2050 a maximum value in the GG FD scenario of **£858m**, and a minimum saving of **£572m** in the LCL PU Scenario.

Operational Flexibility

Improved Operational Flexibility realised through FITNESS will have financial benefits for the TO. The benefits associated with operational flexibility are due to reduced duration of modernisation works in a digital substation and reductions in number of times engineers have to travel to site. As the dynamics of the network change in the future with increased levels of intermittent low carbon generation, related monitoring protection, automation and control installation could increase by a factor of 1.5 as compared to RIIO T1. Currently, modernisation work is delayed due to requirement of planned outages on heavily constrained parts of the network and the costs associated with adding additional equipment to the substation. As digital solutions reduce the outage window required for critical modernisation works by a factor of 60% and for non-critical modernisation works e.g. addition of a monitoring unit to zero. This will significantly improve the operational flexibility of transmission and also if applied of distribution networks.

The total non-discounted savings that could be realised due to the reduced risk for installation and maintenance will be a maximum of **£67m** in the GG FD scenario, and a minimum of **£45m** in the LCL PU scenario. Clearly, the installation of monitoring and

control schemes yield financial benefits depending on the specific issue addressed. The FITNESS project shows that the installation costs are lower, and delivery or roll-out is shorter than conventional practice, so the benefits of such schemes are derived earlier.

Relationships between FITNESS and other control-related innovation projects are described in Appendix H.

Outages

Planned outages result in network constraints by restricting generation output from connected generators. Planned outages have constraint payments associated which is incurred by the System Operator. The total savings in constraint payments for replacements and modernisation works across the time period 2020 – 2050 will be a maximum non-discounted saving of **£592m** in the GG FD scenario. In the constraint cost projections provided by the FES, the LCL scenario incurs higher constraint costs than SP. Therefore, in the analysis the minimum constraint cost saving from FITNESS will be the SP PU Scenario, returning a non-discounted value of **£260m** over the life of the project from 2020 - 2050.

Hybrid Line Fault Management

Around 15% of GB transmission lines are now hybrid underground/overground. For safety reasons, the normal overhead line procedure of re-energising a line cannot be applied to underground sections, and definitive fault location information is available, reclosure cannot be applied and the line may be out of service for hours. Distributed sensors provide this information. The FITNESS infrastructure applies new passive technology, easily transmitted from multiple measurement points through a single optical fibre to the line ends. The innovation approach described in Appendix H highlights the need, but the FITNESS technology should deliver the result at significantly lower cost per installation.

Safety

Digital Substations inherently improve the safety of workers and assets at substations by reducing the safety hazards associated with conventional CTs and a reduction in the time workers spend at substations.

The process of quantifying the cumulative risk of working in a substation has been calculate using the unit risk multiplied by the exposure duration, where unit risk is the frequency of incident measured per watt hour multiplied by the severity measured in £ per day. The reduction in risk of pay out due to injury or fatality has been calculated using an estimated percentage reduction in workers’ exposure to that risk. The nature of health and safety issues are that they are occurrences that are unpredictable and hence an actual financial cost cannot be estimated, and thus these figures have NOT been included in net financial benefits calculation. The maximum risk aversion expressed in non- discounted financial terms will be **£18m**.

Carbon and Environment

There are CO₂ savings realised through FITNESS from both reductions in equipment that have a CO₂ impact on the environment, such as copper and oil, as well as carbon savings from reduced constraints.

All reductions in substation material use, as well as other harmful emissions, such is fossil depletion, have been analysed in detail in the FITNESS **Life Cycle Analysis**. The analysis

includes evaluation of the environmental impact of transformers, relays, civil works and wiring. This study includes the first stages of the life cycle analysis, from extraction of the materials to the processing of the final components. The rest of the stages of the life cycle analysis (assembly, use and end of life) have not been considered in this study because FITNESS substation is a demonstration and the final design has not been defined for the time being. The following graphs present the most significant benefits of the digital substation by environmental category.

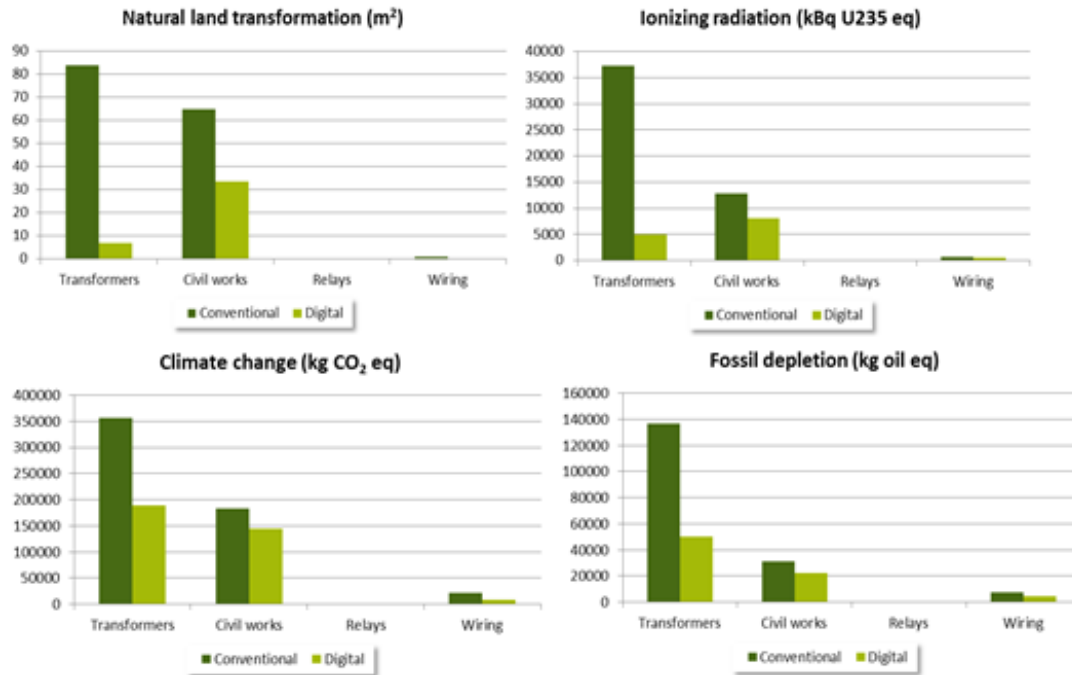

Figure 18: Significant savings by environmental category realised through FITNESS

The CO₂ savings per tonne are given by a fixed carbon price, £7.3 per tonne of carbon in 2013, rising over time. These costs are realised by the wider society in terms of the ultimate cost CO₂. For total wind constraint reduction, the maximum savings for the GG FD scenario is **£500m**, whilst the minimum potential saving in SP PU is **£200m**. The assumptions for CO₂ caused by reduction in use of copper are described in Section B.2. The total financial savings, based on the fixed cost per tonne of CO₂ each year, will be **£3.3m** for GG FD, and **£2m** for LCL PU.

B.4 Incremental benefits

The incremental benefits of undertaking this project are based on the assumption of *when*, rather than *if*, the fully digital substation concept would otherwise become part of BaU. We have made a conservative assumption that this project, and the way in which it is designed, will jumpstart the inception of fully digital substations in GB by 8 years, and, furthermore, that this project will improve the comparative uptake rate based on the collaborative nature of the NIC process. In addition to the assumed jumpstart period, a live demonstration project would *still* be necessary to prove the concept.

An incremental assessment of the benefits with FITNESS requires a certain degree of speculation - key to which are the following assumptions:

- Timing of benefits

- An 8-year jumpstart gained by FITNESS
- An improved uptake rate of 25% (through collaborative development and standard rather than international TO experience)
- Quantified financial benefits
 - Substation savings are based on the number of estimated switchgear bays load and non-load related schemes
 - Constraint savings are based on the ETYS forecasted constraint costs based slow progression and gone green scenarios

Our incremental benefit assessment, detailed within this document, estimates between **£87m to £219m** by 2030, and **£289m to £591m** by 2050 of financial savings. This estimation is a conservative figure and is strongly dependant on the 8-year jumpstart and which, of course, is speculative and may, in practice, be considerably longer.

Furthermore, there are a variety of **non-quantifiable benefits, which would not be attained, or would be significantly reduced in benefit without project FITNESS such as reducing barriers to entry for other innovative monitoring and control projects.**

Digital substation jumpstart

Without FITNESS, the GB industry would follow established international trends instead of addressing GB interests in the technology direction. We believe that digital substation technology will become established over time and obsolescence will eventually force GB to follow the digital substation route. Without FITNESS, we have estimated that the GB uptake of digital substation technology would be delayed at least until after the RIIO T2 period, thus a delay of around 8 years would be expected.

In addition to the cost implication of the delay, a GB live demonstration will still be needed before the technology is used in business-as-usual. Advantages of early uptake are not only the direct cost benefit, but also in ensuring that GB requirements are formalised in international standard revisions. In this response, we consider:

- The benefits directly accounted for in the FITNESS proposal, including reasons that that the particular benefits claimed can be derived from the FITNESS substation experience rollout.
- The impacts of not proceeding with FITNESS, delaying digital substation technology take-up until after it is widely adopted in international standard practice

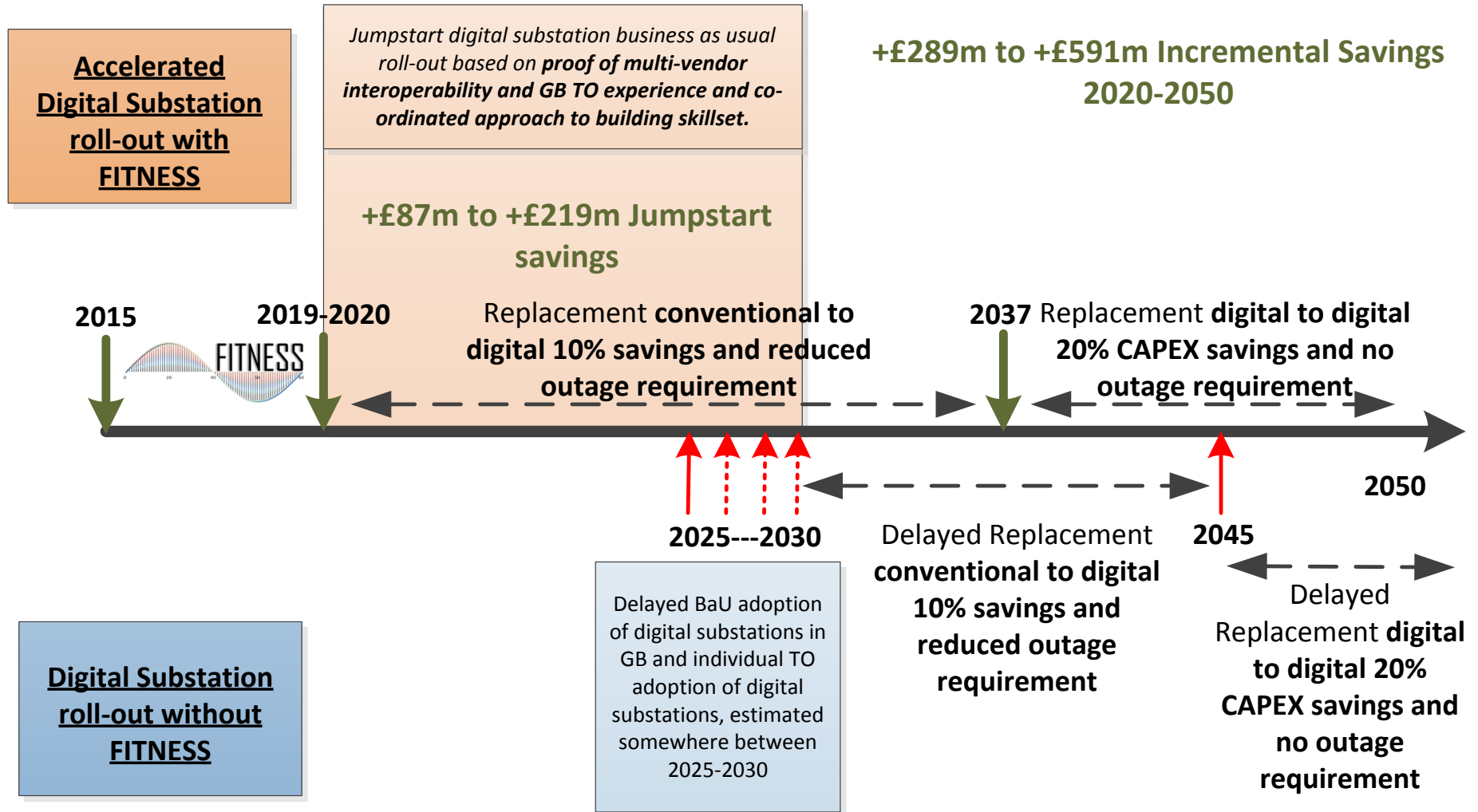

Figure 19 Digital Substation benefits with and without FITNESS

Incremental Benefit assessment (i.e. digital uptake without FITNESS)

The incremental benefit assessment is based on a comparison estimated switchgear replacements, reduction in constraint costs and operation and maintenance savings between 2030 and 2050 across different energy scenarios and different levels of digital substation uptake.

FITNESS Benefits (non-quantified)

There are several benefits that are not included in the direct cost benefit analysis for example:

- Site cost of replacement/new-build of a switchgear bay
FITNESS solution also reduces pre-site engineering design and planning time as in future work related to building foundations for CVTs and adding or building trenches for copper cables. It also simplifies design of control building. As pre-site planning time benefits cannot be accurately demonstrated through this demonstration project, these benefits are not included in final benefit calculations.
- Enabling new monitoring and control solutions
FITNESS reduces barriers and enables roll-out other innovative monitoring and control projects, such as **SPEN & partners’ VISOR and National Grid’s EFCC** and Humber Smartzone. These are scheme-specific and the FITNESS benefit cannot be assessed accurately. The benefits of these projects have been already quantified in previous NIC proposals and cannot be counted in project FITNESS.
- **Benefits to DNOs and OFTOs through roll-out of digital substations and increased market competition** and decreased equipment costs.

We therefore submit that the direct benefits claimed can be ascribed to FITNESS, and that benefits that cannot be ascribed to FITNESS alone were described but not incorporated in the overall benefit analysis figures.

It is anticipated that progression to digital substations without FITNESS in GB will follow a slow piece-meal approach resulting delayed realisation of benefits as shown below in Table 8.

| Category | 2030 | | 2050 | |
|--|---------------|---------------|---------------|----------------|
| | Upper Bound | Lower Bound | Upper Bound | Lower Bound |
| Substation Costs | £120m (GG-FD) | £56m (LCL-PU) | £273m (GG-FD) | £160m (LCL-PU) |
| Constraint Payments | £92m (GG-FD) | £28m (SP-PU) | £293m (GG-FD) | £115m (SP-PU) |
| O&M Costs | £7m (GG-FD) | £3m (LCL-PU) | £25m (GG-FD) | £14m (LCL-PU) |
| Additional Total Financial Benefits | +£219m | +£87m | +£591m | +£289m |
| Additional Carbon Benefits | +£27m | +£11m | +£234m | +£100m |

Table 8 Summary Incremental benefits FITNESS

Appendix C: Supplementary Project Description

C.1. Conventional Substation vs Digital Substation

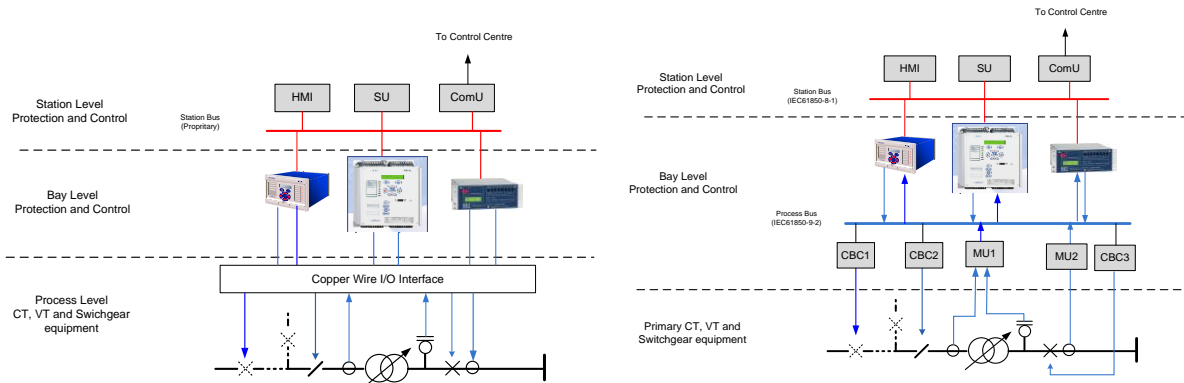

Figure 20 Conventional Substation vs Digital substation

Conventional Substation

Power system substations consist mainly of primary equipment, such as CTs, VTs, Switchgear, etc. and secondary Protection and Control (P&C) equipment, such as IEDs (Protection Relays), Human Machine Interfaces (HMI), Substation control Units (SU), Communication Units (ComU) etc. Traditionally the links between the primary equipment and the secondary P&C equipment are copper wires. As can be seen from Figure 20 the secondary equipment is directly connected through copper wires to the control circuits and the secondary sides of the primary equipment. The expected useful life of secondary equipment is shorter than that of primary equipment, therefore there is a requirement to repair/replace or service secondary P&C equipment more often than primary equipment. Due to the copper wire connection between the secondary and primary equipment, the primary equipment must be de-energised before any repair, replacement, or servicing of the secondary equipment can be carried out. This can lead to long outages which may reduce the substation reliability and availability.

Digital Substation

The IEC 61850 standard for communication networks and systems in substations is an open utility communication standard for digital substation secondary system implementation. IEC 61850 lays out a set of comprehensive documents in fourteen parts with more than a thousand pages. Among the IEC 61850 comprehensive documents, the parts of the standard directly relevant to substation protection and control devices are IEC 61850 8-1 (Station Bus) and IEC 61850 9-2 (Process Bus). GOOSE messages use the concept of broadcasting substation events to allow any IED or relay to send a GOOSE message to a specified IED or to a Circuit Breaker Control (CBC) Unit to control substation primary equipment, such as circuit breakers. The IEC 61850 9-2 standard defines how the primary equipment analogue current and voltage signals are digitised by MUs into digital sampled values (SVs). The digital SVs are then transmitted to all IEDs connected to LAN over ethernet-based optical fibre link to replace the CT and VT copper wire connections to the various devices (IEDs (relays), meters and SCADA). As can be seen in Figure 20, for digital substations, the secondary P&C equipment is connected to the process bus. MUs and CBCs are not intelligent devices, therefore malfunctions due to software bugs or settings are not a concern. The immediate benefit of digitised analogue sample values (IEC 61850 9-2) on the process bus is the ability to design and implement a digital

interface between the primary and secondary equipment, that make it much safer to carry out any repair/replacement or service for P&C equipment without taking the primary equipment out of service (i.e.the copper wire connections between the MU/CBC and primary equipment can remain in service when the secondary equipment is disconnected from the process bus). The planned outage time would therefore be much reduced; and consequently the system availability will increase significantly.

Since one of key objectives of IEC 61850 standards is to promote interoperability among different vendors, it addresses the issues of future secondary P&C equipment obsolescence and backward compatibility. One of the key aims of project FITNESS is to demonstrate multi-vendor interoperability as shown in proposed FITNESS architecture in **Figure 21**.

Proposed Digital Substation Architecture

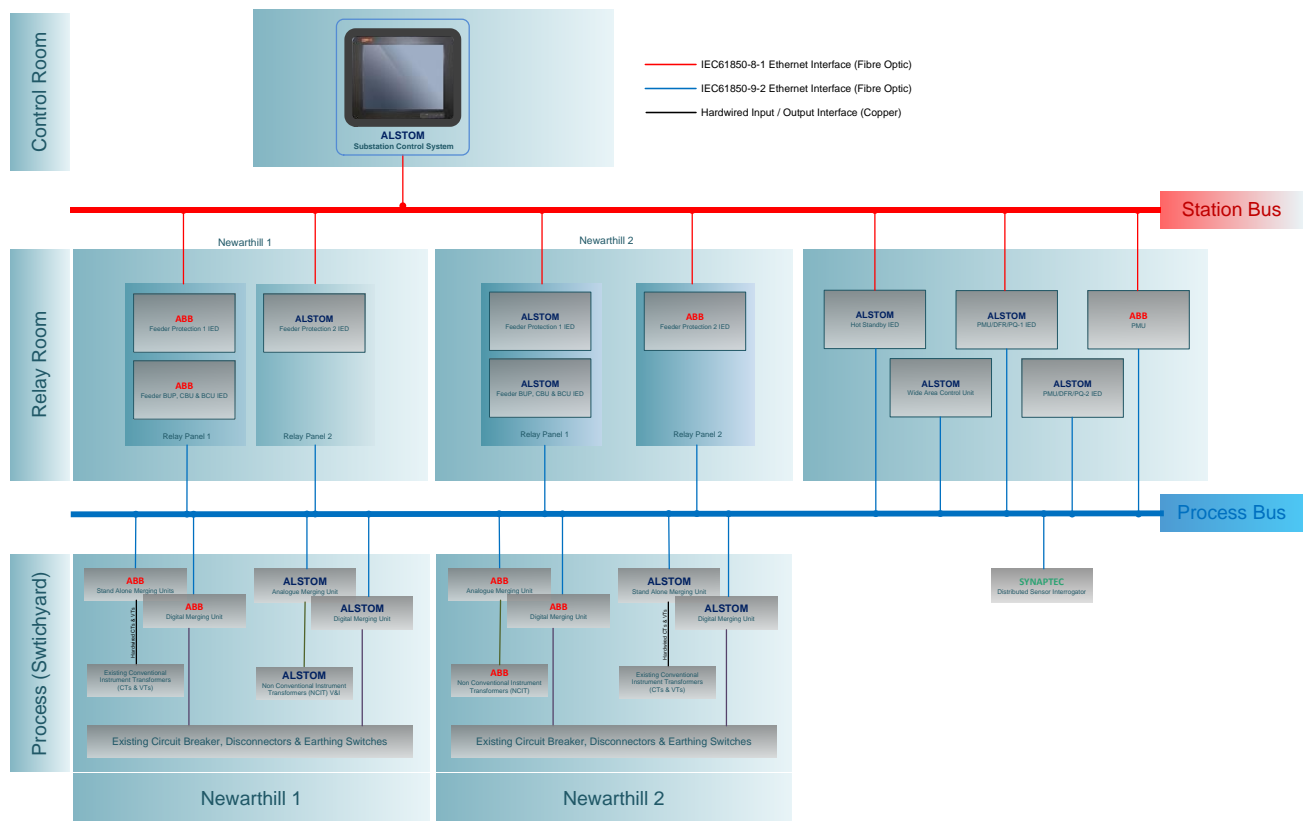

Figure 21 Overview of Proposed Digital Substation Architecture

C.2. Objectives and Methods Summary

| WP1 | Substation Design |
|------------|---|
| Objectives | <ol style="list-style-type: none"> 1. Complete design and architecture of a multi-vendor digital substation, validated by analysis of reliability, availability and maintainability, to be applied in live 275kV substation 2. The design shall conform to IEC 61850 standard for design of substation automation, including Process Bus and Station Bus, enabling interoperability demonstration and shall incorporate: <ol style="list-style-type: none"> a. Full end-to-end monitoring, protection and control functionality b. Multi-vendor NCIT and MU solutions c. Synchrophasor, fault recording and PQ measurements |

| | |
|----------------|--|
| | <ul style="list-style-type: none"> d. Novel distributed optical sensors e. Hot standby configurable IEDs f. Time synchronisation according to IEC 1588v2 standard |
| <i>Methods</i> | <ol style="list-style-type: none"> 1. Substation bay selection through site survey and approval by stakeholders 2. Determine optimum architecture for reliability, availability and maintainability through analysis and case studies 3. Define the multi-vendor equipment to demonstrate interoperability and standardised design 4. Define the practical requirements and feasibility of modular plug & play substation automation, perform reliability analysis, leading to performance testing in WP2 5. Design the test environment configuration and test plan for pre-installation tests 6. Design the physical layout for installation in the selected live substation |

| | |
|-------------------|--|
| WP2 | Substation Performance |
| <i>Objectives</i> | <ol style="list-style-type: none"> 1. Demonstrate the first full end-to-end multi-vendor digital substation, to our knowledge, from measurement to breaker actuation over fibre digital communications, with the monitoring, protection and control functions required for full-scale business-as-usual deployment. 2. Demonstrate quality and consistency of measurements for protection between multi-vendor NCIT-MUs and conventional transformers (via MUs) and prove they satisfy multi-vendor protection device requirements and interoperability with conventional remote line end measurements. 3. Demonstrate quality and consistency of measurements for monitoring of NCIT-MU and conventional transducer data for satisfying key monitoring requirements for synchrophasors, fault recorders, harmonics and fault location 4. Performance comparison between full closed loop digital protection over process bus from primary plant measurements to relay room and trip signals back to primary, against conventional system |
| <i>Methods</i> | <ol style="list-style-type: none"> 1. Deploy the WP1 design in the offline testing environment and carry out laboratory-based performance and interoperability tests. 2. Knowledge transfer from supplier to the TOs and substation installation team, of skills required for installation and commissioning of new equipment, including supplier-led training sessions and offline demonstration & workshop. Suppliers also provide support during substation installation & commissioning. 3. Deploy the WP1 design in the selected substation, initially in 'piggy-back' operation. Confirm consistency with laboratory based testing and parallel business-as-usual Main protection system. 4. Carry out commissioning tests that prove standard-compliant digital triggering (IEC 61850 GOOSE) is capable of controlling a breaker in the switchyard. 5. Deploy synchrophasor, fault recording and PQ monitoring and confirm consistency with local and remote line-end conventional monitoring, over extended time tests covering normal and disturbed system behaviour. 6. Following successful performance review and measurement consistency check, introduce the multi-vendor Digital Substation protection scheme to live operation as Main 1, alongside conventional business-as-usual |

| | |
|--|--|
| | Main 2. Continue operational service and monitor performance and any operations. |
|--|--|

| WP3 | Substation-to-System Information & Control Integration |
|-------------------|--|
| <i>Objectives</i> | <ol style="list-style-type: none"> 1. Prove that Digital Substation efficiently delivers current and emerging monitoring and control requirements, including synchrophasors, fault recording and PQ/harmonics 2. Demonstrate the Digital Substation as enabler and accelerator for rolling out low carbon innovation, including <ol style="list-style-type: none"> a. VISOR-NIC real-time synchronised phasor & scalar (@50Hz & 200Hz) b. EFCC NIC - robust wide area control infrastructure c. Smart Transmission Zone NIA – boundary stability control 3. Demonstrate ability for protection systems to adapt to system-level low carbon and power electronic penetration, in operational timeframe. |
| <i>Methods</i> | <ol style="list-style-type: none"> 1. Using WP2 installation of process-bus-enabled synchrophasor/fault recorder/PQ device, demonstrate delivery of data over standard protocols to receiving applications in central EMS and Wide Area Management System (WAMS), Fault Management, etc. 2. Prove that data quality can be enhanced by substation-level topology and measurement validation stage prior to sending to central information system, improving quality of EMS/WAMS applications. 3. Demonstrate flexible addition/enhancement of substation monitoring without outage, and opportunity for measurement redundancy 4. Demonstrate that protection group settings can be selected from wider system observations, thus enabling adaptive protection in case of low carbon generation and fault level changes 5. Demonstrate that requirements of the NIA and NIC wide area monitoring and control can be implemented in the digital substation using a standard design, with flexibility to apply various algorithms and logic to meet current and future requirements, using fast-acting control and without direct hardwiring or outage. NIC/NIA use cases will be implemented, using the outputs of the above NIA/NIC projects, and performance studied. 6. Measure the achievable control system infrastructure performance in terms of latency, data quality, reliability/availability, against requirements of the NIA/NIC control applications |

| WP4 | Security |
|-------------------|---|
| <i>Objectives</i> | <ol style="list-style-type: none"> 1. To raise awareness of the security issues associated with the Digital Substation, and show that mitigation measures and processes can be applied to minimise the risks 2. To investigate new security issues arising with wide area monitoring and control and define the processes to address them. |
| <i>Methods</i> | <ol style="list-style-type: none"> 1. Incorporate security measures in the architecture and design of the Digital Substation, incorporate the technical tools, and apply industry standard guidelines (e.g. NERC-CIP) for security practices. 2. Carry out a cybersecurity risk assessment and apply mitigation measures as appropriate. 3. Review the substation components of the wide area monitoring and control infrastructure, and define the security measures to be applied in roll-out of the technology. |

| WP5 | Knowledge Dissemination |
|-------------------|---|
| <i>Objectives</i> | <ol style="list-style-type: none"> 1. Enable stakeholders within SP Transmission to specify, design, implement and operate a Digital Substation 2. Share the experience of Digital Substation with other Transmission and Distribution Owners so that the wider GB energy networks can derive the benefits 3. Interact with industry working groups and work to identify and resolve gaps or problems with the standards, especially IEC 61850 9-2 4. Disseminate the experience to the wider international industrial and academic community |
| <i>Methods</i> | <ol style="list-style-type: none"> 1. Hands-on training events to disseminate knowledge amongst the partners and prepare for live installation 2. Stakeholder workshops for GB TO/DNOs 3. Conference participation and industry working group contributions, particularly in Cigre B5 4. Details of training and workshop plan in Appendix C C.5 |

C.4. Cyber Security

Cyber security becomes increasingly important as remote configuration, remote control and operation, and automated wide area control are used more extensively. The approach to cyber security must facilitate legitimate access and control requirements, while defending against external internal attacks. A defence in-depth strategy including multiple layers of security is implemented to counter these attacks and limit their impact. FITNESS applies practices and tools consistent with internationally accepted industry security guidelines (e.g. North American Electricity Reliability Council – Cyber Integrity Protection, NERC-CIP), and has novel elements regarding applying security principles to a wide-area control architecture.

The defence-in-depth strategy involves defining a security perimeter and providing a single controlled access point, illustrated in the figure below.

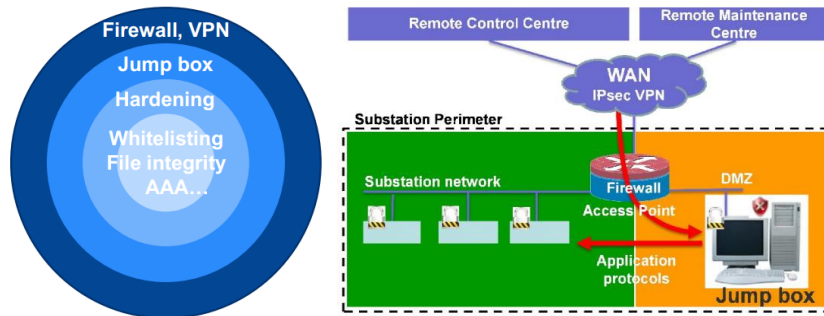

a) Defence-in-Depth Strategy

b) Security perimeter and access point

Figure 22 Cyber Security Strategy Principles in the Digital Substation

| Application | Description |
|---------------|--|
| Firewall, VPN | Communication between the substation and remote systems are tunnelled in a Virtual Private Network (VPN) – a secure encrypted point to point communications channel. The firewall separates public and private zones, and denies traffic by default. |

| | |
|---|---|
| Jump Box | A Remote Access Server that forms a single access point controlling access to other devices within the security perimeter. |
| Hardening | Refers to operating system patching, USB disabling, user accounts, password policies, software signing etc. |
| Whitelisting, file integrity, authentication-authorisation-accounting (AAA) | Authentication is required to access the substation, and each IED, using a secure password policy. Authorisation maps user accounts to the user's privileges. Auditing involves tracking all security events. Whitelisting application control denies execution of any software that is not specifically enabled. Anti-virus software may be used depending on policy. |

Table 9 Application of Defence-in-Depth Strategy

Regarding the specifics of cyber security in the digital substation, network segregation (use of VLAN) and multicast filtering are important. These features allow keeping the broadcasted GOOSE and SV within a defined perimeter, preventing protection IED flooding or leaks to the station bus.

The digital substation provides extensive remote access, secured by:

1. Use of a jump box installed in a DMZ
2. Limiting the number of protocols to the Jump Box (e.g. Remote Desktop Protocol over SSL and a secure file transfer protocol only)
3. Limit the number of protocols from the Jump Box to the station bus and process bus (use of a firewall)

All files that need be downloaded from the substation to the remote centre should reside on the jump box. These files should be 'pushed' from IEDs to the jump box rather than 'pulled' by the jump box from the IED (i.e. communication is initiated from the secure zone, the station bus/process bus, rather than from the DMZ).

Risk Assessment

A risk assessment is planned that typically includes:

1. List of sources of threats;
2. List of assets (hardware, information, communication flows);
3. List of attack scenarios;
4. Combine the above into a list of risks;
5. Propose technical or procedural mitigation actions to address or reduce risks;
6. List the residual risk.

Risks relating to Wide Area Control

The introduction of wide area measurement and control technology is of particular interest in FITNESS. FITNESS will not implement an entire wide area control scheme, but rather, it will implement the elements of a control scheme required to demonstrate the infrastructure that relates to the substation and its interfacing with external parts of the system. The security risks and mitigation measures will be investigated. A repeatable process will be developed for incorporating the functionality in the substation without a significant addition to security risks. The Figure 23 below shows a generic infrastructure

for wide area control scheme that is robust in terms of data quality and availability. It includes two key components that reside in the substation:

- **Regional Aggregator (RA):** There would be typically 10-15 RAs distributed in GB substations, of which one will be demonstrated in FITNESS. An RA receives data from several PMUs within the substation, and can incorporate remote line-end information from distributed optical sensors, and may also receive external PMU data. It outputs an aggregated data stream that will be received by multiple Phasor Controllers.
- **Phasor Controller (PC):** The PC is a controller unit that implements system-responsive distributed control, reacting to local and remote RA signals.

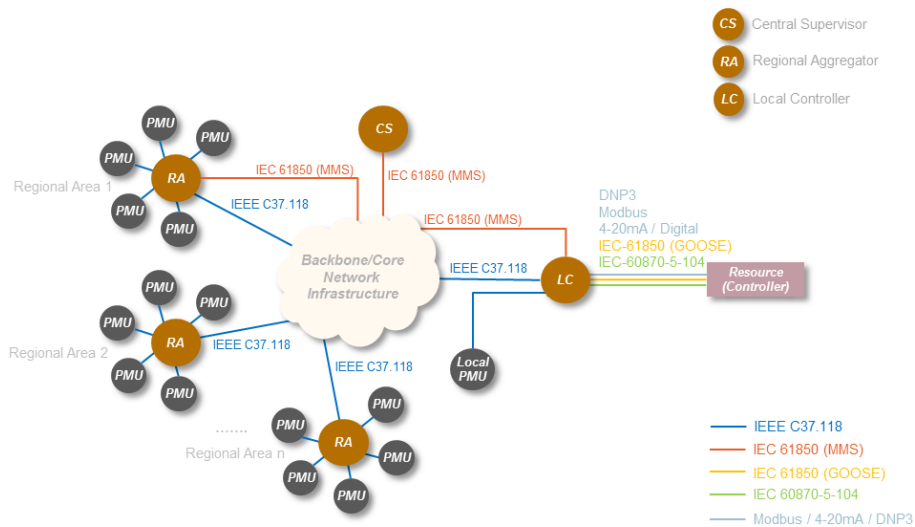

Figure 23 Generic Structure of Wide Area Control System

The RA will multicast or broadcast a data stream through a dedicated wide-area VLAN, and Phasor Controllers will receive data streams from a number of RAs in various locations to make control decisions. WP4 will investigate the security issues around this architecture and provide guidelines on the measures to be taken to ensure that the security risks are managed. One of the areas to be investigated is the relative cyber security benefits of the new IEC 61850-90-5 standard for synchrophasor measurement in comparison with the established IEEE C37.118 standard.

Work on cyber security in FITNESS will therefore include:

1. Report on cyber security in the substation design, describing measures taken and tests of cyber security
2. Risk assessment for the FITNESS installation
3. Demonstrate remote access and interfaces with substation, and security measures
 - a. In the laboratory environment
 - b. In the live substation environment
4. Report on cyber security in Wide Area Control infrastructure. Investigation and comparison of IEEE C37.118 and IEC 61850-90-5 in terms of cyber security implications, and recommendations.

C.5. Training and Workshop Plan

A knowledge dissemination plan has been developed to ensure learning acquired by FITNESS is effectively shared amongst the stakeholders, with particular focus on the Transmission Network Licensees and System Operator to ensure the onward transition into business-as-usual practice. Effective knowledge dissemination requires a coherent strategy for ensuring that the project team can deliver the proper information to the proper audience and in the proper form. Table 10 illustrates the key elements of the knowledge dissemination plan spanning the duration of the project, including the inception, annual and close-down stages.

The true success of this project will be measured by future uptake of the digital substation. Regular project delivery team (PDT) meetings, training events and workshops will ensure knowledge dissemination objectives remain integral throughout the course of the project, supplemented by regular circulation of informative project newsletters. The knowledge dissemination activities will be evaluated annually using a continuous improvement strategy, assessing feedback from events and interactive presentations and ensuring the industry remains engaged with the progress of the project. Stakeholder events will provide vital to ensure the successful communication and engagement internally and amongst the other transmission owners in order to ensure barriers to business-as-usual are addressed specifically by the project.

Furthermore, stakeholder events will ensure consideration is given from a broad range of perspectives, beyond the core project team, further guaranteeing that any hidden dependencies, flaws or opportunities can be identified and the maximum benefit can thus be extracted from the knowledge generated. It is critical to a widespread rollout of the digital substation that the processes and skills are available for business-as-usual design and deployment. A training and workshop programme is proposed that addresses needs for all stakeholders, including:

- SPEN Engineering Asset Planning;
- SPEN and contractor installation and commissioning;
- Other interested TOs – National Grid and SSE;
- Distribution network operators, including SPEN;
- Operational and analysis personnel as information users

The phase of operation in the laboratory environments provides a valuable opportunity for hands-on training, prior to installation in the live substation. In some cases, repeat courses are required to accommodate the needs of the organisations and personnel involved. Furthermore, a high voltage test facility is available in Alstom Grid’s Villeurbanne (France) site, and is useful for training in connection of new equipment (NCITs) to high voltage primary plant.

The training and workshop programme includes the following:

- Basic familiarisation of Digital Substation solution;
- Experience of installation, commissioning and operation of multi-vendor digital substation;
- Architecture, design and availability analysis;
- Basic hardware installation:
 - Connection to primary plant;
 - Secondary system installation;
- Detailed hardware functionality and configuration;
- Commissioning, testing and maintenance processes;

- Substation operations, use of Substation Control System ;
- Use of Hot Standby to enhance availability;
- Central system operations and applications;
- Designing and implementing wide area control;
- Cyber security in the digital substation.

| Stage of project | Actions | Objective/Key learning |
|--------------------------|--|--|
| Initial 6 Months | Kick-off stakeholder event | Ensure broad range of stakeholders is informed of the project objectives and timescales. An online portal to allow stakeholders to self-educate at any time. |
| | Regular PDT meetings | |
| | Setup of online portal | |
| | Creation and distribution of publicity material | |
| | Quarterly internal and external marketing material | |
| | Attendance to industry conferences | |
| Annual activities | Regular PDT meetings | Provide regular flow of project updates to keep stakeholders engaged. Bi-annual review of dissemination activities to ensure messages is conveyed effectively. |
| | Quarterly Stakeholder training / workshops | |
| | Quarterly internal and external marketing material | |
| | Attendance to industry conferences | |
| | Presenting at industry conferences | |
| | Biannual review of knowledge dissemination activities (Continuous improvement) | |
| Final 6 Months | Publication of exhaustive project learning and benefits | Publish comprehensive findings of the project, ensuring experience and benefits of the technology are well documented, ready for future roll-out. |
| | Detailed business case studies for future roll out | |
| | Close down stakeholder event, with virtual tour of digital substation | |

Table 10. Overview of Knowledge Dissemination plan.

C.6. CEN-CENELEC-ETSI Smart Grid Coordination Group

The following paragraph is European smart Grid Co-ordination Group introduction to “Methodologies to facilitate Smart Grid system interoperability through standardization, system design and testing”.

“In the transmission grid, Utilities are installing Phasor Measurement units (PMU’s) and related Smart Grid equipment. All these smart sensors and Intelligent Electronic Devices (IED’s) have integrated Information & Communication Technology (ICT) components included. The lifecycle of the ICT component and that of the primary electrical equipment may however differ. ICT components used in the grid currently have a lifetime of around 10 to 15 years, much less than primary electrical equipment that has an average lifetime of more than 30 years. In addition to that, a major concern is technological obsolescence due to the ever increasing speed of the new evolutions of ICT components, putting at risk economic feasibility of investments in grid elements based on ICT components. In the ICT industry we see a trend from mass production to mass customization already at the more visible ‘front’ side: user-centric application designs, ‘bring your own device’, customization, personalization etc. The next big mass customization trend will be to do that also in the back-office architectures, especially by introducing open standards, interoperability and a

more granular (finer) modular design of components that can more easily interact. Innovations in the areas of Cloud computing, Agent technology, Internet of Things among others will further enable this transition and will be a catalyst for true distributed, decentralized, simpler architectures. Centralized architectures will be replaced more and more by distributed/decentralized variants that are truly interoperable.”²⁷

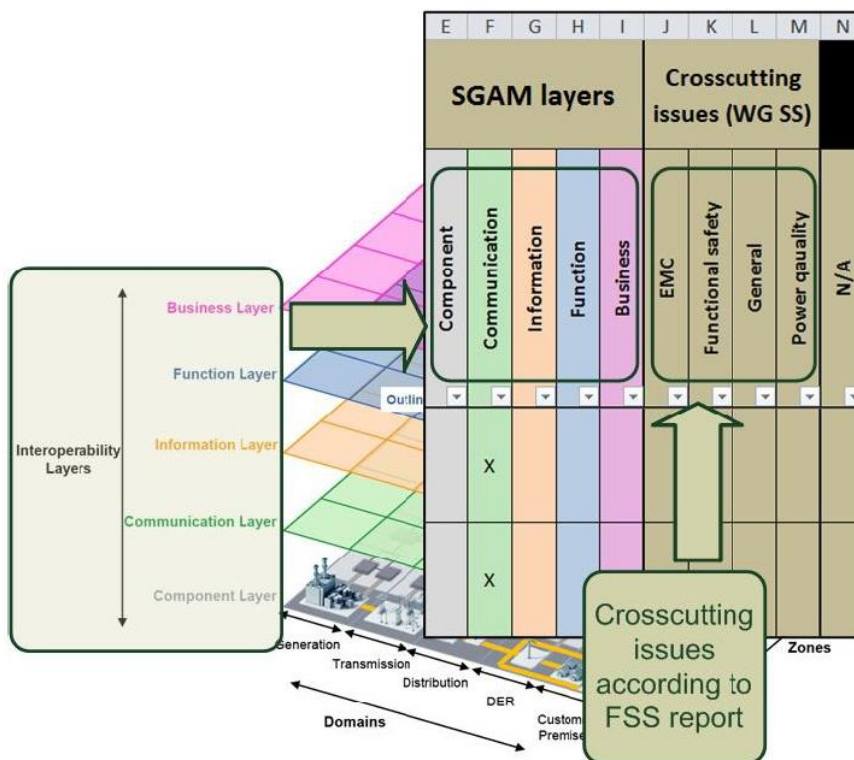

Figure 24 Smart Grid Architecture Model Layers and Crosscutting Issues²¹

FITNESS aims to follow this methodology thoroughly throughout project delivery to demonstrate multi-vendor interoperability and identify any gaps in standards for smart grids to report to working groups and smart grid co-ordination groups.

²⁷ SG-CG/M490/I_Smart Grid Interoperability

Appendix D: Project and Partner Selection

D.1. Project Selection

An extensive internal and external stakeholder engagement for selecting FITNESS for the 2015 RIIO NIC was carried out. FITNESS was conceptualised by analysing the key areas for innovation requirements in SPT. As stated in SPT's Innovation Strategy review (2014), the main requirements for innovation are in the areas of interoperability and intelligence [Ref].

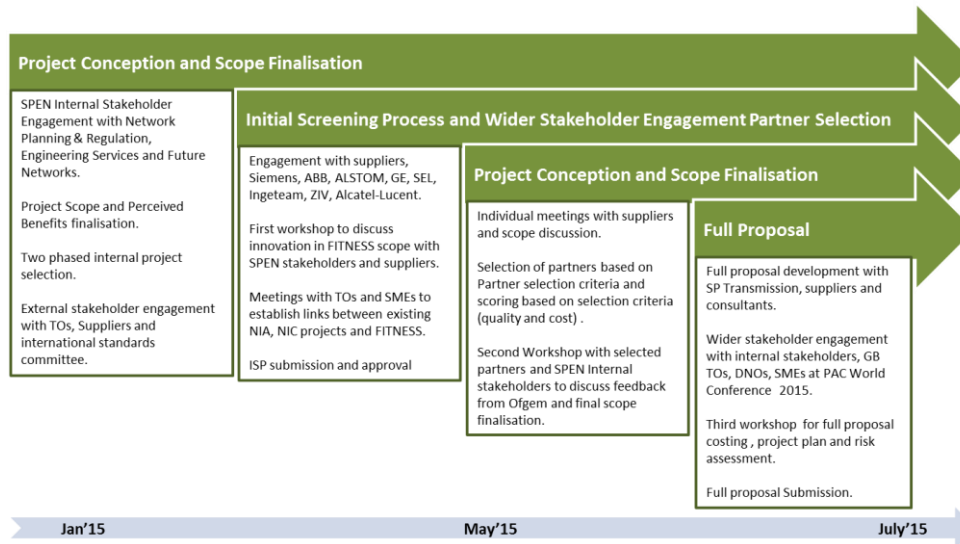

Figure 25 FITNESS Proposal Development Key Stages

The concept of moving to a fully digital substation design concept and the feasibility and necessity of undertaking a demonstration project to prove concept and gain necessary experience in RIIO T1 to enable planning for RIIO T2 was discussed with the Network Planning and Regulation team and analysed by SPT's Engineering Services and Design team. The project scope was thus established to include IEC 61850 9-2 Process Bus architecture, integration of PAC and WAMS concepts and integration with central systems for seamless transition after proof of concept to business-as-usual. The scope and innovation components were then verified by engaging with GB TOs (NGET and SSE) and international TOs (RTE). A brief scope was sent to suppliers to gauge interest in the supply chain for innovation in substation design. All major suppliers e.g. ALSTOM, ABB, SIEMENS, GE, SEL, ZIV, Ingeteam and Alcatel-Lucent proved willing to participate in the project and offered help in identifying key innovation components.

A two staged internal review process was staged in February 2015 to identify the probable projects for 2015 NIC submission. FITNESS was selected after internal evaluation for innovation and benefits for submission under the SPT Licensee.

FITNESS proposal team and key SPT stakeholders were identified and the first workshop, held in February 2015, was used to finalise the project scope and create the partner selection criteria with the involvement of suppliers. Individual meetings were carried out with all suppliers, TOs and international stakeholders involved in IEC 61850 standards committee to confirm the innovative aspects of the project and gain assurance that to prove the process bus concept, a live demonstration project would be required.

FITNESS was submitted for Initial Screening Process (ISP) in April 2015 and after being successful in the screening process was developed further into a full proposal.

During the ISP to Full Submission process, the FITNESS proposal development team carried out rigorous partner selection activities to assess each vendor against a number of criteria including quality and costs, with key partners being identified through this process.

A detailed CBA was undertaken to determine and quantify all benefits and a feasibility study was undertaken to determine the reliability, availability and maintainability of Process Bus based fully digital substations.

A wider stakeholder engagement was undertaken at the PAC World Conference in June 2015, where 150 guests were in attendance, to determine interest in FITNESS from key industry players. The results of the stakeholder engagement survey are presented in Figure 26.

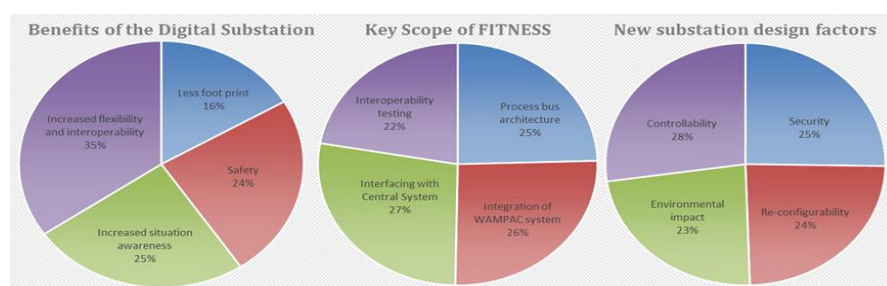

Figure 26 PAC World Stakeholder Engagement Survey

Stakeholder feedback is presented in Figure 27.

| Name (Required) | Company (Required) | Position | Email Address (Required) | Please note your feedback below on the 'FITNESS' presentation... |
|-------------------------|-------------------------------|--|------------------------------------|--|
| Neil Mitchell | SSE/University of Strathclyde | Protection engineer | neilmitch16@hotmail.com | Very useful and interesting to learn from. |
| Bryan Gwyn | Quanta Technology | Vice President | Bgwyn@quanta-technology.com | Very well thought through. On the benefits, have you taken into account the offset of the cost of technology transfer and training of configuring IEC 61850 architecture |
| Laura Kane | SGS | Analyst | Lkane@smartergridsolutions.com | There will be a need to focus on 61850 standards...this could make or break the project case to ofgem |
| Akira Kobayashi | Energy Technologies Institute | ICT Manager - Smart System & Heat | akira.kobayashi@eti.co.uk | It would be one of the very important activity for infrastructure building. I would like to be informed if further information will be available. |
| Euan Davidson | Smarter Grid Solutions | Head of Power Systems | edavidson@smartergridsolutions.com | Good project. Clear narrative needed on why NIC funding is required. Could use pac world survey to as a wider industry support of technical challenges. |
| Mark Stockton | Sse | | Mark.stockton@sse.com | Very positive and definitely a worthwhile project to bring together the pieces of the jigsaw. There are some key challenges to address to ensure that potential risky areas in the standardisation and interoperability but we need to show the value of the technology or we will never change. |
| Danny Lyonette | Abb | | Danny.lyonette@gb.abb.com | Very good |
| Rannveig Loken | Statnett | Protection and control manager | Rannveig.loken@statnett.no | |
| Steve read | ProTech Consulting Ltd | principal | Steve.w.read@extra.co.nz | I am most interested I the Fitness presentation as I has a lot of relevance to a coming initiative in the NZ grid |
| Mohammed Tageldin | ABB | Senior protection systems engineer | Mohammed.tageldin@gb.abb.com | Good. |
| Jorge Cardenas | General Electric | Application Mgr | Jorge.cardenas@ge.com | |
| Graham Dollin | Production Software Limited | Managing Director | G.dollin@prodssoft.co.nz | |
| Dinesh Ravana Gurusinhe | RTDS Technologies Inc. | Simulation Specialist | dinesh@rtds.com | |
| Barry Gilbert | ESB International (ESBI) | Consultant control & protection HV standards | Barry.gilbert@esbi.ie | |
| Dave dolezlek | Sel | International technical director | Dave@selinc.com | |
| Patricia Hortoh | Alstom Grid | Product Manager | Patricia.horton@alstom.com | |
| Robert Groarke | Sen Ireland | Scada Manager | Robert.groarke@esb.ie | |
| Markus Lenzin | Swissgrid AG | Head of Substation Technology | Markus.lenzin@swissgrid.ch | You are facing actual and upcoming requirements with this program. Let it get done! |
| Hans-Jürgen Gruber | TenneT TSO GmbH | | hans-juergen.gruber@tennet.eu | we want to install an NCIT in our grid, too, so it would be great if we could share some experiences. |
| Jan Skogeby | ABB | Area sales manager | Jan.skogeby@se.abb.com | Very interesting. Please keep me informed. |

Figure 27 PAC World Stakeholder Feedback

D.2. Partner Selection

FITNESS proposal development team undertook a detailed partner selection process to elect project partners based on quality of technical solutions offered, previous experience and cost for delivery of solutions through a two staged partner selection process:

1. All interested suppliers submitted a proposal based on a project scope provided by SPEN to highlight compliance with technology requirements, and contribution to key areas of innovation. After careful evaluation of all proposals from ALSTOM, ABB, SIEMENS, SEL, ZIV, Ingeteam and Alcatel-Lucent, five of the suppliers were selected for the second stage of the proposal review.
2. All suppliers completed partner selection criteria forms supplied by SPEN, which were then assessed against an evaluation criteria and weightings presented in Table 11. The final evaluation scores are presented in Table 12. All aforementioned documents are available on request for review.

| Criteria | Weights |
|---|---------|
| Technical Scope and Innovation Strategies (Quality) | 35 |
| Consultancy (Quality) | 10 |
| Costs and Partner Contribution (Price) | 20 |
| Resource Availability (Quality) | 10 |
| Multiple-Partnership (Quality) | 15 |
| Knowledge Dissemination (Quality) | 10 |

Table 11 Evaluation Criteria and Weightings

| Manufacturer | Quality (80%) | Price Score (20%) | Quality Score | Total Score |
|--------------|---------------|-------------------|---------------|-------------|
| | | | | |

Table 12 Final Evaluation Scores

D.3. Value for Money

SPEN endeavours to deliver value for money for UK customers through FITNESS. FITNESS endeavours to bring innovative digital substation solutions to business-as-usual deployment in the RIIO T2 period for GB TOs and thus enabling TOs to save on asset investment at the same time relieving constraints.

SPEN will follow SPTs procurement and legal policies to ensure contractual agreements between partners are placed after decision on funding request has been made following established processes and project milestone payments are aligned with project plan and SDRCs.

SPEN has reviewed cost-estimations from various partners to ensure FITNESS benefits from discounted rates and in kind contributions from partners in terms of material and labour. These estimations have been further scrutinised to ensure appropriate levels of risk mitigation contingency and to avoid cost overruns to our best estimate.

SPEN encourages UK SMEs e.g. Synaptec to bring to market their innovative technologies and ideas through FITNESS. Synaptec will benefit from project FITNESS by working with OEMs e.g. ALSTOM and ABB in realising potential applications for distributed sensing technology.

Appendix E: Project Plan

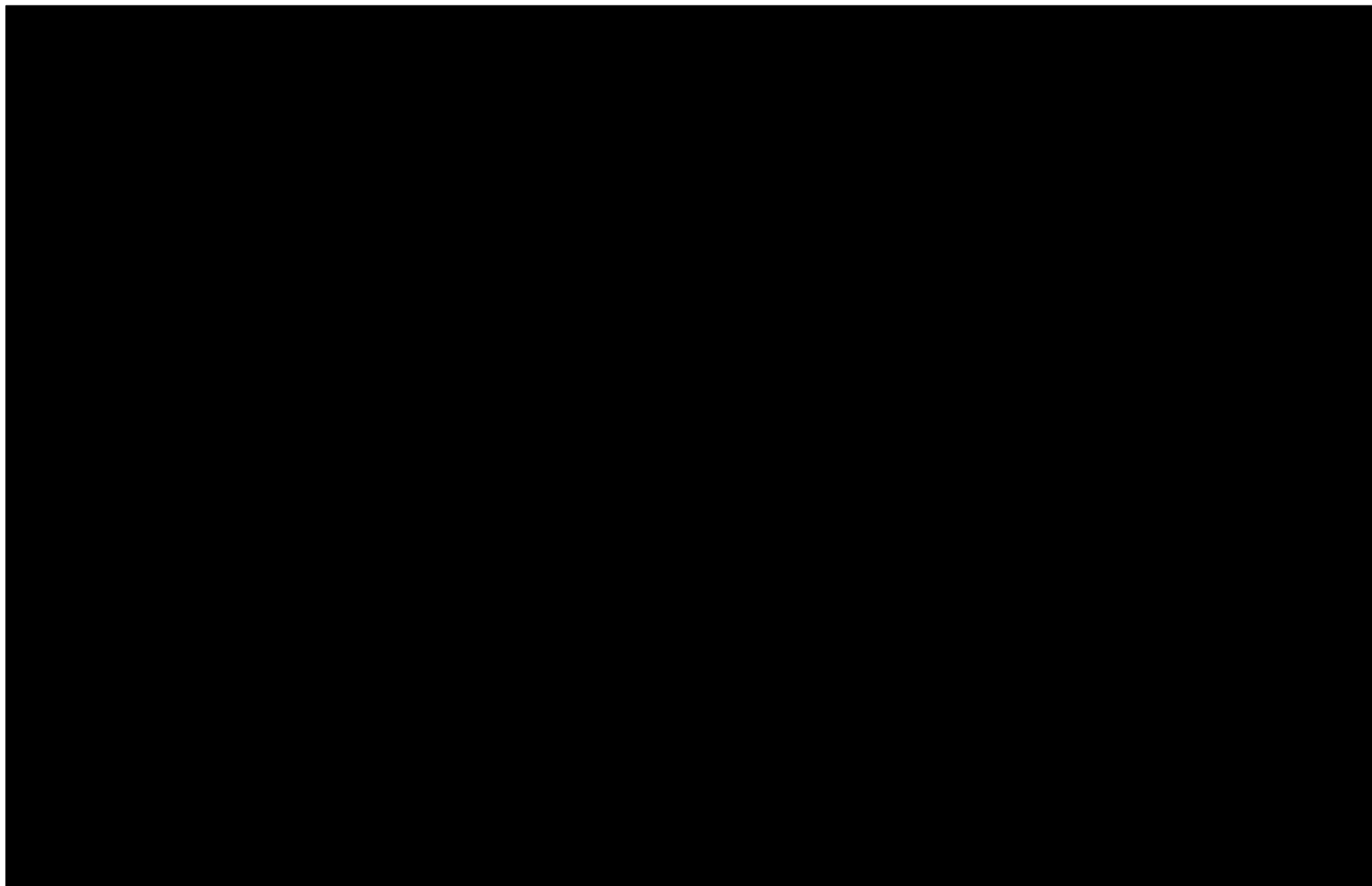



Appendix F: Risk Register and Contingency Plan

The risk register presented is a summary of a more detailed document, available on request.

| Key for New Technology Risk Register | | | | | | | |
|--------------------------------------|----------|-------------------------------|-------------|----------------|-------------|-------------------|-----------------------------|
| Financial impact | | Probability of risk occurring | | Overall Impact | | Reputation Impact | |
| Score | £k | Score | Probability | Score | Impact | Score | Impact |
| 1 | <10 | 1 | V. Low | 0-9 | Low Risk | 1 | Minor: Department awareness |
| 2 | 10-100 | 2 | Low | 10-29 | Medium Risk | 2 | Medium: Company awareness |
| 3 | 100-500 | 3 | Medium | 30-40 | High Risk | 3 | Major: National awareness |
| 4 | 500-1000 | 4 | High | | | | |
| 5 | >1000 | 5 | V. High | | | | |

| General Project Risks | | | | | | | | |
|---|---|--|--|-------------------|------------------------|-------------------------|---------------------|--|
| Risk No. | Issue | Risk Description | Potential Impact | Inherent Risk | | | | Control Measure(s) |
| | | | | Probability (1-5) | Financial Impact (1-5) | Reputation Impact (1-3) | Overall Risk (1-40) | |
| 1. General Risk | | | | | | | | |
| 1 | Contractual agreements timing | Contractual agreements are complex due to the number of partners and the involvement of competing vendors, possibly generating delays | Time is lost in the first months | 3 | 1 | 2 | 9 | Precedent agreements under NIC framework between project leader and one of the suppliers |
| 2 | Partnership between competing vendors | Competing vendors restrict the information exchange between each other by fear of IPR leakage | Reduced effectiveness of the exchanges, refraining to meet the expected outcome and leading to less complete deliverables | 3 | 3 | 2 | 15 | Stronger lead taken by the utilities to ensure the data and information critical for the project is exchanged and provided in the deliverables. Project contractual agreements will provide security against the same. |
| Summative Risk Scores | | | | 6 | 4 | 4 | 24 | |
| 2. Technology Assessment: see Work Package Risk Register | | | | | | | | |
| 3. Installation Phase: | | | | | | | | |
| 3 | Outage planning for substation works and installation | The installation of the equipment is dependent on the operational planning: the outage schedule is already decided and is well into the project; unforeseen events affecting the outage schedule may delay the outcome | Reduced time for live operation or delay in closing the project | 3 | 2 | 2 | 12 | Installation window already chosen, with some margin for slippage. Agreement with vendors to show in schedule. More than one candidate substation selected. |
| 4 | FITNESS delaying or extending the planned outage | FITNESS on-site work time extends beyond the outage window | High financial aspect in relation to operations (and possible impact on general outage planning of the area) | 3 | 5 | 2 | 21 | Extensive pre-commissioning tests to reduce the installation complexity. Prioritization of the tasks requiring an outage |
| 5 | Acquaintance to new equipment | Necessity for utilities to install new equipment that is unfamiliar to chief contractors | Potential delays and mistakes (configuration) in the installation | 3 | 3 | 2 | 15 | Project partners to provide support in terms of training, initial setup in offline environment, supervision of installation. |
| Summative Risk Scores | | | | 9 | 10 | 6 | 48 | |
| 4. Operation, Maintenance and Service: | | | | | | | | |
| 6 | Spurious tripping | Introduction of a new protection equipment may lead to tripping in the early stages of live operation | Disturbance to normal operation of the system | 3 | 3 | 3 | 18 | Extra tests performed prior to installation. When possible, operational planning will take into account of higher probability of outage. |
| 7 | Failure of new equipment | New equipment - never used in real grid conditions previously - not meeting the performance requirements | Targets for the demonstrations are not met | 3 | 3 | 2 | 15 | The equipment will be tested extensively in lab environment, and used first in non-tripping mode |
| 8 | Cost of on-site resolution of problems | The cost of resolving problems on-site is typically 10 times higher than in the test lab environment | Substantial increase in costs if issues observed once installation is completed | 2 | 3 | 3 | 12 | The equipment will be tested extensively in test environment. Pre-deployment setup will be performed in the test environment. |
| Summative Risk Scores | | | | 8 | 9 | 8 | 45 | |
| 5. Health, Safety and Environmental Risks (HSE): | | | | | | | | |
| 9 | New equipment | Lack of experience and knowledge regarding new pieces of equipment | Health and safety risks present as a result of lack of experience. Inefficient working, errors and high costs could result | 2 | 1 | 1 | 4 | Manufacturers to provide support in terms of training, and supervision of installationsolutions. However as conventional equipment will also be installed in parallel H&S guidance will be provided to all site contractors. Site engineers will need to respect all H&S standards set out for work on site. |
| Summative Risk Scores | | | | 2 | 1 | 1 | 4 | |

| Work Package Specific Risks | | | | | | | | |
|---|--|--|--|-------------------|------------------------|-------------------------|---------------------|---|
| Risk No. | Issue | Risk Description | Potential Impact | Inherent Risk | | | | Control Measure(s) |
| | | | | Probability (1-5) | Financial Impact (1-5) | Reputation Impact (1-3) | Overall Risk (1-40) | |
| WP1: Substation design | | | | | | | | |
| 10 | Engineering design of NCITs and Merging Units | Project partners need to work closely with site contractors and facilitate engineering design for installation of NCITs and Merging Units. This may lead to conflicting ideas. | Delay in engineering design and issues over time required for installation will affect site work and successful delivery of the project. | 2 | 4 | 2 | 12 | Early engagement between project partners and site contractors required to reach agreement on engineering design aspects of substation design. A clear division of tasks defined by SP Transmission and FITNESS delivery team should give each contractor and vendor an idea of the key deliverables during design phase. |
| 11 | Choice of Substation | FITNESS will be demonstrated parallel to an existing replacement planned in business as usual. Delays in delivery of planned substation will delay design of FITNESS solution. | Delay in substation engineering design due to lack of availability of conventional design plan. Less time in live operational experience | 2 | 3 | 2 | 10 | Substation designs are well planned and designed by SP Transmission. SPT and primary contractors IEC follow a strict delivery schedule to avoid negative financial impact to the business. FITNESS will ensure its demonstration plans align with SPT substation plans and engineering design requirements are supplemented on time. |
| Summative Risk Scores | | | | 2 | 4 | 2 | 12 | |
| WP2: Substation performance | | | | | | | | |
| 12 | Maturity of the NCIT(non conventional instrument transformers) | Even if the technology is promising in terms of achieved performance, the reliability and robustness of the instruments is insufficient | Ambitions of the demonstration are reduced, or delays in closing the project. | 3 | 3 | 2 | 15 | Involvement of two project partners in this project significantly reduces the risk. As interoperability and NCIT concept can still be proven using manufacturer A or B NCITs. |
| 13 | Measurement quality | Targets in terms of accuracy, bandwidth, dynamic range, are not met | Superior performance in terms of measurement quality cannot be demonstrated | 3 | 2 | 2 | 12 | There is experience available from other trials internationally which could help manufacturers assess the problem and improve the product within project duration. Competant R&D teams are available from both manufacturers to make necessary modifications |
| 14 | Interoperability | The test procedure reveals that interoperability is not achieved fully between multi vendor equipment. | One of the major project goals is not achieved fully in demonstrating interoperability. | 4 | 2 | 2 | 16 | Interoperability tested extensively in test environment prior to installation. |
| 15 | Outage Schedule Agreements | Project partners need to deliver the project within outage schedules already planned for replacements on the selected site. | Extending outage schedule will require long approval process and negatively impact delivery of the conventional substation. This will not be allowed by SPT business | 1 | 4 | 3 | 7 | Project plan needs to take into account outage schedules planned for the conventional replacement work. As digital substations secondary equipment are offline tested, installation commissioning of the secondary does not require much outage. After NCIT and MU installation along with conventional only digital fibre signal testing is required and all activities are predicted to be completed with in 3-5 days. |
| 16 | Live Tripping | Closed loop tripping is required to complete end to end testing of digital substations. The operational risk of false tripping can cause unplanned outage. | Unplanned outage due to new equipment false tripping. | 1 | 3 | 3 | 6 | Sufficient offline testing under various fault and non-fault conditions should mitigate the risk of false tripping on site. |
| 17 | Distributed Sensing technology | Distributed sensing technology is currently being developed under a NIA project and has not previously been trialled in a live substation environment. | Delay in completion and availability of distributed sensing technology will lead to failure in delivery of this workstream. | 2 | 2 | 2 | 8 | Delivery target is significantly earlier than the target for substation installation (2018). The minimum deliverable for this workstream will then be testing the distributed sensing technology in an offline environment. |
| 18 | Distributed Sensing technology interoperability with process bus | Distributed sensing technology will develop an interface to the process bus architecture. | Failure to comply with standards for process bus will lead to failure in demonstrating interoperability. | 2 | 2 | 2 | 8 | The output of this technology then needs to be converted to a more suitable format to be interfaced to the information and/or process bus. |
| Summative Risk Scores | | | | 12 | 14 | 12 | 56 | |
| WP3: Substation-to-System Lab & Live Performance Testing | | | | | | | | |
| 19 | Insufficient scope/clarity of existing standards | The existing standards do not cover the measurement chain from end to end in a satisfactory manner for the project objectives | Interoperability is not fully guaranteed | 3 | 1 | 2 | 9 | Pre-screening of maturity of standards and alignment with ENA and ETSI recommendations for standards for SMART Grids. Identification of areas of further improvements to standards internationally. Involvement of University of Manchester and working groups will enable better definition of standards. For the project: agreement on transparent application of a 'good practice'. The resolution suggested by international standards working groups has to be accepted and adopted by project partners. |
| 20 | Compliance of equipment to standards | Not all equipment from involved manufacturers does comply fully with standards | Demonstration of interoperability for integration of substation and system not successful | 2 | 3 | 2 | 10 | Project partners will upgrade their individual firmwares and softwares to align and be fully compliant with the standard. The cost for the same will be borne by the concerned project partner. |
| 21 | External communication network | External communication network is not fit for purpose | Upgrades required to communication network, delays in the demonstration | 2 | 3 | 2 | 10 | Communication links need to be checked early in project delivery stage and all necessary communication requirements will be communicated and agreed with SPEN IT and Security department. |
| 22 | Fault Management | Enhancement of existing VISOR's SDM functionality do not enable sufficiently accurate fault location using phasors. | Fault location using phasors would not be proven for BaU. | 1 | 2 | 2 | 4 | Use of conventional comtrade files instead of phasors can mitigate this risk by demonstrating fault management from process bus, thus still proving process bus data quality. |
| 23 | Harmonics Mapping | In order to demonstrate harmonics mapping we need sufficient data from multiple distributed locations. | Harmonics mapping will not demonstrate and/or identify sources of harmonics. | 3 | 2 | 1 | 9 | Extend functionality to all available RPV311 in SPEN system by firmware upgrade for more data. Simulation or replay of harmonics data into the software can prove the functionality and the concept of harmonics mapping. The robustness and quality of the application can not be proven through this method but the concept and software reliability can be checked using simulated data. |
| Summative Risk Scores | | | | 7 | 7 | 6 | 29 | |
| WP4: Security | | | | | | | | |
| 24 | Cyber security | Enabling remote access of substation protection and monitoring capability introduces cyber security risk | Remote access to substations can result in cyber attacks | 3 | 2 | 2 | 12 | Early involvement of SPEN IT security experts and project partners to create a risk assessment tool to assess security issues associated with each equipment and access protocols will mitigate this risk. Pen testers should be deployed to check security robustness of remote access. |
| 25 | Cyber security in WA control | The IEEE C37.118 standard for synchrophasor streaming was not originally intended for cyber-secure control schemes. | Intrusion may result in unwanted control actions e.g. reactor switching, and voltage changes control schemes. | 2 | 2 | 3 | 10 | Cyber security risk is assessed. If risk deemed too high for control action, demonstrations will not include actuation of control, but will list actions to resolve risk. In particular, use of IEC 61850-90-5 compared with C37.118. |
| Summative Risk Scores | | | | 5 | 4 | 5 | 22 | |

Appendix G: Base Case Value Derivation

G.1 Value Proposition

The value of FITNESS to transmission and distribution network owners comes from two key areas:

- Reduction in substation costs;
- Improved operational flexibility.

While the value to the SO and the customer comes from:

- Reduction in network constraints, constraint payments, balancing and grid services.

There are additional value streams from FITNESS to the GB system as a whole. These include:

- Improving substation safety;
- Reducing carbon and environmental impact of substations;
- Enabling flexibility in protection automation solutions, and adaptive protection.
- Enabling improved system visibility, diagnostics and operation, through provision of high quality current and voltage measurements.

G.2 Base Case

Overview of Existing Substation Design

Transmission substations consist of primary plant, such as transformers, switching equipment and instrument transformers and low voltage secondary equipment such as protection, monitoring and control equipment. The secondary equipment is typically connected to the primary equipment via copper wire multi-core cables. The practice followed by Transmission Owners (TOs) for substation design, replacement and modernisation has evolved over years and has always been based on the best proven technology available at that point in time. For example, substation automation systems (SAS) have evolved over the past 40-50 years from hard-wired mimic/control boards to mimic/control boards in conjunction with Remote Terminal Units (RTUs) to Substation Control Systems (SCS) with a substation computer.

As the output of conventional CTs and VTs are analogue amperes and volts, the protection and control equipment to which they are connected are traditionally provided with analogue inputs. The functionality of protection relays has been greatly increased by the use of numeric microprocessor technology. However, to allow connection to conventional CTs and VTs, each numeric protection relay is provided with interposing transformers and Analogue to Digital Converters (ADC). Circuit breaker trip coils require a DC voltage for operation. Even the latest numeric protection relays, when issuing a trip command, usually operate a trip contact in the relay to switch the DC voltage on to the circuit breaker trip coil. Copper wire multicore cables are therefore also used for this function.

In addition to the copper wire multicore cables required for CT and VT analogue inputs and circuit breaker control, copper wire connections are required for status and alarm signals. The current design of substations, based on conventional CTs and VTs, have been optimised for the latest numeric multifunction protection relays and substation control equipment with copper wire connections.

In terms of standardisation and interoperability, the latest substations on the SPT network incorporate the IEC 61850 8-1 standard for the Station Bus. This standard defines means for communication between intelligent electronic devices (IEDs) and the station control system, and enables a level of vendor interoperability and easier modification and extension of secondary systems. In this context, interoperability means the capability of two or more IEDs from one or several vendors to exchange information and to use it in the performance of their functions and for correct co-operation²⁸.

Conventionally, analogue current and voltage instrument transformer outputs are typically standardised at 1A and 110V respectively, received by protection relays rated for these signal levels. Different manufacturers’ relays connect to these standard analogue signals through internal instrument transformers. Connections are point to point between devices, so interoperability at this process level is not required in the conventional substation.

Substation Costs

Substation costs that are related to substation functionality and operation include primary and secondary equipment, cabling, and engineering and commissioning. Engineering and commissioning costs are reduced by maximising the amount of relay testing at the factory and minimising the amount of testing required on-site. Substation costs related to civil works, project management and design in new build or replacements, require large investment, and are time consuming, but do not directly add to the functionality or operation of the substation. A significant contribution to the minimisation of these costs is through standardisation of design, equipment and procedures.

Cost breakdowns as a percentage of total substation costs are presented in the Table 13.

| Category | Description | Percentage Costs | Environmental Impact |
|---|---|------------------|----------------------|
| Substation works related to substation functionality and operation. | Substation cabling costs | 4% | Y |
| | Engineering and Commissioning | 8% | Y |
| | Primary Equipment | 42% | Y |
| | Secondary Equipment | 16% | Y |
| Substation works unrelated to substation functionality and operation. | Civil Works <ul style="list-style-type: none"> • Foundations/Support Structures • Trenches and Ducts for cables • Control Building | 16% | Y |
| | Project Management and Design of substations | 14% | N |

Table 13 Substation Costs Breakdown

Operational Flexibility

It is recognised that increasing use of power electronic interfaces to interconnections, generation and load, leads to reduced inertia and fault currents (short circuit level), as highlighted in Figure 28 and Figure 29 respectively.

²⁸ ABB - IEC 61850 – Interoperability: <http://www.abb.co.uk/cawp/seitp202/c1256a8c00499292c1256d41003831cc.aspx>

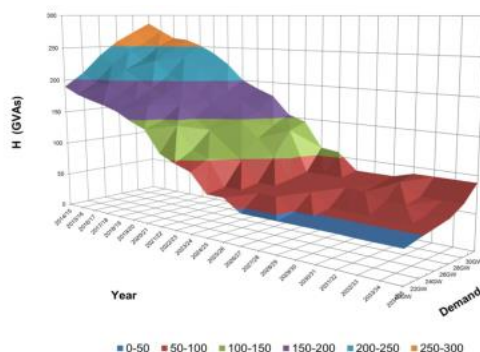

Figure 28 GB System Inertia Changes for Gone Green Scenario²⁹

System inertia is a key measure of how strong the system is in response to changes in frequency. Low system inertia increases the risk of rapid frequency changes following severe faults or loss of load or generation, leading to system instability. It is important to estimate and monitor the system to ensure sufficient margins in order to avoid instability are maintained. Innovation work is trialling methods to accelerate frequency response capability (see Appendix H).

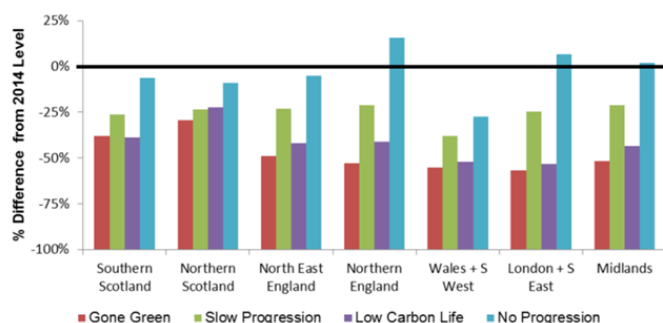

Figure 29 Minimum Short Circuit Level 2024/25 relative to 2014/15²⁹

Fault level is a measure of system strength in response to voltage variations and faults. A high fault level indicates a) that the voltage changes are small in response to small disturbances on the network, as per the performance requirements in the Grid Code and NETS SQSS, and b) that large current will flow into a fault, used by protection devices. Power quality, which is related to system strength, affects the performance of loads connected to the system and is an important consideration for system operation. As fault levels fall, it becomes more difficult to differentiate between fault current and load current. This makes it difficult for protection systems to detect faults, and could lead to extended tripping times during periods of low fault level, especially for backup protection.

To properly understand and mitigate the impact generation changes on these issues, it is necessary to install new substation monitoring and control equipment. This installation of this equipment requires system outages, which must be included as part of on-going asset management programmes. GB transmission assets are aging, and of an asset base of around 10,000 units, around 10% are deemed to be at end of life, with a further 5% reported with material deterioration, as presented in Figure 30. As a result of the aging

²⁹ System Operability Framework: <http://www2.nationalgrid.com/UK/Industry-information/Future-of-Energy/System-Operability-Framework/>

asset base, significant asset investment will be required over the next price control review periods, RIIO T2 and RIIO T3. It is important that the asset replacement incorporates modernisation of the monitoring and control equipment for the needs described, rather than simply replacing existing capability.

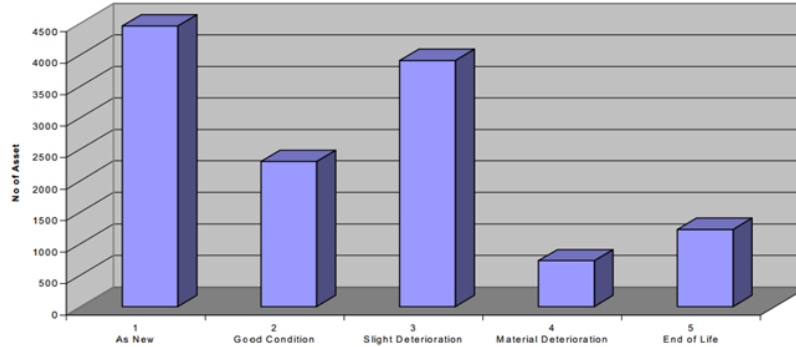

Figure 30 SPEN Asset Health

All assets on the transmission network require maintenance and eventually replacement. To carry out maintenance of these systems, the network has to undertake outages, which impact on the rest of the system and can cause constraints. Planned outages are managed years in advance to factor in routine maintenance. Due to outage requirements and system access constraints, the current achievable rate of replacement for protection and control systems is about 5% per annum. It therefore takes around 20 years to complete a whole cycle of replacements. The typical asset life of these systems is between 10 and 15 years due to the fast pace of change in technology and power system needs. This makes some systems obsolete and technical support may no longer be available. The changes to system inertia and fault level, coupled with the increasing amount of asset modernisation and replacement, challenges many of the business-as-usual practices in terms managing asset investment programmes.

Typical outage durations for different works are outlined in Table 14.

| Description | Conventional Outage Duration per Bay | FITNESS Outage Duration per Bay |
|--|--------------------------------------|---------------------------------|
| Modernisation | 6 weeks | 2 weeks |
| Replacement | 40 weeks | 35 weeks |
| Addition of monitoring and control equipment | 1 - 2 days | 0 days |
| Repairs and maintenance works | 0.5 - 2days | 0.5 days |

Table 14 Comparison of Conventional and FITNESS Outage Requirements

It will not be possible to install the required number of monitoring and control equipment to cater for system inertia and fault level issues, without taking significantly more outages. In addition, the monitoring and control equipment may require high bandwidth CTs, and conventional devices will require longer outages for installation.

Outages

At present, the impact of secondary system reinforcement and modernisation is reduced by carrying out this work at the same time as the outage scheduled for the associated primary plant. Outages are scheduled for up to 7 years in advance, over-run of one outage for maintenance can have a significant knock-on effect on others, and there is a risk that the schedule for modernisations and new connections is extended, resulting in, new

connections being substantially delayed, and modernisation of assets delayed by months or years. This would lead to increased failure rates and delays to circuit uprating resulting in increasing constraints.

Substation Safety

Conventional CTs and VTs are an integral part of the power system, as they are used for protection, metering and control applications. They do however carry an inherent safety and environmental risk as they are filled with oil or gas, are large in size and mass, and require copper wire connections across the substation to connect to the secondary equipment. There is also an inherent danger posed by an open circuited CT. Poor weather conditions may lead to moisture ingress, compromising the insulation of the CTs. This could result in a catastrophic failure of the CT, which would be a serious safety concern for operators and could also damage critical primary plant. Working practices are used to effectively mitigate these risks, but often at the expense of cost and outage time. In addition, there are a number of safety implications related to the construction of substations, amount of time spent on site, and time travelling to and from site.

Carbon and Environment

Copper and oil usage in the substation.

There are several carbon and environmental concerns with the existing substation design, in terms of high usage oil, gas and copper in conventional instrument transformers and cabling.

Constraining wind and rebalancing with gas.

National Grid, as the SO, balances supply and demand for electrical power through the Balancing Mechanism, as discussed in this proposal. When the SO asks a generator to reduce output, they manage the shortfall in generation by buying energy from the market from another generator elsewhere on the network. Low carbon generators, such as windfarms, tend to be located in weaker areas of the grid and are constrained, while the shortfall in generation is typically made up by fossil fuel generators, such as gas. The National Grid Monthly Balancing Services Summary (MBSS 2014/15)³⁰ shows £62.56M in constraint payments to wind generators, which is 60% of constraint costs paid by National Grid, and 21% of the net constraint/rebalancing costs, while 87% of rebalancing payments were made to gas generators. The carbon and environmental impact of reducing output of low carbon generators in favour of fossil fuel generators as a result of network constraints is clear.

The base case levels of constraints placed on wind generation were calculated based on the typical outage time required to complete secondary system modernisation and replacement works. The average emissions of electricity generation by long term marginal plant are 430,000g of CO₂ per MWh.

³⁰ National Grid Monthly Balancing Services Summary (MBSS March 2015, FY2014-2015):
<http://www2.nationalgrid.com/UK/Industry-information/Electricity-transmission-operational-data/Report-explorer/Services-Reports/>

G.3 Net Benefits

The solutions enabled and benefits realised through FITNESS have been described elsewhere in the proposal. The following is supplementary information on the network capacity released through FITNESS as outlined in the NIC Full Submission spreadsheet.

Overview

FITNESS enables the release of network capacity by:

1. Improving network availability through reduction in outages;
2. Accelerating load-related reinforcement
3. Easy integration of monitoring and control technologies and applications to improve system visibility and allow for an increase in system operability limits (headroom) and address risks such as inertia-related frequency disturbance without capping the total system non-synchronous penetration.

Only the first of these issues is quantified in the FITNESS benefit analysis, but the project is designed to deliver in all three areas.

To carry out the analysis, the following base case assumptions were made:

- Average price of action: £50/MWh;
- Average price of additional capacity: £34k/MW.

Reduced Substation Costs

FITNESS can realise a 12% reduction in substation bay new build costs, and a 9.4% reduction in bay replacement costs. As discussed, substation bay costs include civil works, project management and design, cabling, engineering and commissioning, primary and secondary equipment, safety risks, and ENS penalty risks. [REDACTED]

[REDACTED] The reduction in costs means the TO can reduce asset investment while releasing the same capacity (adding extra bays).

Improved Operational Flexibility

Implementation and roll-out of low carbon technologies and innovations such as those demonstrated on the EFCC NIC project to address system inertia issues could, if successful, realise savings of £150-200m by 2020.³¹ Similarly, on the VISOR NIC project, capacity improvement based on improved observability was estimated at about 50MW. However, studies on simplified models as part of the Smart Transmission Zone NIA project, suggest a variable uplift, higher in high wind scenarios, indicating that about 400MW could be released through wide area control of HVDC, constraint relief and a mix of other control and monitoring approaches. EFCC indicated that a 2-3-year implementation period would be required for rollout. However, one of the lessons learned from both VISOR and EFCC is that implementation of the infrastructure can be significantly delayed by 1-2 years due to not being able to get planned outages. FITNESS accelerates roll-out of these types of innovations and realisation of the benefits, by enabling faster and easier implementation of core infrastructure such PMUs, and robust data infrastructures.

³¹ National Grid Electricity Transmission (NGET) Enhanced Frequency Control Capability (EFCC) NIC Full Submission Proforma: <https://www.ofgem.gov.uk/ofgem-publications/91433/elecnicfullsubmissionproformaefccsubmission.pdf>

There is a further benefit in accelerating the connection of new generation, especially wind, and controlling it within network constraints. The findings of the Angle Constraint Angle Management (ACAM) IFI³² project showed that a ‘Connect and Manage’ approach could enable 27-74% more capacity to be added at the studied wind farm locations using grid-sensitive wide area control, compared to the ‘Fit and Forget’ locally controlled unconstrained connection approach. These benefits are possible with conventional technology, but FITNESS accelerates integration of wide area control as the required infrastructure becomes a standard part of substation design, rather than a customised solution for every case. Achieving the business-as-usual transmission asset plan is challenging in the outage windows available. Reduced outage requirements make the asset plan more achievable with less risk of delay. Cost and time savings on-site are substantial, with the flexible digital design, as an increased amount of testing and commissioning can be carried out in the factory. Technical issues or challenges that arise during factory testing and commissioning, can be resolved more economically than those that arise on-site. Requiring shorter outage windows significantly reduces the risk of over-run, as the scheme can be fully tested prior to site work starting, and leads to increased operational flexibility. A comparison of lifecycle costs of conventional vs digital substations is shown in Figure 31.

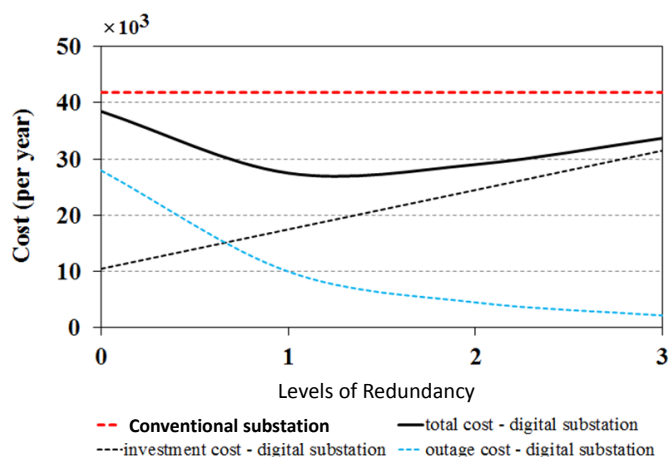

Figure 31 Life cycle costs of Conventional vs Digital substation

Reduced Outages, Constraint Payments, Balancing and Grid Services

FITNESS will realise an average reduction in network constraints of 3.3-5.0% per year up until 2050, based on the different uptake scenarios. This will benefit the SO in reduced constraint payments, and the TO in increased network availability.

A summary of capacity released as a function of the uptake scenarios is outlined in Table 15. It would require investment of between £61.3m and £205.9m, to release the same amount of network capacity using conventional methods.

| FITNESS Scenarios | Future Energy Scenarios | | |
|-------------------|-------------------------|------------------|-----------------|
| | Gone Green | Slow Progression | Low Carbon Life |
| Fully Digital | ██████████ | ██████████ | ██████████ |
| Partial Uptake | ██████████ | ██████████ | ██████████ |

Table 15 Cumulative Sum of Released Network Capacity up to 2050

³² SPEN ACAM project: <http://www.smarternetworks.org/Project.aspx?ProjectID=585>

Improved Safety

FITNESS will realise an improvement in substation safety by replacing conventional CTs and VTs with NCITs, replacing copper wiring with fibre optic and reducing time spent on site.

Reduced Carbon and Environmental Impact

The projections for the reduction in levels of wind constraint and the subsequent CO₂ savings are based on the reduction in hours of outage required by primary plant to complete the work, and the projected future wind generation taken from National Grid FES. In the FITNESS FD uptake scenario, it is estimated that a 5% increase in the amount of carbon being offset due to reduction in constraints on the network, is achievable. For the FITNESS PU scenario the same value is estimated at 4%. The process of extracting copper and making copper wiring produces high level of CO₂, and the digital substation solution enables an 80% in the use of copper hardwiring. It has been estimated that the baseline level of CO₂ due to copper use per substation is 70 tonnes, this will be reduced to 20 tonnes under FITNESS, equating to a 71% reduction.

G.4 Post-FITNESS Roll-out

As discussed in detail in Section 2, FITNESS will trial methods for managing the substation secondary system and enabling new low carbon technology to be integrated more easily into substation design in a standard, optimal way. The methods include:

- Flexible, interoperable and reliable digital substation architecture design;
- Standardisation of substation monitoring, control and automation through a digital communications based optimum architecture;
- Measurement using NCITs.

The costs associated with these methods have been outlined in the Full Submission Spreadsheet. Developments, demonstrations and knowledge gained through FITNESS will lead to a reduction in costs associated with the method in the post-project roll-out due to:

- Improvements in the TRL of equipment, such as MUs, NCITs, SCUs etc. – Higher TRL enables consistent, uniform discussions on technical maturity in terms of roll-out.
- Production of technical specifications and design guides – Lessons learned during design process will lead to optimisation of future installations, reduced consultant, contractor design costs, and reduced civil and labour costs.
- Successful demonstration of the full value chain of the technology in a live substation on the GB system for the first time - FITNESS will open up the market to suppliers of IEC 61850 equipment and generate increased levels of competition.

In addition, equipment used in the FITNESS demonstration, such as MUs, are required as the system is designed to operate in parallel with a conventional analogue system. Method costs associated with equipment will be reduced for post-project roll-out in new builds or full digital substations, through reduction in required equipment.

Appendix H: Links to Previous Innovation Funded Projects

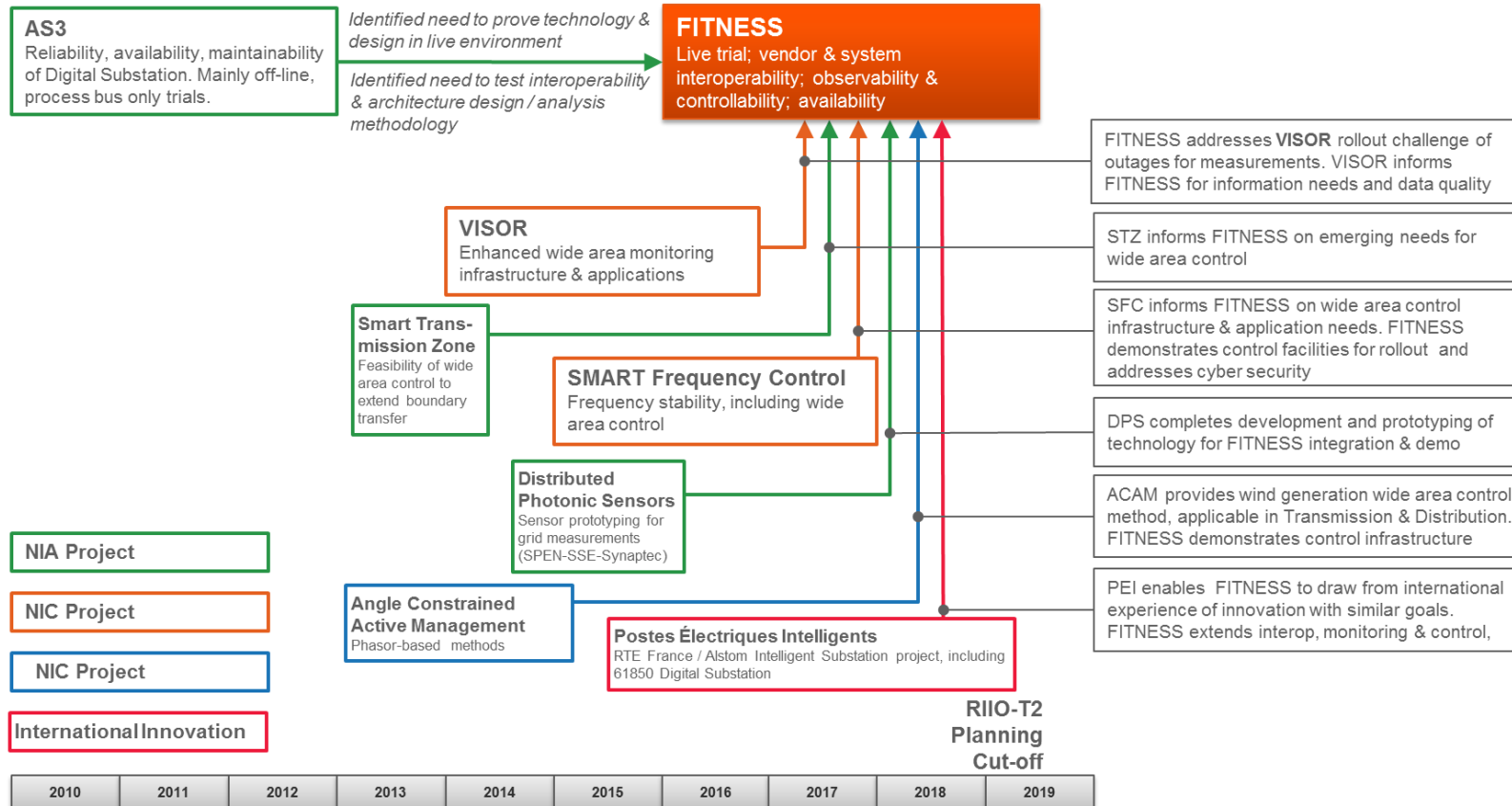

| | |
|---|---|
| <p>Architecture for Substation Secondary System (AS3)</p> <p>Licensee: National Grid Electricity Transmission</p> <p>Funding: IFI</p> | <p>AS3 was a collaborative IFI project between NGET and SPT to create new architectures for substation secondary systems by introducing new technologies, targeting a quicker and easier approach for the installation and replacement of protection and control equipment. The project reviewed policies and practices to identify and understand the whole life cycle issues for the existing protection and control systems. The outcome of the project was strategy documents for substation secondary systems and investigation of the new approach in parallel with existing systems with outputs disabled 'Piggy-back' trials with single vendor equipment. The project concluded with identification of issues and technical specifications for digital substations equipment. FITNESS will use learnings and architecture from AS3 in GB pilot digital substation demonstration and prove multi-vendor interoperability, and interoperability with WAMS system.</p> |
| <p>Visualisation of Real Time System Dynamics using Enhanced Monitoring (VISOR)</p> <p>Licensee: SP Transmission Ltd</p> <p>Funding: NIC</p> | <p>The SP Energy Networks VISOR project showcases the contribution that a real time Wide Area Monitoring System (WAMS) could make to improve the efficiency and security of the GB system in the near term. The creation of the VISOR WAMS requires the installation of new monitoring devices in in substations during the course of the project. By the nature of innovation projects, outages are not planned exclusively for their benefit, so the installations performed as part of an innovation project must be coordinated with outages planned for other reasons. This barrier is resolved with FITNESS solution, as it allows new monitoring devices to be connected to the process bus without the need for an outage. This will accelerate roll out of new monitoring and control solutions as part of the smart grid paradigm. The degree of benefit offered by any WAMS is dependent on the quality and availability of the measurements generated by sensors, the improved accuracy of non-conventional instrument transformers that are to be trialled in FITNESS would help enhance the benefits identified within the VISOR project.</p> |
| <p>Enhanced Frequency Control Capability (EFCC)</p> <p>Licensee: National Grid Electricity Transmission</p> <p>Funding: NIC</p> | <p>The NIC EFCC project addresses issue of reducing inertia leading to a need for much faster frequency response. The project includes an innovative wide area control system to trigger and co-ordinate rapid frequency response capabilities of wind farms, solar PV, energy storage and demand-side response. The EFCC control scheme requires a robust wide area control architecture and data quality, and FITNESS directly contributes to EFCC roll-out by:</p> <ul style="list-style-type: none"> • Implementation of substation-based Regional Aggregation function to validate and processing of measured data. FITNESS provides more easily accessible data, higher quality, and distributed sources directly in the substation. • Demonstrating the control framework in a substation to deploy controls over IEC 61850 GOOSE. A standard design to implement EFCC controls, measuring the latency, and analysing cyber security issues greatly benefits EFCC roll-out. |
| <p>Smart Transmission Zone (STZ)</p> <p>Licensee: SP Transmission Ltd</p> <p>Funding: NIA</p> | <p>New approaches to increasing transmission boundary capability across the Scotland-England boundary were studied. The present intertripping mechanism will lose capability due to plant retireals. Novel control potential of Western Link HVDC and renewable generator control were investigated. STZ control algorithms could be applied using the flexible platform in FITNESS, given successful demonstration of data reliability, latency and cyber security.</p> |
| <p>Distributed Photonic Grid Instrumentation (DPGI)</p> <p>Licensee: SP Transmission Ltd</p> | <p>Development and testing of a prototype of distributed optical sensors. The sensors are passive, and multiple devices can connect over long distances using a single standard optical fibre, thus suitable for measurements outside the substation. They can be</p> |

| | |
|--|---|
| <p>Funding: NIA</p> | <p>applied to voltage, current, temperature, strain and vibration. An interrogator unit at the substation extracts the measured values.</p> <p>In FITNESS, the measurements are made available as sampled values in the process bus. The data will be captured by the PMU/disturbance recorder units, and the applicability trialed for the use cases fault location, disturbance recording and regional aggregation for phasor-based control. Further applications such as dynamic line rating are also feasible after successful demonstration.</p> |
| <p>Angle Constraint Active Management (ACAM) Licensee: SP Distribution Ltd Funding: IFI</p> | <p>Trial of an approach using phasor measurements for control of renewable generation in the 33kV Anglesey area. It proved the concept, and showed that the scheme could more easily adapt to changed topology (maintenance or fault) than other approaches. FITNESS demonstrates control infrastructure that would enable the approach to be rolled out at either transmission or distribution level.</p> |
| <p>Hybrid Line Protection by Rogowski Coil Licensee: National Grid Funding: IFI 2011/12</p> | <p>The project targets use of non-conventional current measurements at cable section ends of a hybrid line. FITNESS develops the concept with distributed optical sensors that do not need power supplies at the measurement location and are easily relayed to the substation via optical fibres, thus are easier to implement.</p> |
| <p>Protection & Control Roadmap Licensee: National Grid Funding: IFI 2011/12</p> | <p>A study project that identifies protection and control risks related to changing network conditions, and a need to adapt in near real time. Wide area monitoring, protection and control is identified as an enabling technology, and the need for reliable and secure infrastructure is raised. The FITNESS project addresses the need by a demonstration of feasible infrastructure in the substation.</p> |
| <p>Humber SmartZone Licensee: National Grid Funding: IFI/NIA 2011/17</p> | <p>Development of boundary rating enhancement methodologies, making use of new operational tripping and Wide Area Monitoring, Protection & Control (WAMPAC). Much of the innovation work on this project is at academic stage, and the rollout of the innovation will require a business-as-usual infrastructure for deployment. The FITNESS project will be an enabler for applying the Humber SmartZone innovation by delivering a flexible control infrastructure design and substation methodology, which can be used to implement the control schemes.</p> |

Appendix I: Organogram and Key Personnel

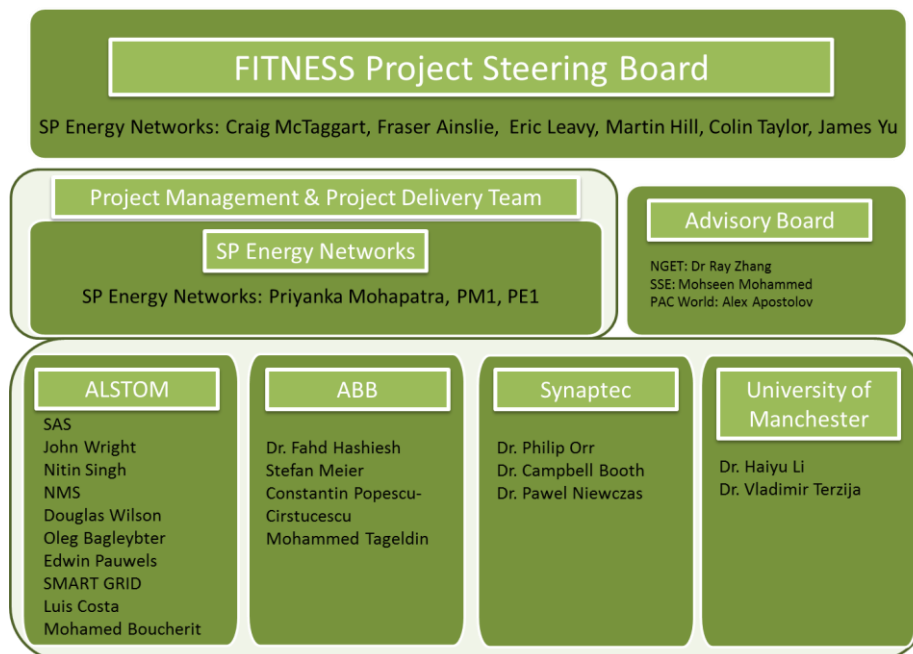

Figure 32 FITNESS Organogram



Craig McTaggart, Transmission Network Manager

Craig McTaggart is Transmission Network Manager under Network Planning and Regulation Group at SP Energy Networks. Craig is responsible for identifying, evaluating and managing the implementation of system-ready technology in SPT. He was previously responsible for the development and maintenance of Protection & Control Policy for the Transmission system and led the implementation of Substation Automation Systems based on IEC 61850 for Scottish Power Transmission. Craig will be a key stakeholder in project FITNESS and a member of the steering board providing his valuable guidance to FITNESS delivery team.



Fraser Ainslie, Engineering Design Manager (Networks)

Fraser Ainslie is the Engineering Design Manager at SP Energy Networks. As the head of engineering design team, he ensures that all network asset related projects for SP Manweb and SP Transmission are technically deliverable and commercially viable. His past experience comprises of transmission protection and engineering solutions for major projects. Fraser will be a key stakeholder in project FITNESS and a member of the steering board providing his valuable guidance to FITNESS delivery team.



Priyanka Mohapatra, Senior Project Manager

Priyanka Mohapatra is currently working as Senior Project Manager at SP Energy Networks and is the project lead for Project VISOR. She has previously worked as a software developer and project manager for real-time solutions for power substation automation at Siemens AG, Germany and as senior engineer and product owner at Siemens Protection Devices Limited, UK (global R&D). Priyanka is the proposal lead for project FITNESS.



John Wright, Head of Innovation & Business Development

John Wright has been involved from the inception of the project, and will continue in the role of consultant, providing continuity between the proposal and delivery stages. John is Head of Innovation and Business Development and Applications Engineering Manager in Alstom Grid's Substation Automation Systems business unit.



Douglas Wilson, Chief Scientist

Dr Douglas Wilson will take the role of Technical Lead for Network Management elements, and work with the technical team for delivery of wide area monitoring, control and central system integration. Douglas is also involved in delivery of the VISOR and EFCC projects. Douglas joined Psymetrix in 1998, and was Technical Director when the company was acquired by Alstom Grid in 2011.



Dr Luis Costa is the Smart Grid R&D Manager

Dr Luis Costa is with Alstom Grid Substation Automation Solutions, and will contribute to the FITNESS project with development of real-time monitoring and control related functions. He is involved in development for the French Poste Intelligent (Intelligent Substation) project.



Edwin Pauwels, Senior Project Manager

Edwin Pauwels has been involved in the FITNESS proposal development and will continue as Project Manager for the delivery of the project. He is also the Project Manager for Alstom's contribution to the EFCC project.



Dr Fahd Hashiesh, Head of Power Consulting

Dr Fahd Hashiesh has more than twenty years of diverse power systems experience covering high voltage switchgear assembling & testing, HV substation designs and projects management. He worked for ABB High Voltage, Egypt, as a Project Manager for turnkey HV substation projects. Fahd will provide technical expertise to FITNESS project..



Stefan Meier, ABB Digital Substation Solutions, Product Manager

Stefan Meier has been involved in the FITNESS project from the first discussions and concept proposals. He will continue to be involved in the project as technical consultant. Stefan is based in Switzerland and working for ABB since more than 15 years. He held several positions, from commissioning of substation automation systems, through technical support and project management



Constantin Popescu-Cirstucescu, Technology Manager

Constantin has over 19 years of experience in protection, control and communications systems. He holds a B.Sc. degree in Electrical Engineering and is an IET member since 2002. He was actively involved in key projects across the UK, being responsible for engineering standard bay solutions for National Grid and other customers. Constantin will provide technical and management guidance to project FITNESS.



Mohammed Tageldin, ABB Senior Protection System Engineer, ABB)

Mohammed has over 7 years of experience in delivering Engineering solutions of Substation Protection and control and Substation Automation Projects. He has a number of international publications in the area of Power system blackouts, wide area protection and Substation automation IEC61850 applications. Mohamed will be the overall technical lead from ABB for FITNESS.



Philip Orr, Managing Director

Dr Philip Orr has been involved since the planning stages of FITNESS, and will remain closely involved as joint Technical Lead for Distributed Sensing, focusing on the delivery of distributed measurement systems and their integration into the digital substation platform. Philip is presently technical lead on the Distributed Photonic Grid Instrumentation NIA project and will be part of delivery team for Synaptec for project FITNESS.



Campbell Booth, Applications Director

Dr Campbell Booth is a co-founder of Synaptec Ltd and a Reader at the University of Strathclyde. Campbell has been closely involved in the specification of FITNESS, and will continue to be involved as Applications Lead for Distributed Sensing. He is on the organising committees of the IET DPSP and PACWorld conferences, participates in various CIGRE working groups.



Pawel Niewczas, R&D Director

Dr Pawel Niewczas is co-founder of Synaptec Ltd and leader of the Advanced Sensors Team at the University of Strathclyde. In both roles he focusses on the advancement of optical sensing methods and systems integration in applications that lie predominantly in power and energy sectors. He will be closely involved in FITNESS as joint Technical Lead for Distributed Sensing.



Dr Haiyu Li , Senior Lecturer

Dr Haiyu Li (BSc, MSc, PhD, CEng, MIET, MIEEE) is a Senior Lecturer and an expert of "Power System Automations and Communication Systems" with emphasis on the applied sciences for the development of more flexible, sustainable and intelligent power system automation systems or "Smart Grids" for the future. Dr H Li has led or been involved in many research projects, including: Ofgem NIA National Grid (NG) "AS3 - architecture design and reliability assessment", Currently he is leading Ofgem LCNF Tier 2 "CLASS- customer load active system services and act as academic and chief consultant for project FITNESS.



Prof Vladimir Terzija

Prof. Vladimir Terzija holds an EPSRC Chair in Power System Engineering at The University of Manchester and is a Humboldt Research Fellow. He is the key academic involved in the NIC VISOR and Enhanced Frequency Control Capability (EFCC) projects. He is the convener of Cigré WG B5.14 on "Wide area protection and control technologies" and a member of several other Cigré and IEEE Working Groups and Task Forces. Vladimir will be knowledge dissemination lead for project FITNESS from University of Manchester.



Appendix J: Letters of Support

National Grid



National Grid House
Warwick Technology Park
Gatlowes Hill, Warwick
CV34 6DA

Priyanka Mohapatra
Senior Project Manager
SP Energy Networks Ochil
House
10 Technology Avenue
Hamilton International Technology Park
Blantyre
G72 0HT
Scotland

John Zammit-Haber
Innovation Manager
Electricity Transmission
Asset Management

john.zammit-haber@nationalgrid.com
Direct tel: 01926 654055

www.nationalgrid.com

14 July 2015

Our Reference IT/RD/15_06

Dear Priyanka

Letter of Support in respect of the SP Transmission Plc Network Innovation Competition Proposal - "Future Intelligent Transmission Network Substation (FITNESS)"

Thank you for your request of support for the proposed project entitled "Future Intelligent Transmission Network Substation (FITNESS)".

National Grid understands the challenges faced by Network Licensees in this area, and fully appreciates the benefits from the application of digital technology in substation protection and control systems in achieving vendor interoperability. As you are aware, we have previously collaborated with SP Transmission on the NIA funded project: Architecture of Substation Secondary Systems (AS3) using IEC61850. We understand that it is SPT's intention to use lessons learnt from this project in the FITNESS project and welcome this approach. National Grid is interested in the field experience of the implementation of digital technology, and views the FITNESS project as a potential route to "business as usual" that could bring benefits to all Transmission Owners.

I can confirm that National Grid would like to support this NIC proposal, and as such I am delighted to confirm that Dr Ray Zhang, our Technical Leader, Protection and Control Automation, will be the National Grid representative on the Advisory Board of this project. Ray will provide advice to the development strategy and key deliverables of this project, and will facilitate the dissemination of any outputs and knowledge gained across National Grid, where feasible and appropriate.

Thank you once again, for the opportunity of joining the Advisory Board. We wish you every success and look forward to working with you.

Yours sincerely,

John Zammit-Haber
Innovation Manager

For and on Behalf of
National Grid Electricity plc

National Grid is a trading name for: National Grid
Electricity Transmission plc Registered Office: 1-3
Strand, London WC2N 5EH Registered in England
and Wales. No 2366977

SSE



Priyanka Mohapatra
Senior Project Manager
SP Energy Networks
Ochil House
Blantyre, Glasgow
G72 0HT

Stewart Reid
Head of Future Networks
Inveralmond House
200 Dunkeld Road
PERTH
PH1 3AQ

Our Reference: NIC/NeSTS/180715

Date: 18 July 2015

Dear Priyanka,

Letter of support for Scottish Power Transmission 'FITNESS' project

Thank you for your request of a letter of support for the Scottish Power Transmission FITNESS project. I confirm Scottish Hydro Electric (SHE) Transmission's position of project supporter.

We appreciate the objectives of the FITNESS project and believe that the project could provide benefits to consumers and to the electricity transmission sector. We are willing to support the project through participation on the FITNESS advisory board and are happy to support effective knowledge dissemination by attending events and offering input subject to the agreement of mutually acceptable and appropriate commercial arrangements.

As is the case with SHE Transmission's NeSTS project, we believe that live demonstration projects are an important way of proving innovative ideas so that they may be integrated into 'business as usual' activities. We are interested in the field of innovation for digital substations based on IEC61850-9-2 process bus architecture, especially innovation related to interoperability between multi-vendors and live substation deployment.

We look forward to sharing your experience of FITNESS as you continue to develop this interesting project. Thank you for offering us the opportunity of understanding more about the project – we wish you every success with the NIC bid.

Yours sincerely,

Stewart A Reid
Future Networks and Innovation Manager

For and on behalf of SHE Transmission

Scottish and Southern Energy Power Distribution is a trading name for: SSE Power Distribution Limited Registered in Scotland No. 213489.
SSE Power Distribution Limited Registered in Scotland No. 213489. Scottish Hydro Electric Power Distribution and Distribution in Scotland No. 213490-5/5.
London Registered in Scotland No. 214382. Registered Office: Inveralmond House, 200 Dunkeld Road, Perth, PH1 3AQ. SSE Scottish Energy Power
Distribution and Distribution in England & Wales No. 404202. Registered Office: 10 Victoria Road, Reading, RG1 1BB. Registered in the United Kingdom. Scottish
Energy Networks Limited Registered in Scotland No. 213491.

Z:\0 - Research & Development\NIC Current Projects\NIC 2015\SEN003 NeSTS Stakeholder Engagement\FITNESS Letter of Support SPT.doc



PAC World



To: Priyanka Mohapatra

Senior Project Manager
Scottish Power Energy Networks
Ochil House, 10 Technology Avenue,
Hamilton International Technology Park,
Blantyre, G72 0HT
Scotland

Subject: Letter of Support for NIC Project FITNESS

Dear Priyanka,

This letter is in support of your Network Innovation Competition proposal FITNESS presented at SP Energy Networks Stakeholder Event on 30th of June, 2015 at PAC World Conference Glasgow. I am writing in my capacity as one of the pioneers of IEC61850 standard internationally, including the proposals for function elements based modelling and the original GOOSE message from the UCA 2.

First of all let me congratulate you for your ambition to make GB's pilot fully digital substation a reality. The scope of your project to combine protection automation and control and wide area monitoring and control based on process bus architecture is globally innovative and the outcomes of this project will add valuable lessons learnt to the international standards organisation and especially to IEC61850-9-2 working groups. This project will be an important step towards a low cost, safe and flexible substation design concept fully standardised for enabling SMART grid solutions.

I fully appreciate the fact that standardisation is not business as usual and my advice to all TOs and DNOs will be to undertake demonstration projects like FITNESS to gain the necessary learning experience and understand the concepts before planning digital substations into BaU delivery projects. This step is inevitable as trying to deliver a project based on such innovative concepts without prior demonstration experience may lead to negative financial impact and risks of delays.

My advice to the management of TOs and DNOs and regulatory boards is to appreciate the improved safety aspects associated with digital substations due to the elimination of the hard wired analogue circuits. In case of an open CT circuit utility personnel may be killed, which is a risk that is not acceptable in case when there is a safe alternative based on the communications of sampled values over fiber optic cables. I believe that this has significant legal impact and will lead in the future to a completely change of paradigm for levels of safety at substations and the associated insurance costs.

Lastly, I will like to wish you all success in your endeavours for making this proposal a success and welcome you to join working groups to share experiences of your project with international TOs and DNOs and suppliers who I regularly engage with to make digital substations a success. I personally will like to be in your knowledge dissemination group as a stakeholder and provide my guidance and support during the project delivery if you are successful in your bid for funding.

Kind Regards,

Dr. Alexander Apostolov, IEEE Fellow, CIGRE Distinguished Member
PAC World Editor-in-Chief



ORE Catapult



ORE Catapult
National Renewable Energy Centre
Offshore House, Albert Street, Blyth
Northumberland, NE24 1LZ

T +44 (0)1670 359555
F +44 (0)1670 359666
info@ore.catapult.org.uk

ore.catapult.org.uk
@ORECatapult

SP Energy Network
3rd Floor
Ochil House
10 Technology Avenue
Hamilton International Technology Park
Blantyre
G72 0HT

22th June 2015

Letter of Support for the "FITNESS" proposal

Dear Priyanka,

ORE Catapult are pleased to provide you with this letter of support for your **Future Intelligent Transmission Network Substation (FITNESS)** proposal.

Offshore Renewable Energy Catapult has a mission to drive down the cost of offshore renewable power generation. We appreciate that one of the key barriers in offshore renewable sector is to have a reliable and economical electric connection. Footprint saving, minimise outage, time in delivery and maintenance requirement addressed in the proposal are highly relevant to our cost reduction mission and we believe it would further accelerate the development of the renewable energy power generation industry.

In addition, we believe that the project will further stimulate and enhance technologies for developing onshore live transmission substations, where new sensor technology and advanced data communication standards can be reliably interfaced. Data and experience collected during different stages will be useful to the industry in general and serve as a reference for offshore sector. As one of the drivers in the offshore renewable industry, we would be interested to be included in the knowledge dissemination circle.

We are with great pleasure to provide this letter to support the funding application, and wish every success to the application.

Yours faithfully,

Chong Ng, BEng(Hons), PhD, CEng, MIET
Research and Development Manager, Power Conversion

Offshore Renewable Energy Catapult is a company limited by guarantee, registered in England and Wales with company number 409911.
Registered office: Offshore House, Albert Street, Blyth, Northumberland, NE24 1LZ.



Texas A&M University



TEXAS A&M UNIVERSITY

Department of Electrical and Computer Engineering
Electric Power and Power Electronics Institute
College Station, Texas 77843-3128
TEL (979) 845-7509 FAX (979) 845-9887
kezunov@ecc.tamu.edu

Ms Priyanka Mohapatra
FITNESS Project Coordinator
Scottish Power Energy Networks
Ochil House, Hamilton International Park
Blantyre, G72 OHT

Subject: Letter of support, FITNESS project

Dear Ms Mohapatra,

I am delighted to provide a letter of support for the FITNESS project, which is to be submitted to OFGEM within the Network Innovation Competition.

As the Eugene E. Webb Professor, Director of the Smart Grid Center, as well as the Site Director of NSF I/UCRC "Power Engineering Research Center - Pserc" at Texas A&M University, USA, over the last 30 years I have demonstrated academic leadership in the areas of research and development of microprocessor based power system protection; integration of emerging technology in power system monitoring, protection and control; and the smart grid. One of my particular research streams is the development of future all-digital substations that led to the modern IEC61850 based design, which has resulted in a large number of high impact publications and the delivery of high profile projects to the US power industry.

The FITNESS project offers a number of novel ideas, which will definitely contribute to the Smart Grid agenda in general. I am particularly impressed that the FITNESS project involves the first live trial of a digital substation in the GB power system and the operation of NCITs in parallel with the conventional instrument transformers for comparison. This will generate new experience for the design, commissioning and operation of a live digital substation. I am equally convinced that the project will result in a number of new in-depth questions, which will be of particular value for both academia and the GB power industry.

I look forward to learning from OFGEM about the approval of the FITNESS project and express my direct interest to be involved in the bodies contributing to the project success should the project be selected.

Sincerely yours,

Prof. Mladen Kezunovic, Ph.D., P.E.
Eugene E. Webb Professor
Director, Smart Grid Center



University of Manchester

The University
of Manchester

MANCHESTER
1824

Prof A Brown
Head of School
School of Electrical and
Electronic Engineering
The University of Manchester
Po Box 88
Sackville Street
Manchester M13 9PL

+44(0)161 306 4703
www.manchester.ac.uk

Ms. Priyanka Mohapatra
FITNESS Project Coordinator
Scottish Power Energy Networks
Ochil House
Hamilton International Park
Blantyre
G72 OHT

16 July 2015

Dear Ms Mohapatra,

I was informed from Prof Vladimir Terzija and Dr Haiyu Li that The University of Manchester is acting as the academic partner in the preparation of the NIC FITNESS project proposal.

After learning the specific project details and the list of Work Packages, which I consider as an impressive attempt to contribute to a new modern design of future substations, as well as a more reliable and efficient power system operation, I am delighted to inform you that for the project of this scale The University of Manchester is happy to provide an in-kind FITNESS project support in the scale of **£150k**. This means, that our brand new hardware in the loop facilities (The Manchester Real Time Digital Simulator - RTDS), laboratory space and RTDS technician will be offered for free.

I was particularly pleased to learn from the project proposals that FITNESS is a kind of enablers of the existing NIC projects in which Prof Terzija and colleagues have been also involved (VISOR and SFC)

I wish you a success in your attempts to get the FITNESS project proposal approved from OFGEM and look forward to collaborating with your Consortium.

Yours sincerely

Prof Tony Brown,
Head of School

Prof A Brown, Head of School
School of Electrical and Electronic
Engineering
0161 306 4703
0161 306 4820



EPRI



June 18, 2015

Robin E. Manning
Vice President,
Transmission

Ms. Priyanka Mohapatra
FITNESS Project Coordinator
Scottish Power Energy Networks
Ochil House
Hamilton International Park
Blantyre
G72 OHT

Subject: Support Letter for Scottish Power Energy Network's proposal to the Office of Gas and Electricity Markets (OFGEM)

Dear Ms. Mohapatra,

The Electric Power Research Institute, Inc. ("EPRI") is pleased to offer this letter of support for the Scottish Power Energy Network's proposed OFGEM project, "Future Intelligent Transmission Network Substation (FITNESS). EPRI believes this project is an important next step in addressing the challenge of how to adopt an all-digital smart substations and integration of wide area monitoring, protection and control systems on a widespread basis in the future. The project comes at a critical time for power systems when generation portfolios are radically shifting and wide area monitoring and control of the power system is becoming increasingly critical to secure and efficient grid operation.

EPRI's research efforts are global in scope with over 23% of EPRI's research funding coming from international members. EPRI is familiar with and actively engaged in research activities across Europe through its European membership base and the European presence of its subsidiary, EPRI International Inc. EPRI is a nonprofit corporation organized under the laws of the District of Columbia Nonprofit Corporation Act and recognized as a tax exempt organization under Section 501(c)(3) of the U.S. Internal Revenue Code of 1986, as amended, and seeks involvement in furtherance of its public benefit mission. EPRI conducts research, development and demonstration relating to the generation, delivery and use of electricity for the benefit of the public. Operating as an independent nonprofit organization EPRI brings together scientists and engineers as well as experts from academia and industry to help address challenges in electricity. EPRI is excited about the proposed OFGEM project because it may lead to safer substations, more secure supply of power and faster responses to unscheduled outages.

The advent of non-conventional instrument transformers and all-digital communications between protection and control devices within substations has opened opportunities to make substations safer and render protection and control devices more resilient, intelligent, secure and reliable. Many expect such substations to have smaller footprints, reduced electrical design requirements, faster commissioning times, more flexible device configurability and simpler future upgrade paths. While all-digital substations are becoming a global trend, there are practical challenges to their successful implementation that need to be addressed; in particular, the design, commissioning and operation of multi-vendor IEC61850 compliant devices.

Together ... Shaping the Future of Electricity

CHARLOTTE OFFICE
1300 West W.T. Harris Boulevard, Charlotte, NC 28262-8550 USA • 704.595.2000 • Fax 704.595.2860
Customer Service 800.313.3774 • www.epri.com



RE: Support Letter for Scottish Power Energy Networks; EPRI DKT 150369
June 18, 2015
Page 2

The FITNESS project is comprehensive in scope and aims to tackle these challenges while setting the standard for future all-digital substation projects. The project has the capability of serving as a leading example of smart grid development and integration of new technologies from the measurement devices in the substation to the situational awareness and on-line analysis systems in the control center. Progress in this area is important to resolving current and future limitations to the growth of renewables, smart grids and other devices.

This project is particularly important to the entire international smart grid development since it is directly concerned with the impacts of actual technology implementations across a wide geographical area as well as theoretical approaches. The results are anticipated to be valuable in assessing the performance and the application issues associated with these technologies so that they can be deployed elsewhere around the world with confidence.

Through our engagements with Scottish Power Energy Networks in the UK, National Grid in the UK, EirGrid in Ireland and Terna in Italy in particular, we have seen the issues associated with high wind and solar penetration, challenges to modernize substations and the urgent need for solutions to support system operators at the forefront of the all-digital substation transition.

EPRI looks forward to coordinating with the FITNESS project team and providing support for the project where warranted. The learning and knowledge generated from this coordination will be of great value to the international community. EPRI's key objective is to make electricity safe, reliable, affordable, and environmentally responsible for society through collaboration, thought leadership, and scientific and technological innovation. The proposed FITNESS project directly relates to EPRI programmatic research areas including Renewable Integration, Grid Operations and Planning, and Information and Communications Technologies (ICT) and Substations.

EPRI does not endorse specific facilities, companies or products, programs or projects or allow any of its work to be used for lobbying, campaigning or political activities. This letter of support does not offer financial and/or cost share support. For the avoidance of doubt, this letter may not be construed by the proposers of the project, EPRI or any third party as creating any legally binding obligation.

EPRI has a long history of participating in many domestic and international collaboration activities with the utility industry, as well as with government organizations. We support the work that the FITNESS project intends to undertake. EPRI is directionally supportive of the effort within the electric power industry where the proposed OFGEM project seeks to help advance the needs of the electric power sector which may indirectly benefit the public through achieving EPRI's overall goal of advancing knowledge in this area. EPRI would look forward to exploring opportunities for further collaboration with the FITNESS team in this effort for the benefit of stakeholders, our customers, and society at large.

Yours truly,

Rob Manning
Vice President, Transmission
Electric Power Research Institute
1300 W.T. Harris Blvd. | Charlotte, NC 28262 Tel:
704.595.2716 | Mobile: 423.619.3963 Email:
rmanning@epri.com



RED Electrica



13th July 2015

Ms. Priyanka Mohapatra
FITNESS Project Coordinator
Scottish Power Energy Networks
Ochil House
Hamilton International Park
Blantyre
G72 0HT

Subject: Letter of support for SP Energy Networks FITNESS project

Dear Ms. Mohapatra,

As Head of R&D and EU projects department within Red Eléctrica, I confirm Red Eléctrica is very interested to learn of the live trial of a complete IEC 61850 compliant substation in the GB transmission system that you have proposed in the Future Intelligent Transmission Network SubStation (FITNESS) project and, after discussion within the company, we would like to offer our support for this innovation project. Furthermore, we would be happy to be involved as a stakeholder and to provide our insights in to the project progress and outcomes wherever possible.

In our role the Spanish Transmission System Operator, we do believe that live trials of this nature are essential for proving the interoperability and reliability of IEC 61850 hardware and for developing suitable operating practices to exploit their benefits. The benefits of the future substation to be trialled in FITNESS (e.g. plug and play of protection and control, and the improved measurement performance of non-conventional instrument transformers) will help to deliver the improved monitoring and flexibility of power systems that is necessary for the cost effective deployment of higher penetrations of renewable generation. The percentage of demand supplied by renewable generation was around 25% in Spain in 2014 and this figure rises almost to 70% at certain moments, which will bring with it new challenges for protection and control. As an islanded power system GB will face many of these challenges before the European interconnection and ambitious, innovation projects like FITNESS will serve to guide the development of substations that are compatible with the needs of the future power system not only in GB and Europe but the World.

Yours sincerely,

Vicente J. González
Head of R&D and EU projects department

P^o del Conde de los Gaitanes, 177
28109 Alcobendas - Madrid

Tel: 91 650 85 00 / 20 12
Fax: 91 650 45 42 / 76 77
www.ree.es

RED ELÉCTRICA DE ESPAÑA S.A.U. C.I.F. A-8339219
REGISTRO MERCANTIL DE MADRID: T040 21097
FOLIO 191 - SECCIÓN 8 - HOJA 14162021



ABB



Our ref: Z15033S

Date: 20th July 2015

To whom it may concern,

20 July 2015

This letter is to confirm ABB's support of SP Energy Networks in this innovation project.

The FITNESS project will demonstrate ABB's latest Substation Automation solutions and innovation through the unique deployment of this technology in an end to end Digital Substation scheme, this will be a first in the UK.

Furthermore, this is one of only a few Digital Substation projects globally that will see a multi-vendor implementation of process bus technology in a live substation from protection device to primary equipment.

The proposed solution will also demonstrate the integration of ABB's Phasor Measurement technology with WAMS networks, the output of which will improve interoperability and quality of information between the digital substation and wide area network.

The output of this project is expected to deliver significant savings in future substation refurbishment and replacement projects which will not only become "business as usual" for SP Energy Networks but will help to define the best practice approach for all future Digital Substation projects throughout the UK Transmission & Distribution Network. As a leader in this field globally, this is an exciting prospect for ABB.

Yours sincerely,

Andy Osiecki

Director

Network Management

ABB Limited

ABB Limited

ABB Limited
Riverside Way
Weybridge, Surrey
Middlesex TW20 2ET
United Kingdom
Tel: +44 (0)181 606 1000
Fax: +44 (0)181 606 1001
www.abb.com

GRID
SYSTEMS

ALSTOM

St Leonards Avenue
Stafford ST17 4LX UK
Phone: +44 (0) 1785 232251
Fax: +44 (0) 1785 786426
www.alstom.com

Priyanka Mohapatra
Senior Project Manager
SP Energy Networks
Ochil House, 10 Technology Avenue
Hamilton International Technology Park
Blantyre, G72 0HT, Scotland UK

17 July 2015

Re: Letter of Support in respect of the SP Transmission Ltd Network Innovation Competition proposal
"Future Intelligent Transmission Network Substation (FITNESS)"

Dear Priyanka,

We are delighted to confirm our support of SP Transmission's proposal for the FITNESS project for funding under Ofgem's Network Innovation Competition programme. We believe that this project, if approved, will be a landmark for the adoption of the Digital Substation as a business-as-usual solution in the GB network, and we would like to thank you for your invitation to participate in it. To our knowledge, this is a globally innovative project because of its ambition to address the full functionality of substation instrumentation based on the IEC 61850 set of standards, incorporating novel measurement techniques and including monitoring, protection and wide area control functions, in a live substation.

We have strongly supported the technology change to IEC 61850 standards, including the Process Bus, and the solutions that are enabled by it. We are committed to delivering a fully integrated solution suite within the substation, and addressing the wider requirements of information and control that are emerging with the move towards a low carbon economy. We have worked extensively in wide area monitoring and control technologies, and recognise that integration of monitoring and control functions is an important consideration for the requirements for substation design, and we are pleased to see this aspect emphasised in the FITNESS project.

From the perspective of global experience in the Digital Substation and related technologies, we are aware that there is a significant challenge facing transmission licensees adopting new technology in this area. Replacing traditional hardwired solutions with digital communications implies a change in practices and a need to build up a body of practical experience. We therefore support the approach adopted by SP Transmission to introduce the new technology with a measured approach to risk through parallel live operation of conventional and non-conventional solutions. Combining this valuable practical

ALSTOM Grid UK Limited
Registered Office: St Leonards Avenue, Stafford ST17 4LX
Registered in England and Wales: 04855843

experience with a focus on knowledge dissemination within SP Transmission and with other stakeholders should build the confidence to adopt the design approach as a business-as-usual practice.

We are pleased that the project will demonstrate interoperability, and look forward to participating in the collaboration, and to work together to deliver the experience with interoperability that is needed. We recognise that interoperability is crucial to the rollout of the FITNESS technology.

We believe that FITNESS is a very valuable project that will open the way for substantial cost and environmental benefits in the design and operation of the transmission network, with potential for further benefits in the distribution network.

Yours sincerely,



Mr Neil Beardsmore
MD Commercial Solutions North Europe
Alstom Grid UK Ltd

Rte

Réseau de transport d'électricité

VOS REF

NOS REF LE-RD-DR&DI-DP-2015-00131

INTERLOCUTEUR Thierry Buhagiar

TÉLÉPHONE 06 18 96 19 19

E-MAIL Thierry.buhagiar@rte-france.com

OBJET FITNESS support letter

Ms Priyanka Mohapatra
 Scottish Power Energy Networks
 Ochil House, 10 Technology Avenue
 Blantyre, G72 0HT
 Scotland

La Défense, 23/07/2015

Dear Ms Priyanka Mohapatra,

As part of the French government plan Investment for the Future, RTE decided to experiment a new substation automation concept based on the latest edition of the IEC 61850 standard. The Research and Development project Smart Substation was launched at the end of the year 2012 in order to bring new answers to the challenges arising from emerging renewable energy sources integration in the context of the European energy policy.

SP Energy Networks approached us in Feb/2015 with the concept of project FITNESS, which is complementary to our project and will build on the learnings to implement pilot digital substation in GB and include innovative multi-vendor interoperability, Wide Area Monitoring and Control and Substation to System to integration into this architecture.

RTE has the strong conviction that the Smart Substation solution can help the TSO to adapt the existing model to the new paradigm in an economical manner by giving more agility, flexibility, controllability, and situational awareness. Our objective in France is to include twelve conventional substations and 500 km OHL in the program. On this extended perimeter, the Smart Substation solution will improve the resilience and give additional capacities for more than 1000 MW of wind farms installed capacities, 600 MW of energy consumption and 900 MW of power transformers capacities (225 or 400 kV/90kV) with only one Smart Substation. We can foresee FITNESS after its successful demonstration can achieve similar goals in the GB.

We will be pleased to participate in project FITNESS as a Project Advisor to share our approach and help to build a common vision among the European TSO in order to give clear signals to the

major suppliers as previously requested by the ENTSOE board to accelerate the emergence of tomorrow's technologies.

We look forward to working closely with you on these important issues in the months and years ahead.

Sebastian Henry
 Research and Development Director

Appendix K: Glossary of Terms

| | |
|------------------|--|
| ACAM | Angle Constraint Angle Management |
| AS3 | Architecture of Substation Secondary Systems |
| CAPEX | Capital Expenditure |
| CBA | Cost Benefit Analysis |
| CBC | Circuit Breaker Control |
| CIM | Common Information Model |
| COMTRADE | Common format for Transient Data Exchange |
| CT | Current Transformer |
| DECC | Department of Energy and Climate Change |
| DNO | Distribution Network Owner |
| EFCC | Enhanced Frequency Control Capability |
| EMS | Energy Management System |
| ENS | Energy Not Supplied |
| ETYS | Electricity Ten Year Statement |
| FD | Fully Digital |
| FES | Future Energy Scenarios |
| FITNESS | Future Intelligent Transmission Network Substation |
| GG | Gone Green |
| GOOSE | Generic Object Orientated Substation Event |
| HV | High Voltage |
| IEC | International Electrotechnical Commission |
| IED | Intelligent Electronic Device |
| IEEE | Institute of Electrical and Electronics Engineers |
| IPR | Intellectual Property Rights |
| ISP | Initial Screening Proposal |
| LAN | Local Area Network |
| LCL | Low Carbon Life |
| LV | Low Voltage |
| MBSS | Monthly Balancing Services Summary |
| MU | Merging Unit |
| NCIT | Non-conventional Instrument Transformer |
| NCVT | Non-conventional Voltage Transformer |
| NETS SQSS | National Electricity Transmission System Security and Quality of Supply Standard |
| NGET | National Grid Electricity Transmission |

| | |
|---------------|--|
| NIA | Network Innovation Allowance |
| NIC | Network Innovation Competition |
| OFTO | Offshore Transmission Owner |
| OPEX | Operational Expenditure |
| PC | Phasor Controller |
| PDT | Project Delivery Teams |
| PMU | Phasor Measurement Unit |
| PQ | Power Quality |
| PU | Partial Uptake |
| RA | Regional Aggregator |
| RIIO | Revenue = Incentives + Innovation + Outputs |
| ROCOF | Rate of Change of Frequency |
| RTE | Reseau de Transport d'Electricite |
| SAS | Substation Automation System |
| SCADA | Supervisory Control And Data Acquisition |
| SCS | Substation Control System |
| SCU | Switchgear Control Unit |
| SFC | SMART Frequency Control – see Enhanced Frequency Control Capability (EFCC) |
| SME | Small to Medium Enterprise |
| SO | System Operator |
| SOF | System Operability Framework |
| SP | Slow Progression |
| SPEN | Scottish Power Energy Networks |
| SPT | Scottish Power Transmission |
| SSE | Scottish and Southern Energy |
| SV | Sampled Values |
| TO | Transmission Owner |
| TRL | Technology Readiness Level |
| UoM | University of Manchester |
| VISOR | Visualisation of Real Time System Dynamics using Enhanced Monitoring |
| VT | Voltage Transformer |
| WAC | Wide Area Control |
| WAMPAC | Wide Area Monitoring, Protection and Control |
| WAMS | Wide Area Management System |
| WMU | Waveform Monitoring Unit |

Addendum: Revisions made in resubmission

This section documents and explains the modifications that have been made to the submission following the discussions with the Expert Panel and the Q&A process.

1.1. Summary of changes

The following modifications have been made in the resubmission:

Expert Panel's Big Question:

- Reduction of University of Manchester costs of £118k, thereby reducing the overall project cost of the same order, in response to the Expert Panel's Big Question.

Discussions with Expert Panel and consultants at bilateral meetings:

- Inclusion of incremental benefits to supplement the benefit assessment,
- Clarification of the roles of the University of Manchester and Synaptec within the project

Correcting typing errors:

- SDRC dates

The above revisions are reflected in the revised financial spreadsheet.

1.2. Explanation of changes

Reduction in University of Manchester cost

The Expert Panel requested further explanation and of the costs allocated for Research Associate (RA). UoM confirm that the RA costs are in line with Expert Panel's expectations of £100k for 12 months, with a total of 36 months' involvement. The additional £118k associated with RA costs covered additional the supervision costs for RAs. These supervision costs has been mistakenly double counted in the costs associated with Prof. Terzija's and Dr. Li's involvement. The revised costs therefore remove the duplicated supervision costs of £118k.

This reduction is now reflected in the work streams involving RAs from UoM in project FITNESS. The overall project cost is now reduced from £11117k to £10998k and the NIC funding request is reduced from £8442k to £8335k.

Incremental benefits

The Q&A process and discussions from 1st bilateral meeting highlighted the necessity to distinguish between the benefits that only accrue to the demonstration project in comparison to what may otherwise appear as business as usual.

The FITNESS team confirmed that technological advancement and the emerging needs of standardisation and flexibility will eventually drive the adopting of digital substations, however, without a co-ordinated and collaborative demonstration project such as FITNESS, the adoption of digital substations will be delayed with a slower uptake and heavily dependent on learnings from international experience. Furthermore, timely contribution of GB TO experience into development of international substation standards will be negatively affected.

It was crucial to identify the incremental benefits delivered by project FITNESS. Additional CBA analysis was undertaken for to explore the business case for digital substations without FITNESS. The benefits were thus calculated assuming a delayed adoption of digital substations by 8 years and thus delaying the digital to digital replacement scenario by further 8 years. It was also assumed that without a demonstration project and only based on knowledge gathered from international experience the uptake of digital substations will initially (period of 10 years) by reduced by 25 years.

The CBAs for digital substation benefits to GB TOs and customers with and without FITNESS provided a clear comparison of the financial benefit values between both roadmaps for the same benefit cases (substation costs, constraint payments, operation and maintenance costs and carbon benefits). The benefits were then compared and the difference between both CBAs was documented as incremental benefits in the re-submission. Details of incremental benefits are documented in Appendix B.

Roles of University of Manchester and Synaptec

Further clarification has been provided to explain the roles of the partners as following feedback during the discussions with the Expert Panel.

Synaptec is working on existing NIA project and it was unclear whether work will be repeated in this NIC project. The resubmission clarifies that Synaptec will be developing sensors as a part of the NIA project and, in FITNESS, these sensors will be demonstrated to be IEC61850-9-2 compatible proving the concept that standardisation allows for multi-vendor equipment not only from any vendor to be connected seamlessly. Synaptec will also demonstrate the monitoring capability of their sensor for the first time as part of FITNESS.

The question was raised in the bilateral discussions regarding the continued use of UoM lab setup for testing digital substation architecture following the project FITNESS by other TOs, DNOs, OFTOs for business-as-usual deployment. UoM clarified that this setup will be available to other network owners for testing at a discounted rate.

Corrections of typing errors

Minor corrections have been made to some of the SDRC dates which were erroneously stated in the original submission.